

59-MOMENTEN
MOMENT
61-ÜBERLAST
OVERLOAD
102-110%

60-KONSTANTE
CONSTANT
61-ÜBERLAST
OVERLOAD
62-GANG 1
GEAR
102-110%

61-ÜBERLAST
OVERLOAD
62-GANG 2
GEAR

61-ÜBERLAST
OVERLOAD
62-GANG 3
GEAR

53-VORABSCHALTUNG
SPEED REDUCTION
59-MOMENTEN
MOMENT
61-ÜBERLAST 90-97%
OVERLOAD

61-ÜBERLAST
OVERLOAD
63-SCHNELLGANG
HIGH SPEED
62-GANG 1
GEAR

61-ÜBERLAST
OVERLOAD
63-SCHNELLGANG
HIGH SPEED
62-GANG 2
GEAR

3			Gez.	31.08.09		Maßstab	LIEBHERR-WERK	61-ÜBERLAST OVERLOAD	TYPE	EC-H	=	S2	
2			Bearb.	17.03.93	ELLINGER	:	BIBERACH GmbH		Zeich-Nr.	4005-21532	+	Blatt	2+
1	Änderung	Datum	Name	Datum	Name		Copyright (c)					Ident Nr.	

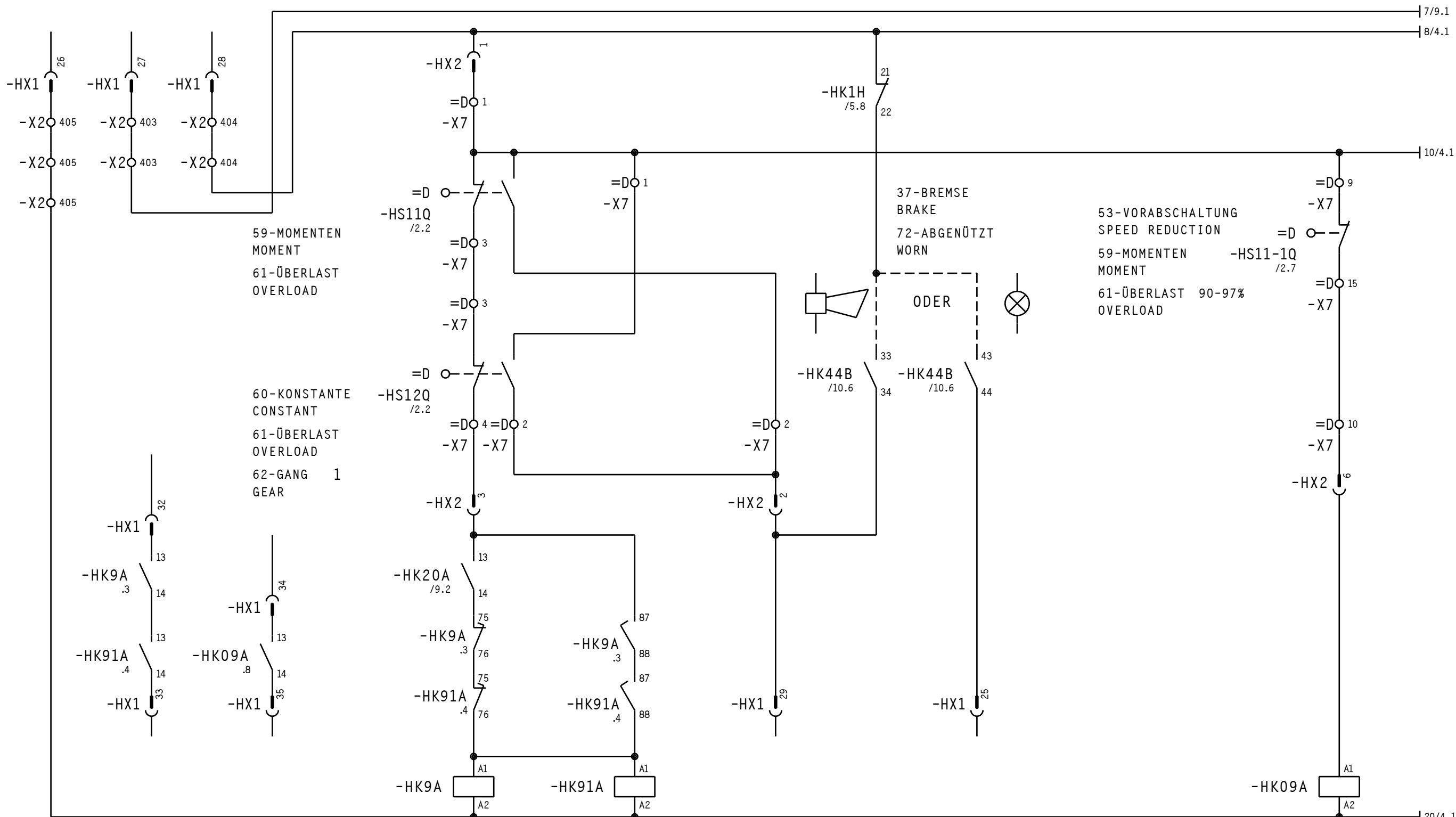

59-MOMENTEN
MOMENT
61-ÜBERLAST
OVERLOAD

60-KONSTANTE
CONSTANT
61-ÜBERLAST
OVERLOAD
62-GANG 1
GEAR

37-BREMSE
BRAKE
72-ABGENÜTZT
WORN

53-VORABSCHALTUNG
SPEED REDUCTION
59-MOMENTEN
MOMENT
61-ÜBERLAST
OVERLOAD

-HS11-1Q
/2.7

61-ÜBERLAST
OVERLOAD

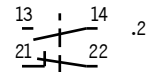
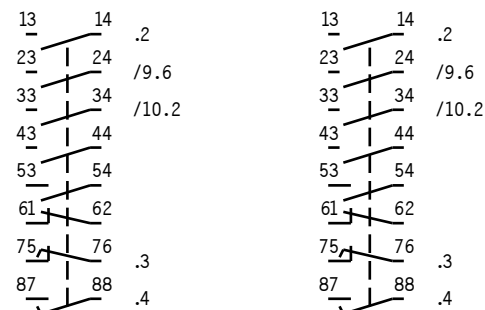

3			Gez.	31.08.09		Maßstab	LIEBHERR-WERK	61-ÜBERLAST OVERLOAD	TYPE	EC-H	=	S2	
2			Bearb.	17.03.93	ELLINGER	:	BIBERACH GmbH		Zeich-Nr.	4005-21532	+	Blatt	3+
1	Änderung	Datum	Name	Datum	Name		Copyright (c)					Ident Nr.	

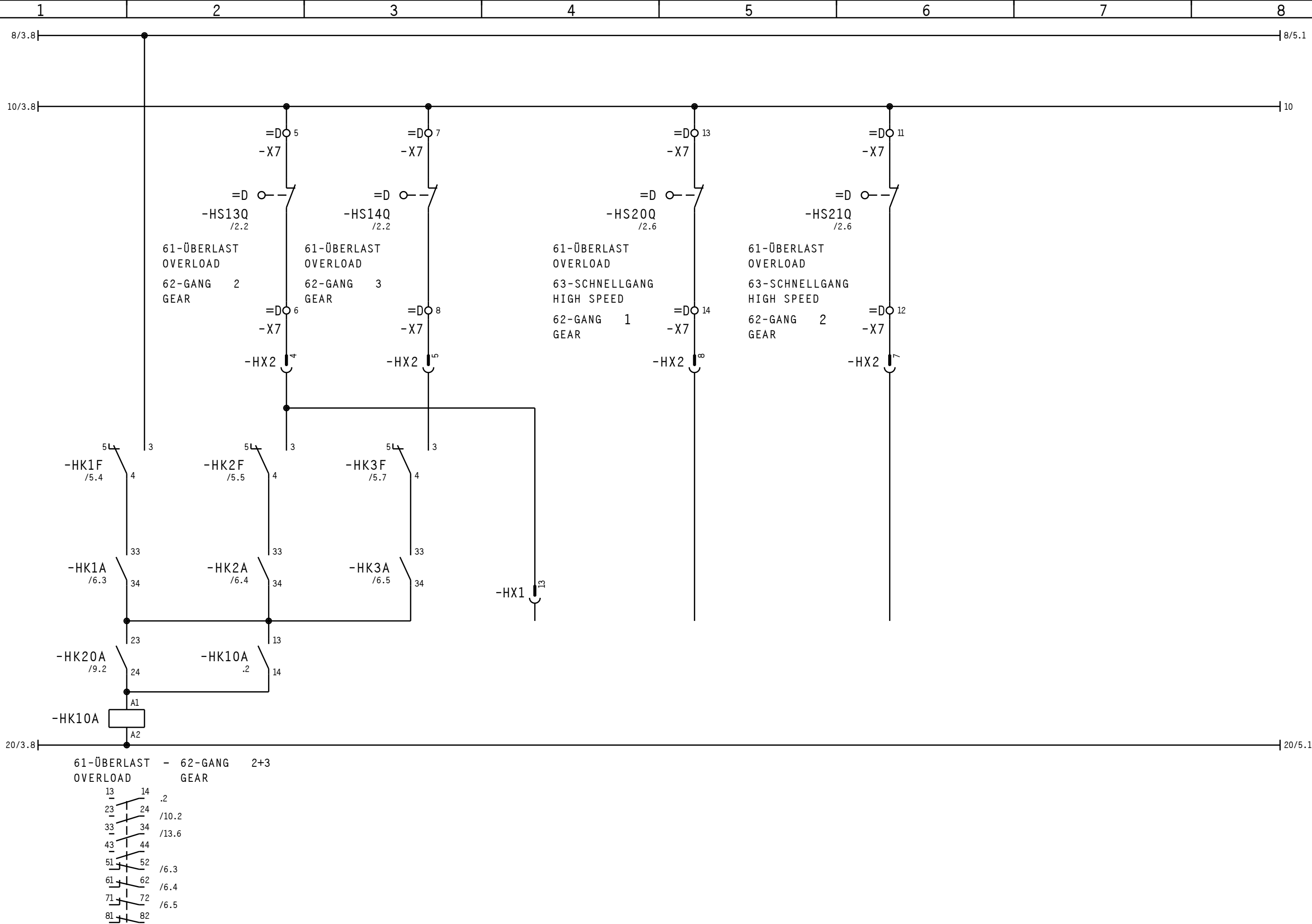

3			Gez.	31.08.09		Maßstab	LIEBHERR-WERK	61-ÜBERLAST OVERLOAD	TYPE	EC-H	=	S2
2			Bearb.	17.03.93	ELLINGER	:	BIBERACH GmbH		Zeich-Nr.	4005-21532	+	Blatt
1	963000	09.01.96	Änderung	Datum	Name	Datum	Name	Copyright (c)			Ident Nr.	

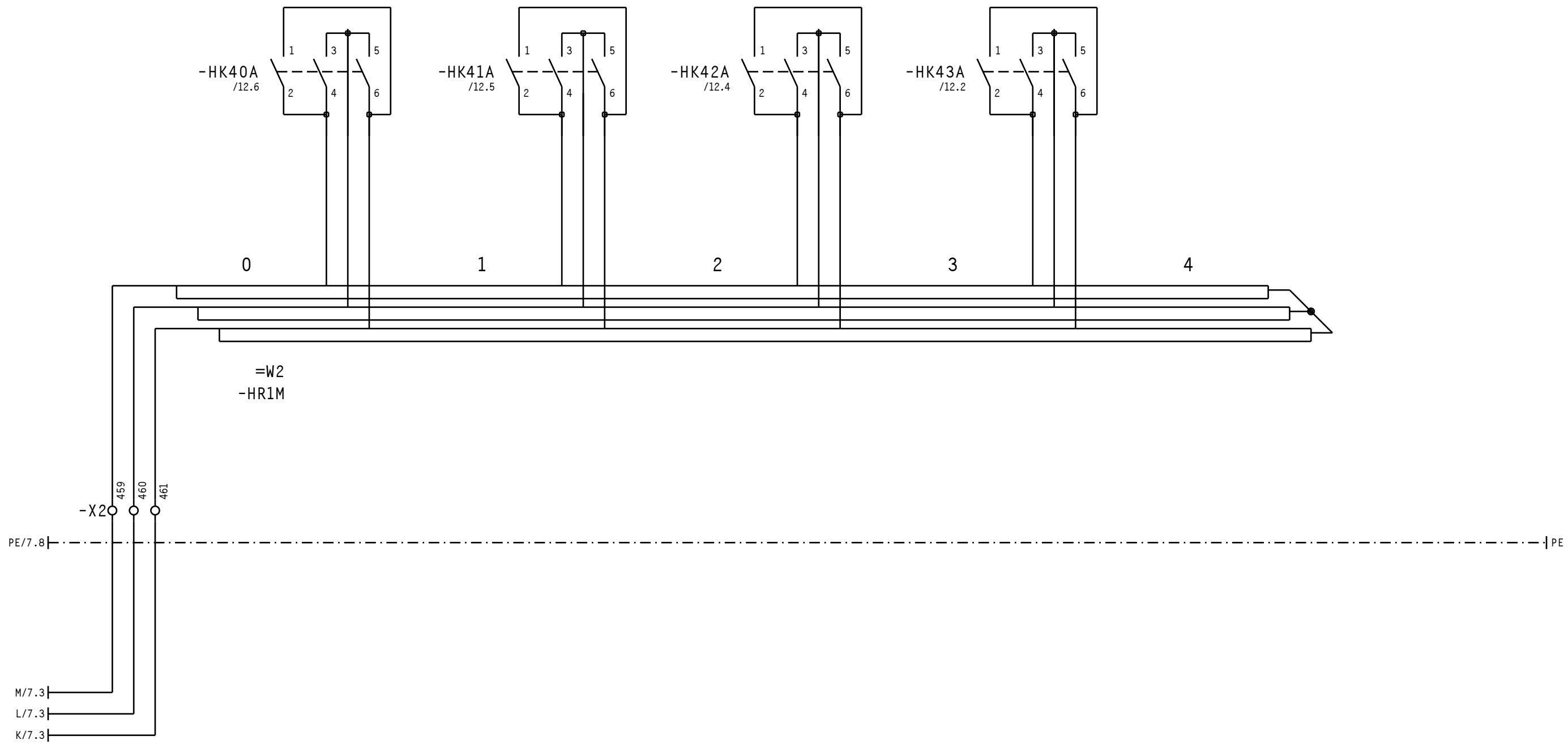

3			Gez.	31.08.09		Maßstab	LIEBHERR-WERK	30-HUBWERK HOIST GEAR	TYPE	EC-H	=	S2
2			Bearb.	17.03.93	ELLINGER	:	BIBERACH GmbH		Zeich-Nr.	4005-21532	+	
1	Änderung	Datum	Name	Datum	Name		Copyright (c)				Blatt	8+

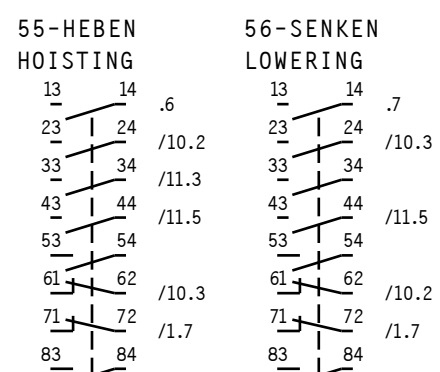
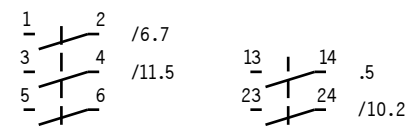
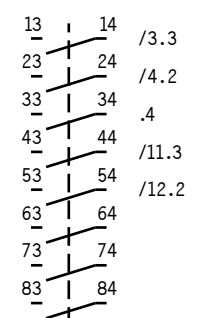
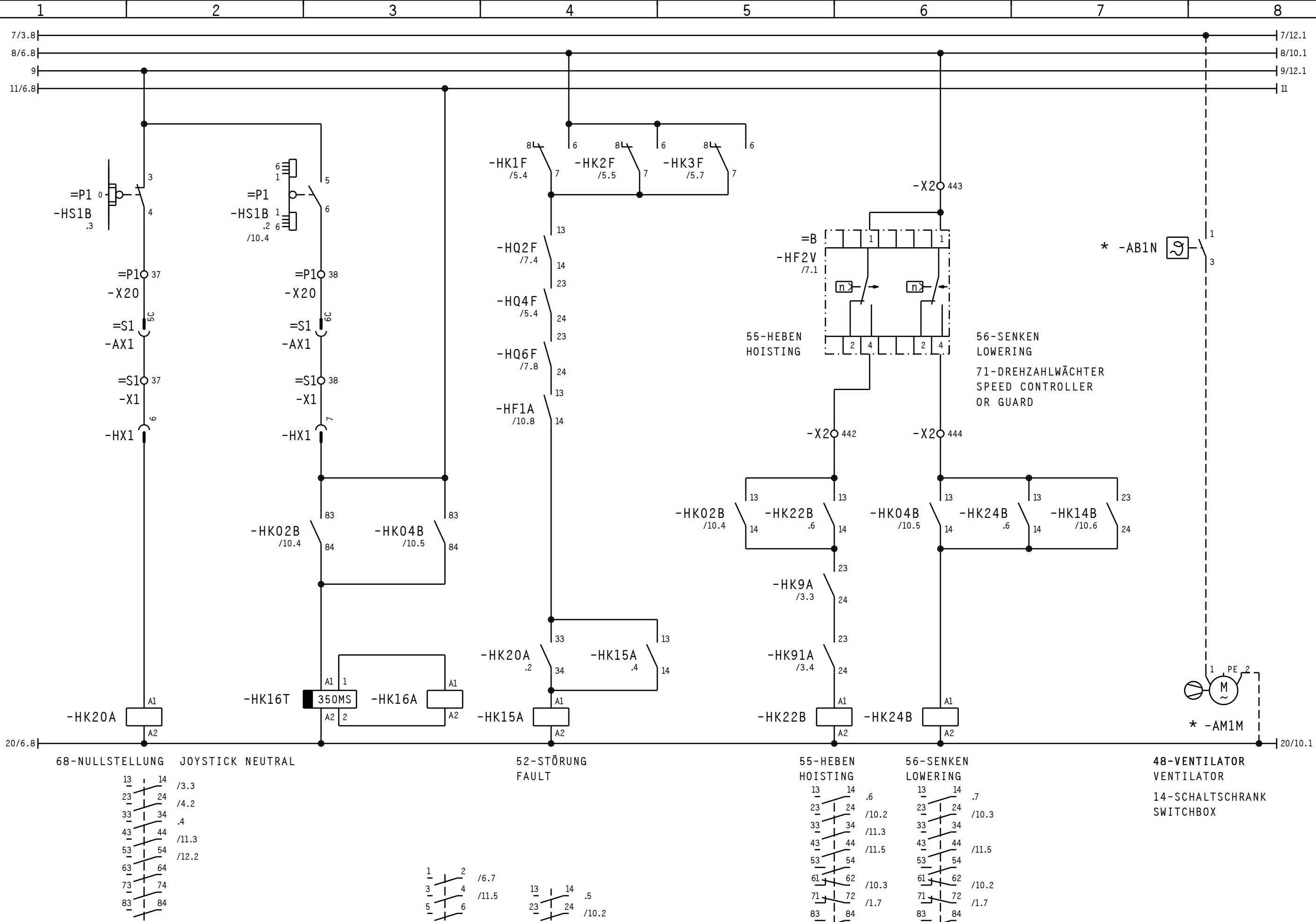

3			Gez.	31.08.09		Maßstab	LIEBHERR-WERK	30-HUBWERK HOIST GEAR	TYPE	EC-H	=	S2	
2			Bearb.	17.03.93	ELLINGER	:	BIBERACH GmbH		Zeich-Nr.	4005-21532	+	Blatt	9+
1	Änderung	Datum	Name	Datum	Name		Copyright (c)					Ident Nr.	

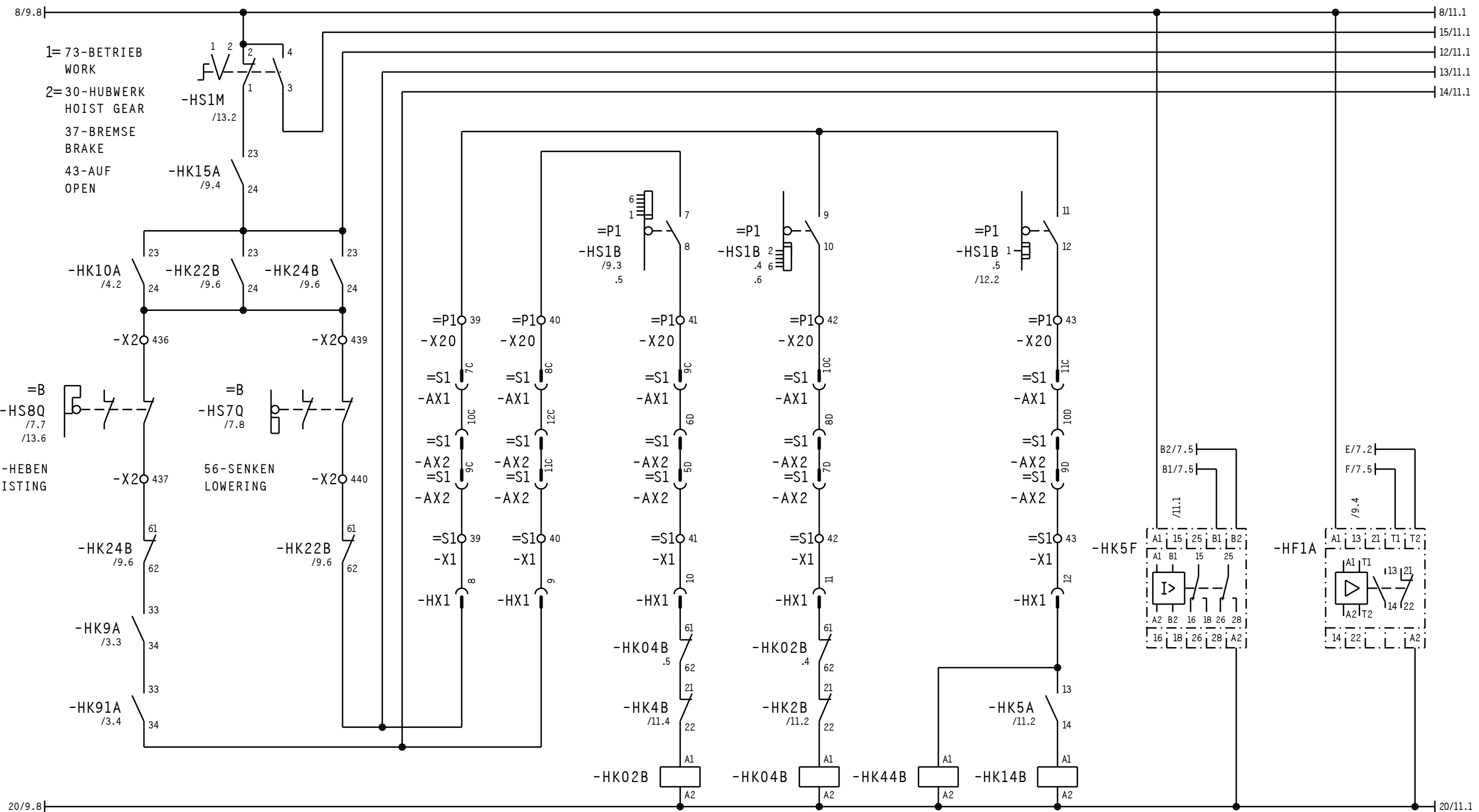

1= 73-BETRIEB
WORK
2= 30-HUBWERK
HOIST GEAR
37-BREMSE
BRAKE
43-AUF
OPEN

=B
-HS8Q
/7.7
/13.6
55-HEBEN
HOISTING

=B
-HS7Q
/7.8
56-SENKEN
LOWERING

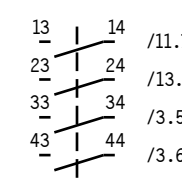
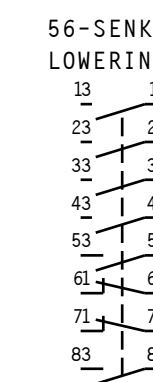
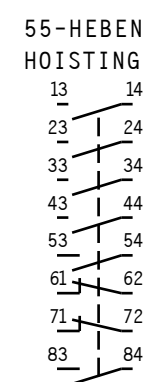

3			Gez.	31.08.09		Maßstab	LIEBHERR-WERK	30-HUBWERK HOIST GEAR	TYPE	EC-H	=	S2	
2			Bearb.	17.03.93	ELLINGER	:	BIBERACH GmbH		Zeich-Nr.	4005-21532	+	Blatt	10+
1	Änderung	Datum	Name	Datum	Name		Copyright (c)					Ident Nr.	

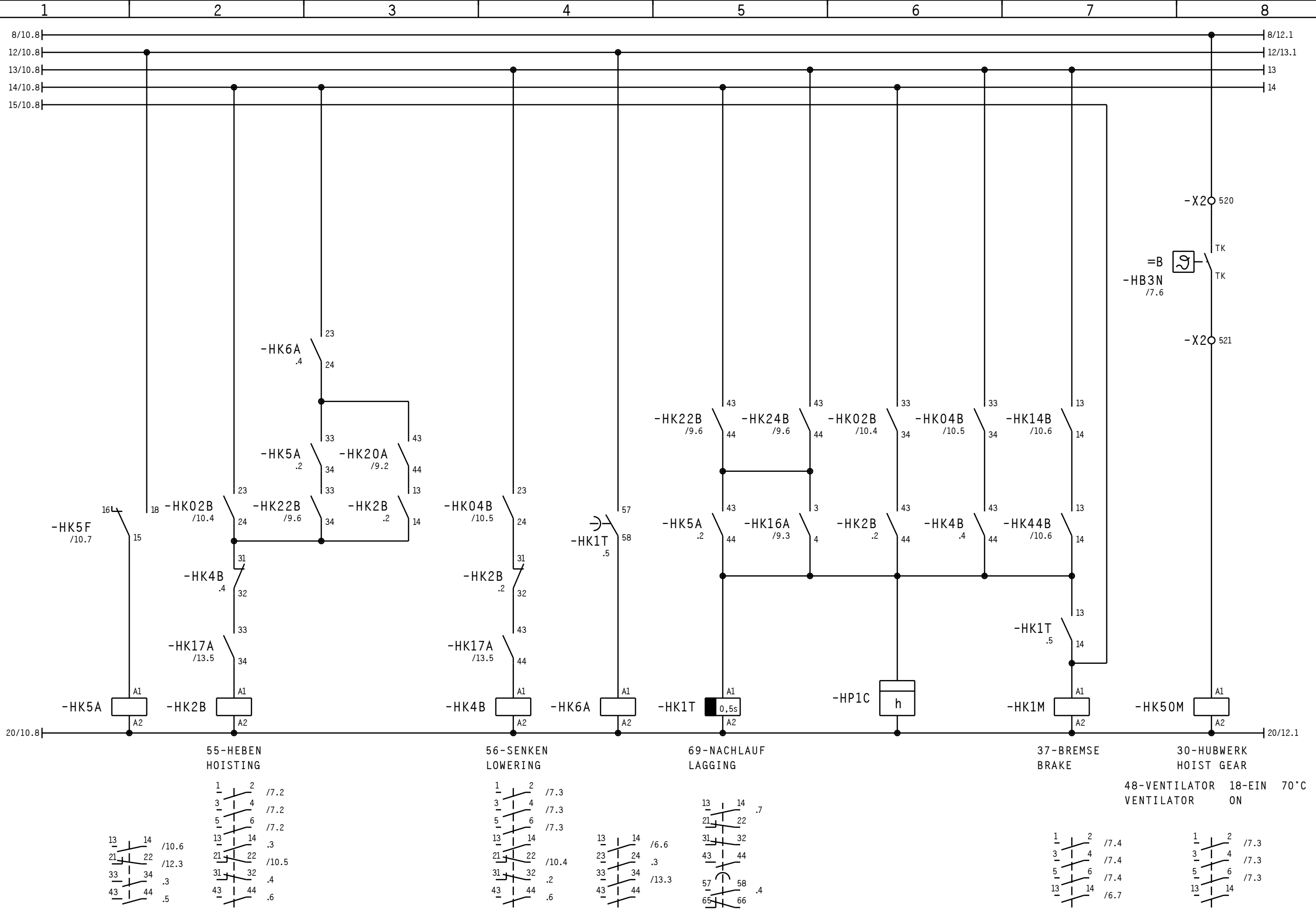

3			Gez.	31.08.09		Maßstab	LIEBHERR-WERK	30-HUBWERK HOIST GEAR	TYPE	EC-H	=	S2	
2			Bearb.	17.03.93	ELLINGER	:	BIBERACH GmbH		Zeich-Nr.	4005-21532	+	Blatt	11+
1	Änderung	Datum	Name	Datum	Name		Copyright (c)					Ident Nr.	

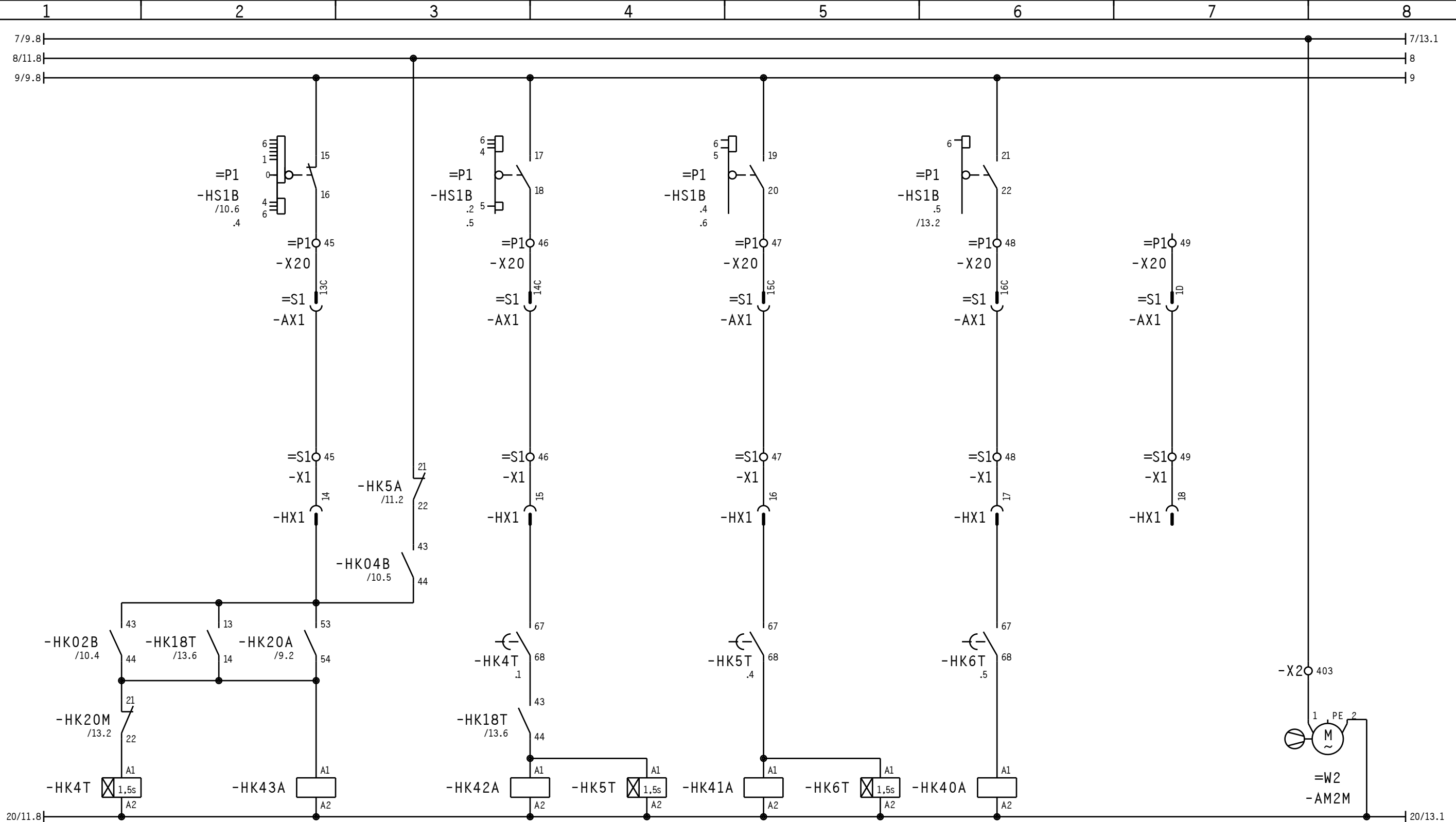

48-VENTILATOR
 VENTILATOR
 32-WIDERSTANDSSCHRANK
 RESISTOR BOX

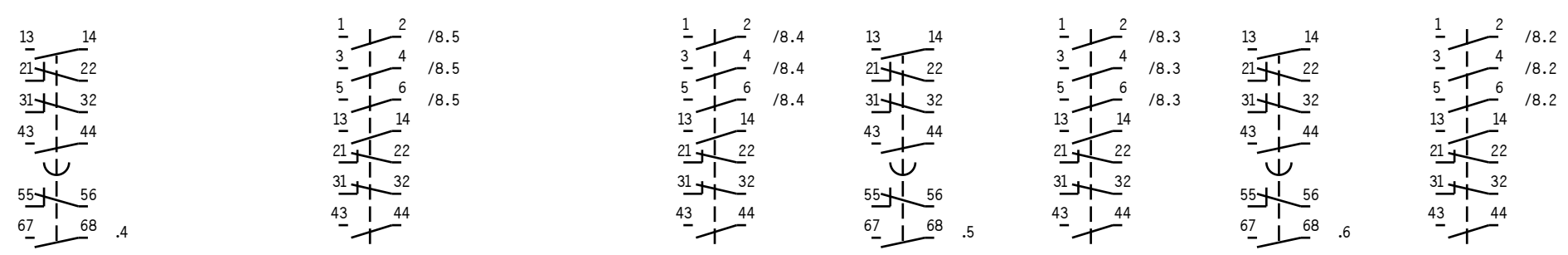

3			Gez.	31.08.09		Maßstab	LIEBHERR-WERK	30-HUBWERK HOIST GEAR	TYPE	EC-H	=	S2	
2			Bearb.	17.03.93	ELLINGER	:	BIBERACH GmbH		Zeich-Nr.	4005-21532	+	Blatt	12+
1	Änderung	Datum	Name	Datum	Name		Copyright (c)					Ident Nr.	

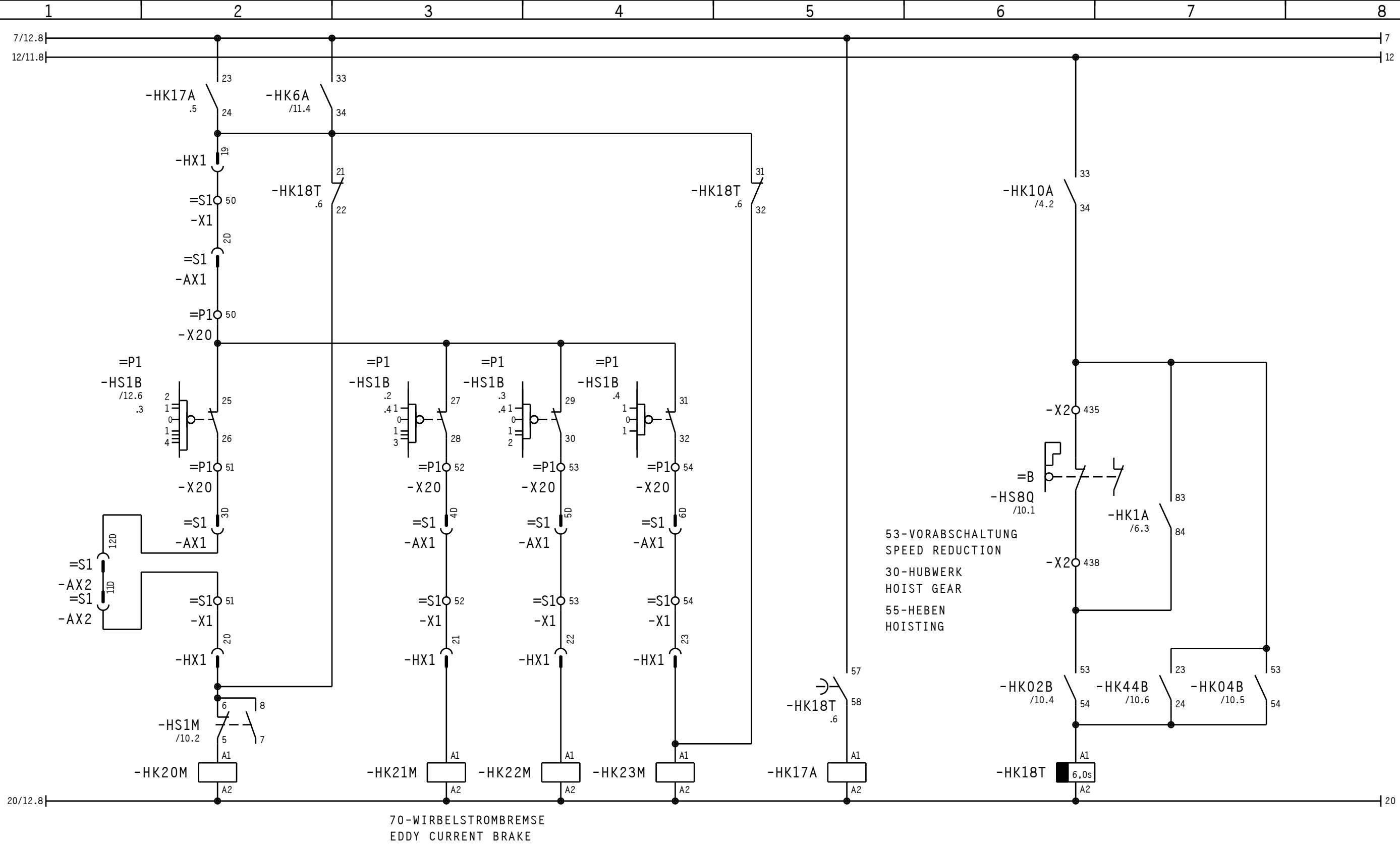

53-VORABSCHALTUNG
SPEED REDUCTION
30-HUBWERK
HOIST GEAR
55-HEBEN
HOISTING

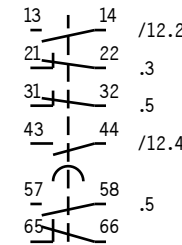
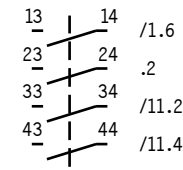
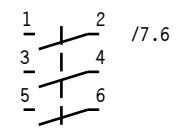
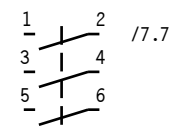
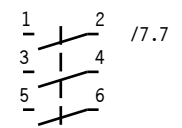
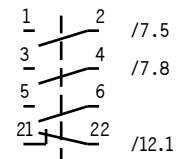

3			Gez.	31.08.09		Maßstab	LIEBHERR-WERK	30-HUBWERK HOIST GEAR	TYPE	EC-H	=	S2	
2			Bearb.	17.03.93	ELLINGER	:	BIBERACH GmbH		Zeich-Nr.	4005-21532	+	Blatt	13-
1	933127	16.07.93	Änderung	Datum	Name	Datum	Name		Copyright (c)			Ident Nr.	