

Gegenausleger komplett **F**

Counter-jib complete

Contre-flèche complète

	Seite
Gegenausleger Counterjib Contre-flèche	F 1
Gegenausleger-Abspannung Counterjib suspension Haubanage de contre-flèche	F 3
E-Installation Gegenausleger Electric installation counterjib Installation électrique contre-flèche	F 4
Getrieberahmen Gear frame Cadre de mécanisme	F 6
Hubwerk WiW 260 JX 421 Hoisting unit Treuil de levage	F 9
Getriebe Get 320 JX 412 Transmission Engrenage	F 12
Welle 1 komplett Shaft 1 cpl. Arbre 1 cpl.	F 16
Welle 2 komplett Shaft 2 cpl. Arbre 2 cpl.	F 18
Getriebe Get 1250 MW 421 Transmission Engrenage	F 21
Welle 3 komplett Shaft 3 cpl. Arbre 3 cpl.	F 25

	Seite
Seiltrommel komplett Rope drum cpl. Tambour de câble	F 27
Bremse Brake Frein	F 29
Bremszange Brake clamp Pince-freinage	F 31
Bremszylinder komplett Brake cylinder cpl. Cylindre de frein cpl.	F 33
Hydraulikaggregat Hydraulic aggregate Groupe hydraulique	F 34
Spindelendschalter Rotating limit switch Interrupteur de fin de course de tige	F 37
E-Motor (Hubwerk) Electric motor (hoist gear) Moteur électrique (mécanisme de levage)	F 38
Wirbelstrombremse Eddy current brake Frein à courants parasites	F 44

Gegenausleger
Counterjib/Contre-flèche

10

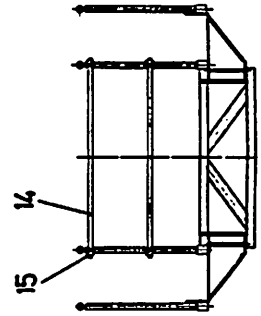
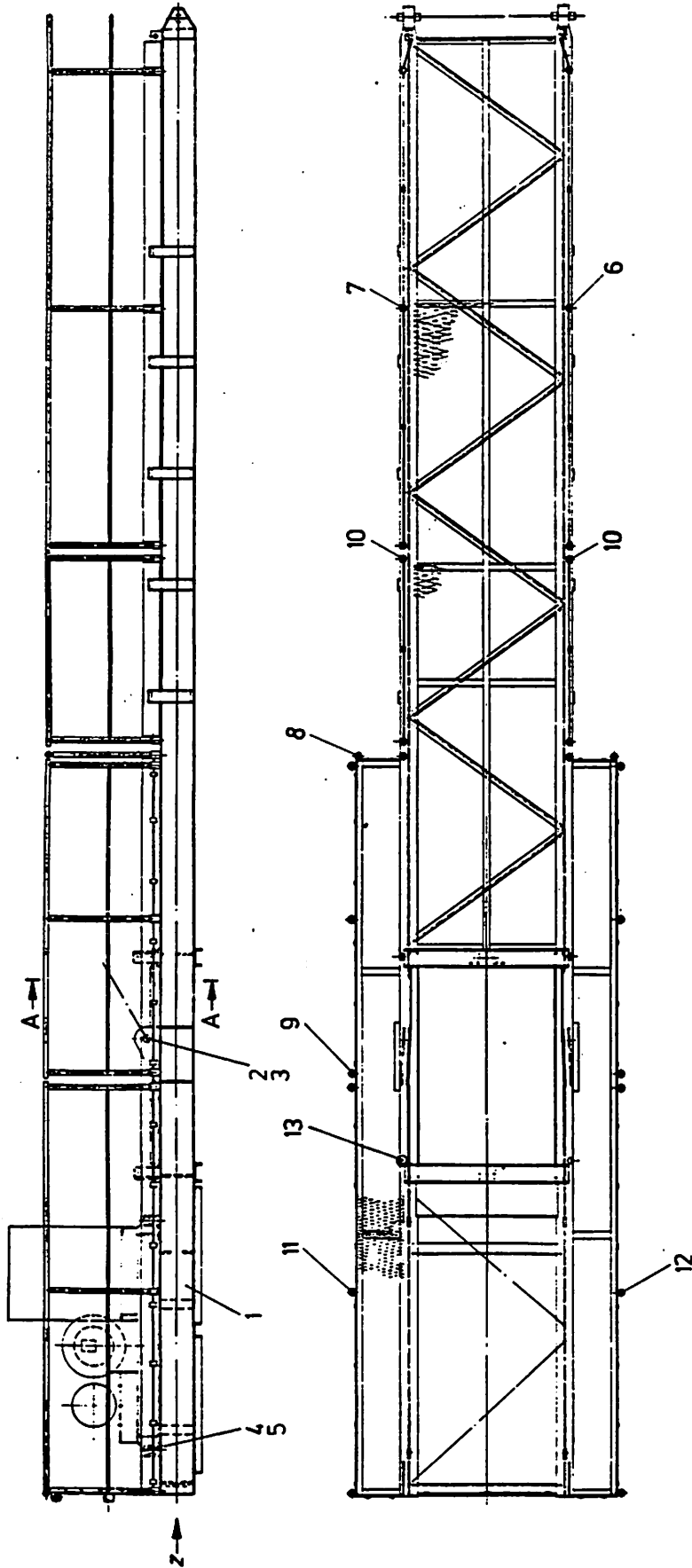

Schnitt A-A
section/coupe

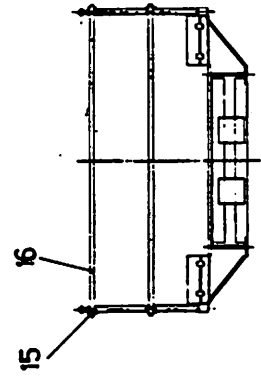

Ansicht Z
view/vue

Gegenausleger
Counterjib/Contre-flèche

Bestell-Nr. : 9571 710 01
order no.
no. de comm.

Zeichn.-Nr. : C 041.001 - 711.000
drawing no.
plan no.

bestehend aus:
consist. of
compose de

Teil-Nr. part no. pièce no.	Bestell-Nr. order no. no. de comm.	Teilbenennung designation désignation	Anz. qty. nbre	Zeichn.-Nr. drawing no. plan no.
1	9571 711 01	Gegenausleger counterjib/contre-flèche	1	C041.001-711.111
2	9975 009 01	Bolzen Form 200 pin/axe	2	BOL LN17-13.02
3	4330 105 01	Splint 10x90 DIN 94 cotter pin/goupille fendue	4	
4	9978 272 01	Bolzen Form 200 pin/axe	4	BOL LN24-09.13
5	4331 009 01	Federstecker Mubea 8mm spring plug/goupille à ressort	8	
6	9571 749 01	Geländer railing/garde-fou	1	C041.001-711.151
7	9571 750 01	Geländer railing/garde-fou	1	C041.001-711.152
8	9880 027 01	Geländer railing/garde-fou	2	PAG400HB002-110
9	9880 036 01	Geländer railing/garde-fou	2	PAG400HB204-110
10	9880 224 01	Geländer railing/garde-fou	2	PAG400LB103-110
11	9571 716 01	Geländer railing/garde-fou	1	C041.001-711.157
12	9571 717 01	Geländer railing/garde-fou	1	C041.001-711.158
13	9571 751 01	Geländer railing/garde-fou	2	C041.001-711.159
14	9539 711 01	Geländerrohr railing pipe/tuyau de garde-fou	4	C034.001-711.161
15	4331 013 01	Federstecker Mubea 7mm spring plug/goupille à ressort	12	
16	9571 718 01	Geländerrohr railing pipe/tuyau de garde-fou	2	C041.001-711.163

Gegenausleger-Abspannung

Counterjib suspension/Haubanage de contre-flèche

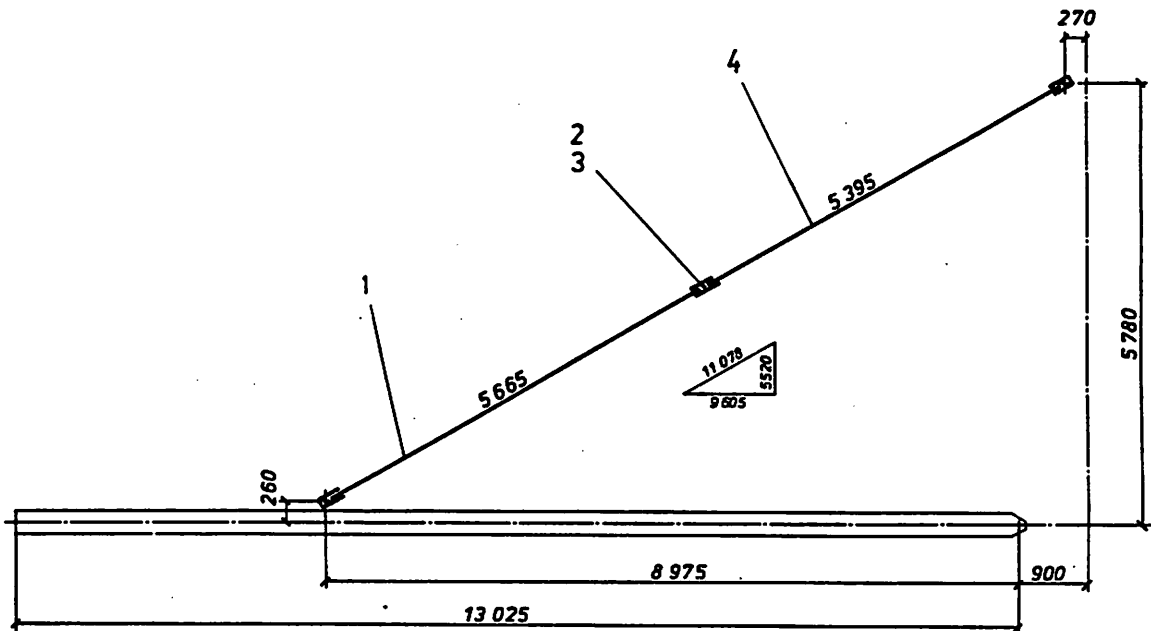

Bestell-Nr. : 9571 800 01
 order no.
 no. de comm.

Zeichn.-Nr. : C 041.001 - 814.100
 drawing no.
 plan no.

bestehend aus:
 consist. of
 compose de

Teil-Nr. part no. pièce no.	Bestell-Nr. order no. no. de comm.	Teilbenennung designation désignation	Anz. qty. nbre	Zeichn.-Nr. drawing no. plan no.
1	9571 802 01	Zugstange con-rod/tirant	2	C041.001-814.111
2	9710 177 01	Bolzen Form 200 pin/axe	2	BOL IN17-13.28
3	4330 105 01	Splint 10x90 DIN 94 cotter pin/goupille fendue	4	
4	9539 801 01	Zugstange con-rod/tirant	2	C034.001-814.131

E-Installation Gegenausleger

Electric installation counter jib/
Installation électrique contre-flèche

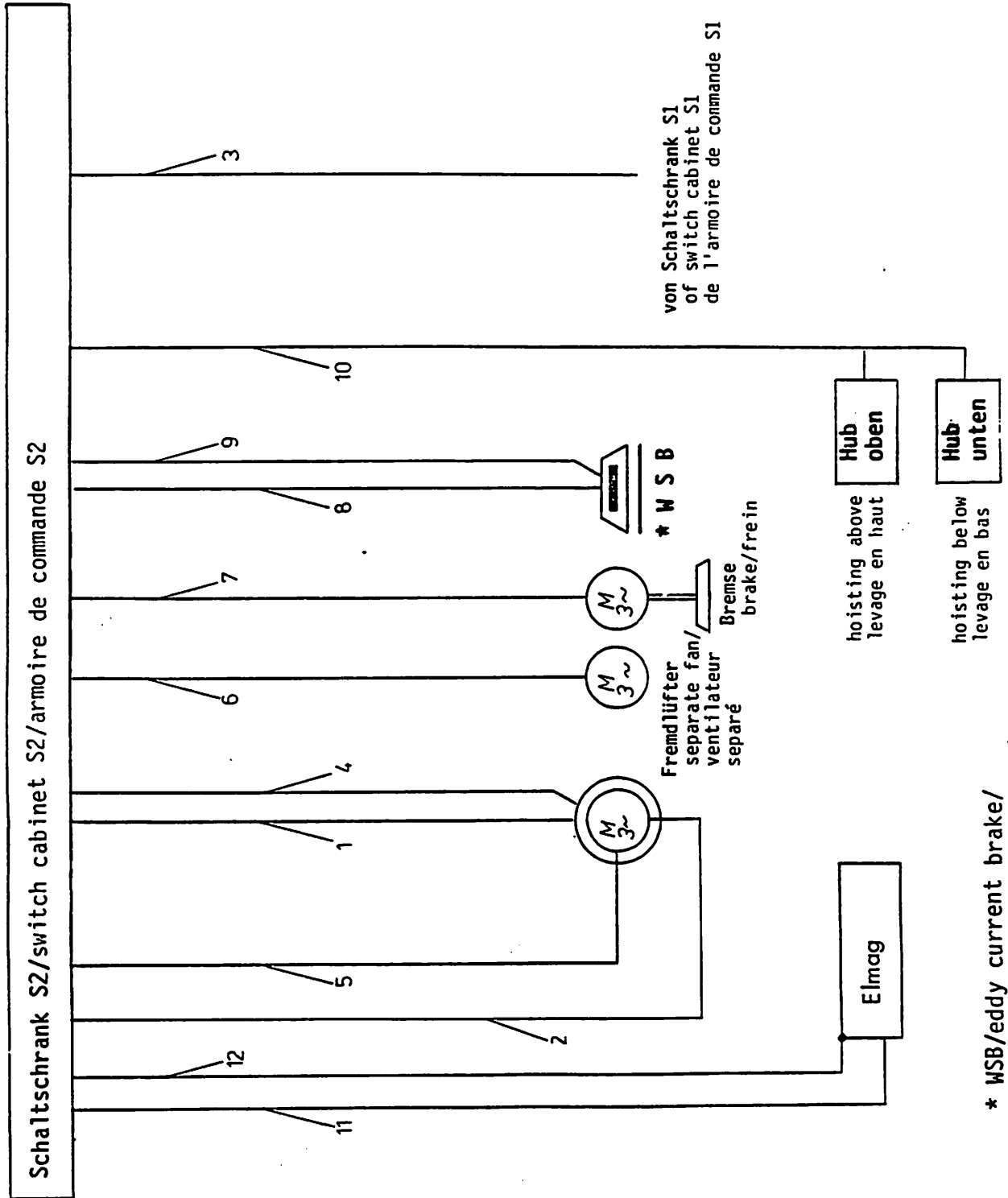

E-Installation Gegenausleger

Electric installation counterjib/Installation électrique contre-flèche

Bestell-Nr. : 9571 887 01
order no.
no. de comm.

Zeichn.-Nr. : C 041.800 - 721.000
drawing no.
plan no.

bestehend aus:
consist. of
compose de

Teil-Nr. part no. pièce no.	Bestell-Nr. order no. no. de comm.	Teilbenennung designation désignation	Anz. qty. nbre	Zeichn.-Nr. drawing no. plan no.
1	6002 245 01	Leitung H 07 RN-F 4G 35 3,8m cable/ligne	1	
2	6002 247 01	Leitung H 07 RN-F 4G 50 3,8m cable/ligne	1	
3	6002 245 01	Leitung H 07 RN-F 4G 35 22,0m cable/ligne	1	
4	6003 510 01	Flexleitung 3x1,5x4200 flexible cable/ligne flexible	1	
5	6003 522 01	Flexleitung 4x1,5x4600 flexible cable/ligne flexible	1	
6	6003 522 01	Flexleitung 4x1,5x4400 flexible cable/ligne flexible	1	
7	6003 522 01	Flexleitung 4x1,5x5400 flexible cable/ligne flexible	1	
8	6003 511 01	Flexleitung 3x2,5x4800 flexible cable/ligne flexible	1	
9	6003 510 01	Flexleitung 3x1,5x4800 flexible cable/ligne flexible	1	
10	6003 552 01	Flexleitung 7x1,5x4000 flexible cable/ligne flexible	1	
11	6003 522 01	Flexleitung 4x1,5x4000 flexible cable/ligne flexible	2	
12	6001 441 01	Leitung PVC H 07 V-K 3,8m cable/ligne	1	
13	9520 712 01	Schelle clip/bride de fixation	3	

Getrieberahmen
Gear frame/Cadre de mécanisme

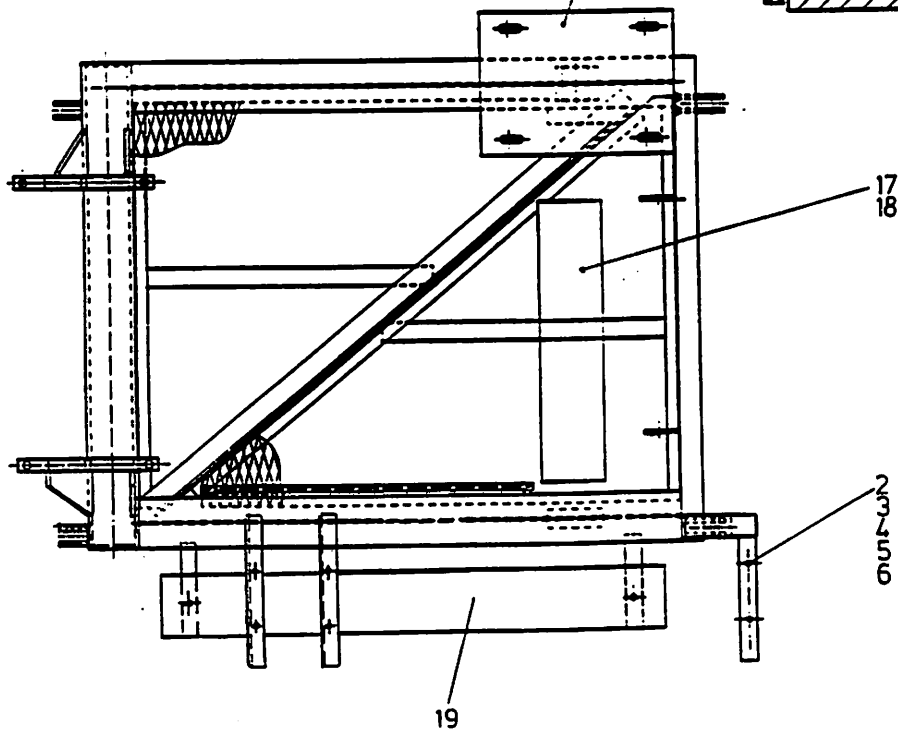
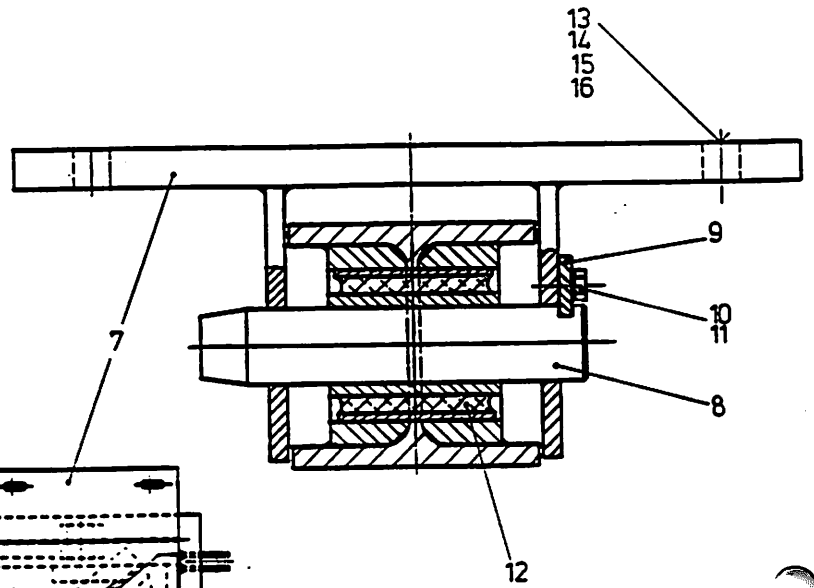
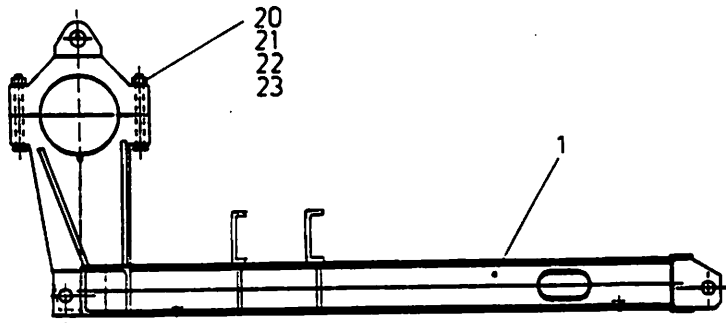

Getrieberahmen

Gear frame/Cadre de mécanisme

Bestell-Nr. : 9571 762 01
order no.
no. de comm.

Zeichn.-Nr. : C 041.001 - 721.500
drawing no.
plan no.

bestehend aus:
consist. of
compose de

Teil-Nr. part no. pièce no.	Bestell-Nr. order no. no. de comm.	Teilbenennung designation désignation	Anz. qty. nbre	Zeichn.-Nr. drawing no. plan no.
1	9571 763 01	Rahmen frame/cadre	1	C041.001-721.511
2	4200 016 01	Scheibe 13 DIN 125-St washer/rondelle	6	
3	4203 003 01	Scheibe 14 DIN 434 washer/rondelle	6	
4	4065 131 01	Schraube M 12x40 DIN 933-8.8 bolt/vis	6	
5	4115 048 01	Mutter M 12 DIN 934-10 nut/écrou	6	
6	4239 017 01	Sicherungsscheibe VS 12 lock washer/rondelle d'arrêt	6	
7	9571 765 01	Motorauflage motor base/base de moteur	1	C041.001-721.521
8	9971 711 01	Achse Form 100 axle/essieu	1	ACH LN47-11.23
9	9970 403 01	Achshalter axle support/ support d'essieu	1	AHA LN 4/3
10	4065 125 01	Schraube M 12x20 DIN 933-8.8 bolt/vis	2	
11	4239 017 01	Sicherungsscheibe VS 12 lock washer/rondelle d'arrêt	2	
12	7043 304 01	Buchse bush/douille	1	
13	4062 138 01	Schraube M 16x80 DIN 931-10.9 bolt/vis	4	
14	4215 002 01	Scheibe 17 DIN 6916 washer/rondelle	8	
15	4115 050 01	Mutter M 16 DIN 934-10 nut/écrou	4	
16	4239 020 01	Sicherungsscheibe VS 16 lock washer/rondelle d'arrêt	4	
17	6381 102 01	Kabelbahn cable track/ voite de câble	900mm	
18	6381 129 01	Deckel cover/covercle	900mm	
19	6381 124 01	Kabelbahn cable track/ voite de câble	1900mm	
20	4062 445 01	Schraube M 24x230 DIN 931-10.9 bolt/vis	4	

Teil-Nr. part no. pièce no.	Bestell-Nr. order no. no. de comm.	Teilbenennung designation désignation	Anz. qty. nbre	Zeichn.-Nr. drawing no. plan no.
21	4215 004 01	Scheibe 25 DIN 6916 washer/rondelle	8	
22	4115 054 01	Mutter M 24 DIN 934-10 nut/écrou	4	Liebherrnorm 30/17
23	4235 012 01	Sicherungsmutter M 24 DIN 7967 counternut/contre-écrou	4	

Hubwerk

Hoist gear/Mécanisme de levage

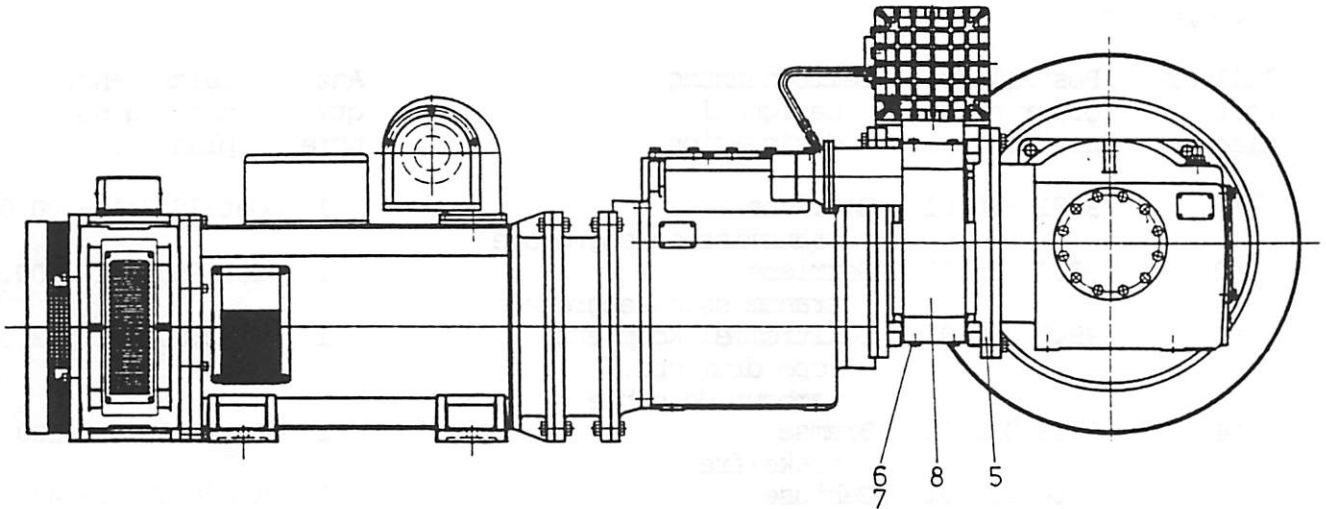

Pultschild
desk sign/
signe de pupitre

28

29

3

2

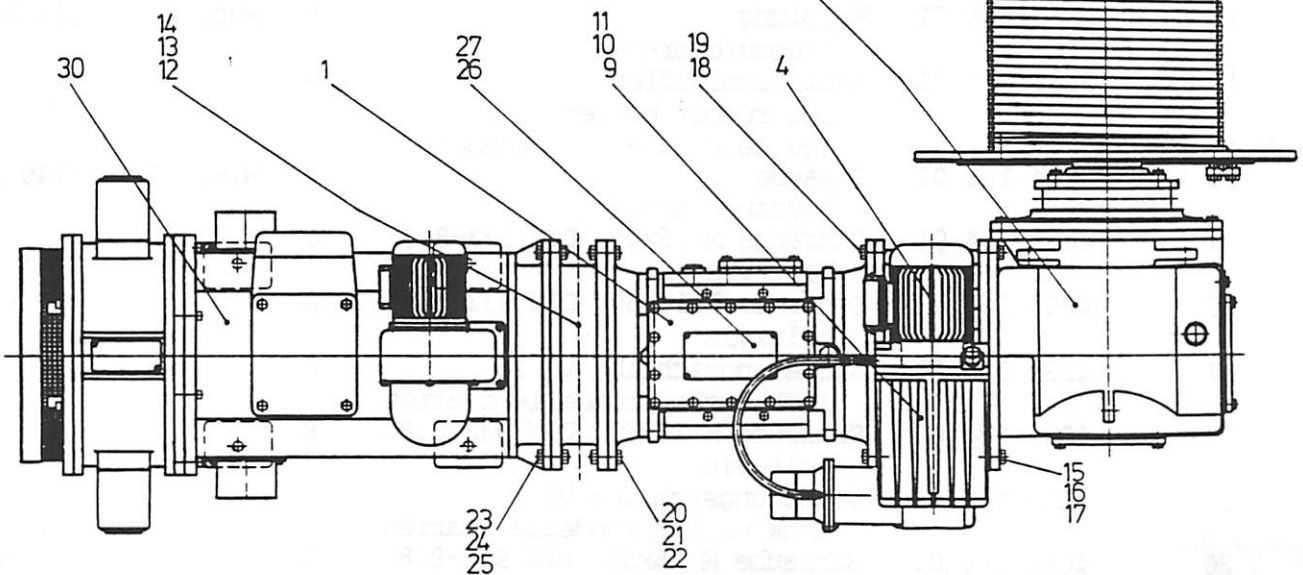

Hubwerk

Hoist gear/Mécanisme de levage

Bestell-Nr. : 9943 080 01
order no.
no. de comm.

Zeichn.-Nr. : WiW 260 JX 421 - 740.000
drawing no.
plan no.

bestehend aus:
consist. of
compose de

Teil-Nr. part no. pièce no.	Bestell-Nr. order no. no. de comm.	Teilbenennung designation désignation	Anz. qty. nbre	Zeichn.-Nr. drawing no. plan no.
*1	9381 840 01	Getriebe transmission/engrenage	1	Get320JX411-100.000
*2	9380 465 01	Getriebe transmission/engrenage	1	Get1250MW421-100.000
*3	9943 082 01	Seiltrommel komplett rope drum cpl./ tambour de câble	1	WiW260JX421-742.000
*4	9713 810 01	Bremse brake/frein	1	Bre1650BY401-100.000
5	9944 106 01	Gehäuse housing/carter	1	WiW280JX401-743.201
6	4065 095 01	Schraube M 10x16 DIN 933-8.8 bolt/vis	4	
7	4239 015 01	Sicherungsscheibe VS 10 lock washer/rondelle d'arrêt	4	
8	9943 037 01	Abdeckung covering/couverture	1	WiW260JX401-743.300
9	9831 810 01	Kupplung clutch/embrayage	1	Kup250BS401-100.000
10	5031 298 01	Satz Gummipuffer set rubber buffer/ jeu de pneu en caoutchouc	1	
11	9943 039 01	Nabe hub/moyeu	1	WiW260JX401-746.121
12	9831 086 01	Kupplung clutch/embrayage	1	Kup60BS401-100.000
13	5031 297 01	Satz Gummipuffer set rubber buffer/ jeu de pneu en caoutchouc	1	
14	9944 108 01	Gehäuse housing/carter	1	WiW280JX401-746.301
15	4065 164 01	Schraube M 16x50 DIN 933-8.8 bolt/vis	6	
16	4065 166 01	Schraube M 16x60 DIN 933-8.8 bolt/vis	2	
17	4239 020 01	Sicherungsscheibe VS 16 lock washer/rondelle d'arrêt	8	
18	4065 164 01	Schraube M 16x50 DIN 933-8.8 bolt/vis	8	
19	4239 020 01	Sicherungsscheibe VS 16 lock washer/rondelle d'arrêt	8	
20	4061 166 01	Schraube M 16x55 DIN 931-8.8 bolt/vis	8	

Teil-Nr. part no. pièce no.	Bestell-Nr. order no. no. de comm.	Teilbenennung designation désignation	Anz. qty. nbre	Zeichn.-Nr. drawing no. plan no.
21	4115 050 01	Mutter M 16 DIN 934-10 nut/écrou	8	
22	4239 020 01	Sicherungsscheibe VS 16 lock washer/rondelle d'arrêt	16	
23	4061 166 01	Schraube M 16x55 DIN 931-8.8 bolt/vis	8	
24	4115 050 01	Mutter M 16 DIN 934-10 nut/écrou	8	
25	4239 020 01	Sicherungsscheibe VS 16 lock washer/rondelle d'arrêt	16	
26	9943 086 01	Leistungsschild output plate/ plaquette de capacité	1	WiW260JX421-747.711
27	4315 001 01	Kerbnagel 2x3 DIN 1476 notched nail/clou conique	4	
28	9943 087 01	Pultschild desk sign/signé de pupitre	1	WiW260JX421-747.731
*29	9957 738 01	Spindelenschalter rotating limit switch/ interrupteur de fin de course de tige	1	WiW220PX024-748.000
*30	6101 808 01	E-Motor E20.0930-000/204 electric motor/moteur électrique	1	E20.0930 C 000/124

Getriebe
Transmission/Engrenage

Pl.

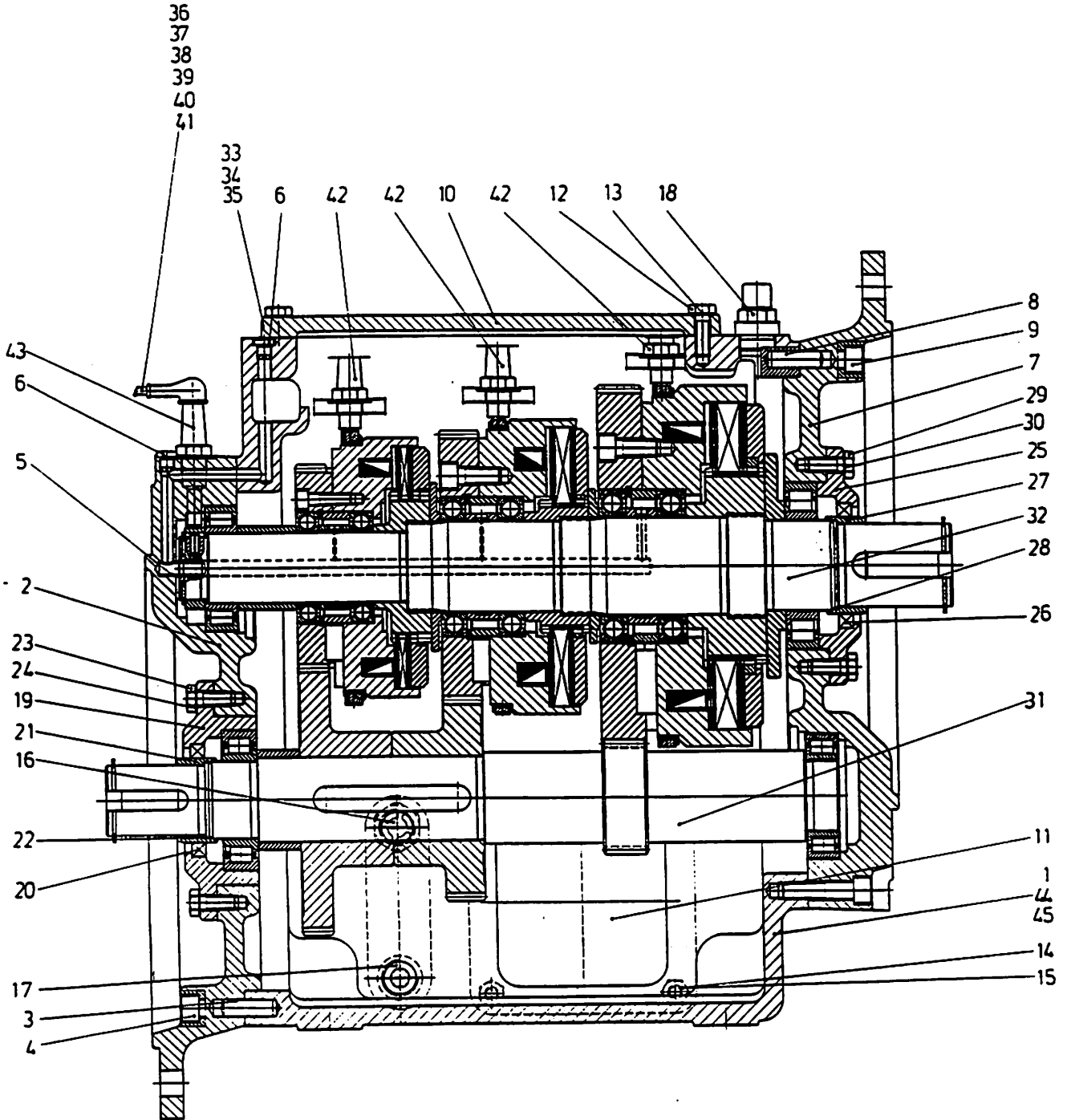

Öleinfüllmenge: 18 ltr.
oil quantity/quantité d'huile

Getriebe

Transmission/Engrenage

Bestell-Nr. : 9381 840 01
order no.
no. de comm.

Zeichn.-Nr. : Get 320 JX 411 - 100.000
drawing no.
plan no.

bestehend aus:
consist. of
compose de

Teil-Nr. part no. pièce no.	Bestell-Nr. order no. no. de comm.	Teilbenennung designation désignation	Anz. qty. nbre	Zeichn.-Nr. drawing no. plan no.
1	9381 802 01	Gehäuse housing/carter	1	Get320JX401-111.101
2	9381 803 01	Deckel cover/couvercle	1	Get320JX401-111.111
3	4307 094 01	Zylinderstift 12 m6 x40 DIN 6325 straight pin/ goupille cylindrique	2	
4	4042 122 01	Schraube M 12x50 DIN 912-8.8 bolt/vis	20	
5	9381 833 01	Rohr tube/tuyau	1	Get320JX401-111.118
6	4775 105 01	Verschlußschraube M 10x1-ED screw plug/vis de fermeture	2	
7	9381 804 01	Deckel cover/couvercle	1	Get320JX401-111.121
8	4307 094 01	Zylinderstift 12 m6 x40 DIN 6325 straight pin/ goupille cylindrique	2	
9	4042 122 01	Schraube M 12x50 DIN 912-8.8 bolt/vis	20	
10	9381 805 01	Deckel cover/covercle	1	Get320JX401-111.131
11	9381 806 01	Deckel cover/covercle	1	Get320JX401-111.132
12	4065 101 01	Schraube M 10x30 DIN 933-8.8 bolt/vis	14	
13	4239 015 01	Sicherungsscheibe VS 10 lock washer/rondelle d'arrêt	14	
14	4065 101 01	Schraube M 10x30 DIN 933-8.8 bolt/vis	4	
15	4239 015 01	Sicherungsscheibe VS 10 lock washer/rondelle d'arrêt	4	
16	7743 221 01	Ölschauglas M 26x1,5 Modell 240/AS oil sight glass/ indicateur de niveau d'huile à regard	1	
17	4775 115 01	Verschlußschraube M 26x1,5-ED screw plug/vis de fermeture	1	
18	7211 088 01	Belüftungs und Entlüftungsfilter ventilating filter/ filtre de ventilation	1	
19	9381 808 01	Deckel cover/couvercle	1	Get320JX401-112.111

Teil-Nr. part no. pièce no.	Bestell-Nr. order no. no. de comm.	Teilbenennung designation désignation	Anz. qty. nbre	Zeichn.-Nr. drawing no. plan no.
20	7100 227 01	Wellendichtring 60x80x10/12 AS DIN 3760 rotary shaft seal/ bague à lèvres avec ressort	1	
21	9381 809 01	Distanzring distance ring/ rondelle entretoise	1	Get320JX401-112.113
22	7264 354 01	O-Ring 50x2 O-ring/ anneau torique d'étanchéité	1	
23	4065 099 01	Schraube M 10x25 DIN 933-8.8 bolt/vis	6	
24	4239 015 01	Sicherungsscheibe VS 10 lock washer/rondelle d'arrêt	6	
25	9381 810 01	Deckel cover/couvercle	1	Get320JX401-112.121
26	7100 588 01	Wellendichtring 70x90x10 BASL rotary shaft seal/ bague à lèvres avec ressort	1	
27	9381 811 01	Distanzring distance ring/ rondelle entretoise	1	Get320JX401-112.123
28	7264 207 01	O-Ring 62x2 O-ring/ anneau torique d'étanchéité	1	
29	4065 099 01	Schraube M 10x25 DIN 933-8.8 bolt/vis	6	
30	4239 015 01	Sicherungsscheibe VS 10 lock washer/rondelle d'arrêt	6	
*31	9381 841 01	Welle 1 komplett shaft 1 cpl./arbre 1 cpl.	1	Get320JX411-121.000
*32	9381 844 01	Welle 2 komplett shaft 2 cpl./arbre 2 cpl.	1	Get320JX411-122.000
33	9381 834 01	Abdeckung covering/coverture	2	Get320JX401-191.101
34	4065 094 01	Schraube M 10x12 DIN 933-8.8 bolt/vis	4	
35	4239 015 01	Sicherungsscheibe VS 10 lock washer/rondelle d'arrêt	4	
36	6024 009 01	Verschraubung C4 PG 9x7-9 DIN 46320 threaded union/vissage	2	
37	6001 440 01	Leitung ligne/câble	100mm	
38	6023 011 01	Kabelschuh cable shoe/patin de câble	9	
39	4001 030 01	Schraube M 5x6 DIN 84-5.8 bolt/vis	3	
40	4200 008 01	Scheibe 5,3 DIN 125-St washer/rondelle	3	
41	4252 008 01	Fächerscheibe A 5,3 DIN 6798 fan washer/ rondelle en éventail	6	
42	6912 901 01	Stromzuführung TSN 8 Nr.6553 102 004 current supply/ amenée de courant	6	

Teil-Nr. part no. pièce no.	Bestell-Nr. order no. no. de comm.	Teilbenennung designation désignation	Anz. qty. nombre	Zeichn.-Nr. drawing no. plan no.
43	6912 916 01	Stromzuführung TSL 8 Nr.6553 103 050 current supply/ amenée de courant	1	
44	9381 853 01	Typenschild type plate plaque sinalétique	1	Get320JX411-201.000
45	4315 001 01	Kerbnagel 2x3 DIN 1476 nothed nail/ clou conique	4	

Welle 1 komplett
Shaft 1 cpl./Arbre 1 cpl.

Pl.

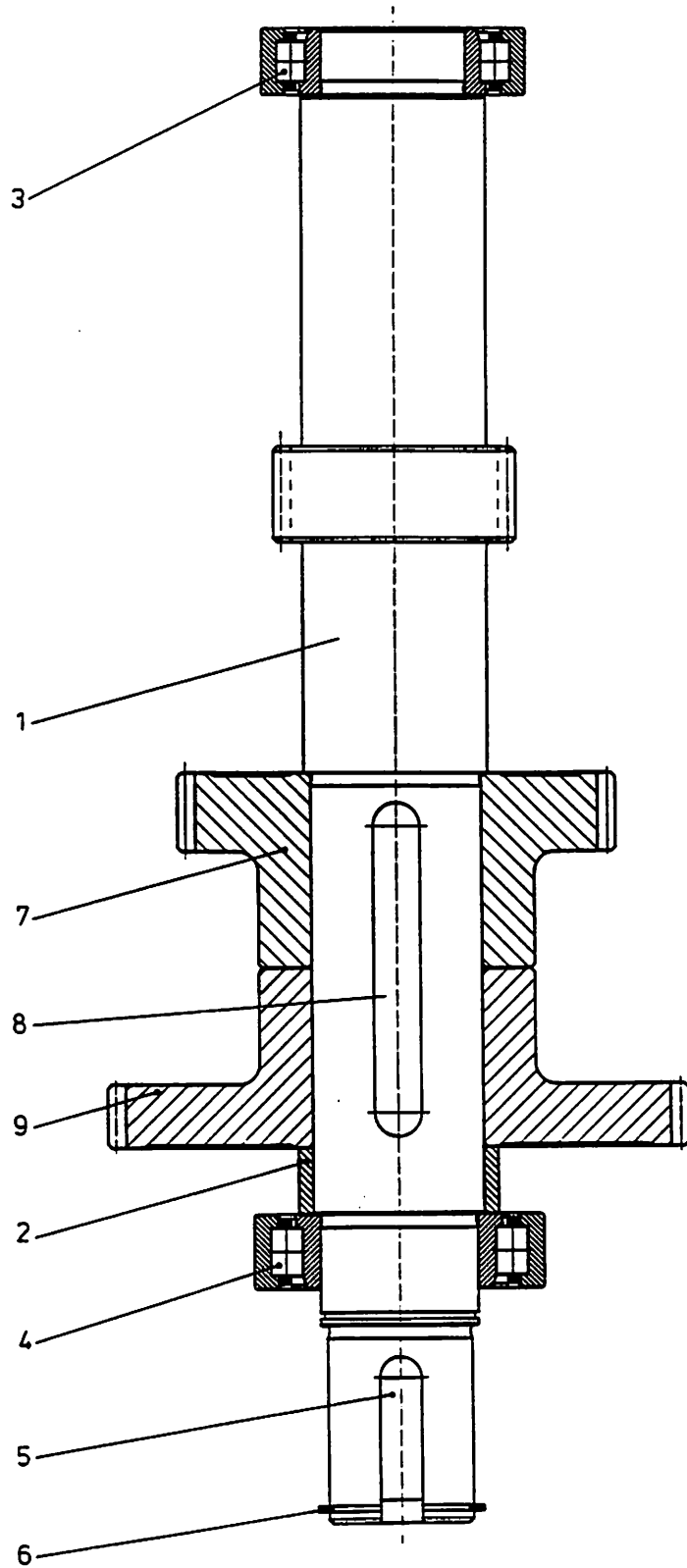

Welle 1 komplett

Shaft 1 cpl./Arbre 1 cpl.

Bestell-Nr. : 9381 841 01
order no.
no. de comm.

Zeichn.-Nr. : Get 320 JX 411 - 121.000
drawing no.
plan no.

bestehend aus:
consist. of
compose de

Teil-Nr. part no. pièce no.	Bestell-Nr. order no. no. de comm.	Teilbenennung designation désignation	Anz. qty. nbre	Zeichn.-Nr. drawing no. plan no.
1	9381 813 01	Welle shaft/arbre	1	Get320JX401-121.101
2	9381 814 01	Distanzring distance ring/ rondelle entretoise	1	Get320JX401-121.111
3	7464 137 01	Lager DIN 5412 NJ 2210 bearing/palier	1	
4	7464 128 01	Lager DIN 5412 NJ 2211E bearing/palier	1	
5	4342 004 01	Paßfeder B 14x9x40 DIN 6885 feather key/ clavette parallèle fixée par vis	1	
6	4280 042 01	Sicherungsring 50x2 DIN 471 locking ring/circlip extérieur	1	
7	9381 842 01	Stirnrad spur wheel/roue droite	1	Get320JX411-121.203
8	4340 277 01	Paßfeder A 18x11x110 DIN 6885 feather key/ clavette parallèle fixée par vis	1	
9	9381 843 01	Stirnrad spur wheel/roue droite	1	Get320JX411-121.303

Welle 2 komplett
Shaft 2 cpl./Arbre 2 cpl.

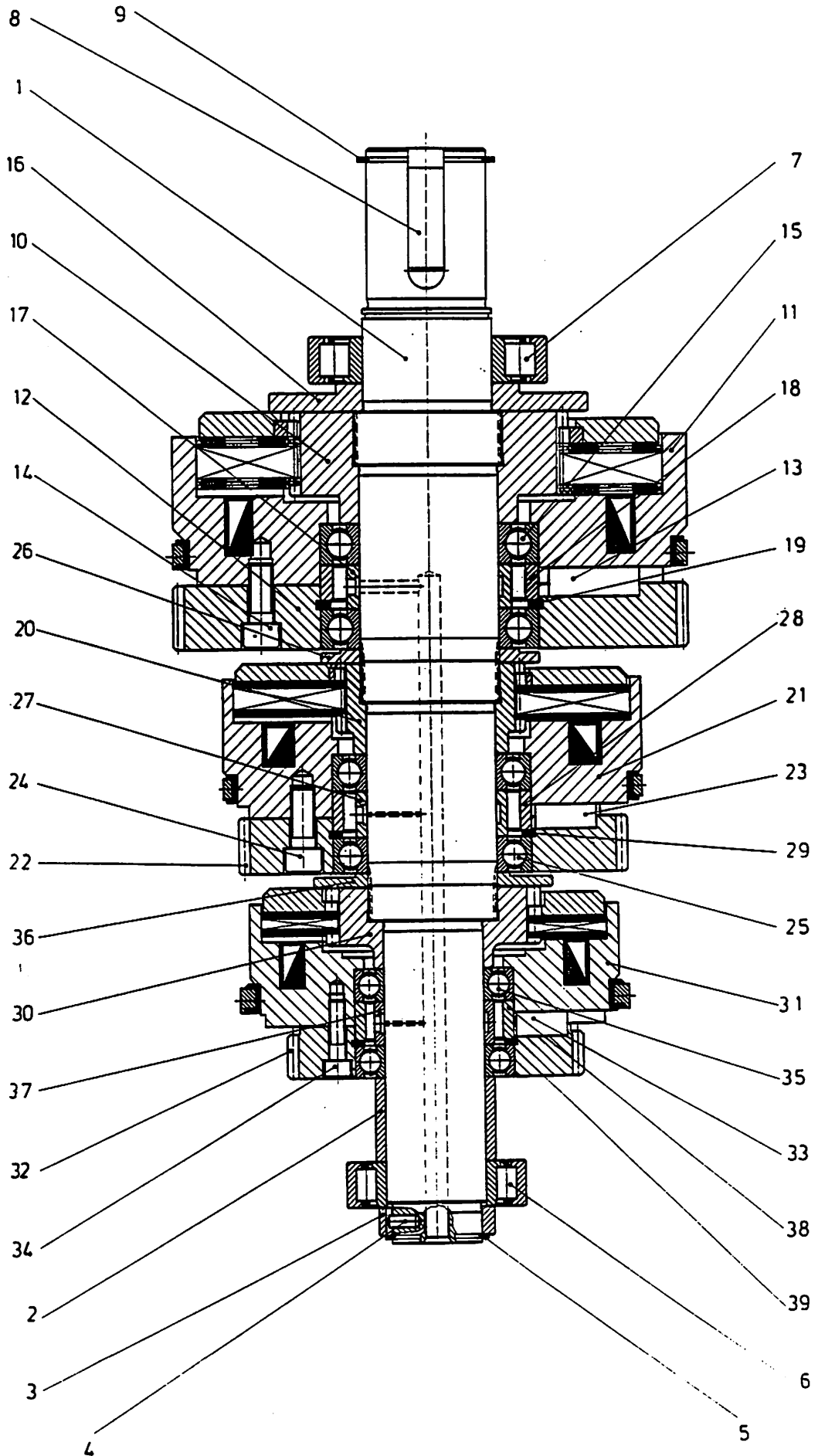

Welle 2 komplett

Shaft 2 cpl./Arbre 2 cpl.

Bestell-Nr. : 9381 844 01
order no.
no. de comm.

Zeichn.-Nr. : Get 320 JX 411 - 122.000
drawing no.
plan no.

bestehend aus:
consist. of
compose de

Teil-Nr. part no. pièce no.	Bestell-Nr. order no. no. de comm.	Teilbenennung designation désignation	Anz. qty. nbre	Zeichn.-Nr. drawing no. plan no.
1	9381 845 01	Welle shaft/arbre	1	Get320JX411-122.101
2	9381 846 01	Distanzring distance ring/ rondelle entretoise	1	Get320JX411-122.111
3	9381 820 01	Distanzring distance ring/ rondelle entretoise	1	Get320JX401-122.121
4	4307 032 01	Zylinderstift 6 m6 x16 DIN6325 straight pin/ goupille cylindrique	1	
5	4280 039 01	Sicherungsring 45x1,75 DIN 471 locking ring/circlip extérieur	1	
6	7464 137 01	Lager DIN 5412 NJ 2210 bearing/palier	1	
7	7463 101 01	Lager DIN 5412 NJ 213E bearing/palier	1	
8	4342 136 01	Paßfeder B 18x11x50 DIN 6885 feather key/ clavette parallèle fixée par vis	2	
9	4280 049 01	Sicherungsring 60x2 DIN 471 locking ring/circlip extérieur	1	
10	9381 821 01	Lamellenträger lamella clamp/ attache de lamelle	1	Get320JX401-122.201
11	5030 764 01	Kupplung Typ EMD 100/140 clutch/embrayage	1	
12	9381 822 01	Stirnrad spur wheel/roue droite	1	Get320JX401-122.203
13	4341 086 01	Paßfeder AB 25x14x45 DIN 6885 feather key/ clavette parallèle fixée par vis	2	
14	4042 116 01	Schraube M 12x30 DIN 912-8.8 bolt/vis	4	
15	7451 214 01	Lager DIN 625 Nr.6014 bearing/palier	2	
16	9381 823 01	Scheibe washer/rondelle	1	Get320JX401-122.241
17	9381 429 01	Distanzring distance ring/ rondelle entretoise	1	Get450JX401-122.351

Teil-Nr. part no. pièce no.	Bestell-Nr. order no. no. de comm.	Teilbenennung designation désignation	Anz. qty. nbre	Zeichn.-Nr. drawing no. plan no.
18	9381 430 01	Distanzring distance ring/ rondelle entretoise	1	Get450JX401-122.361
19	4281 035 01	Sicherungsring 110x4 DIN 472 locking ring/circlip intérieur	1	
20	9381 824 01	Lamellenträger lamella clamp/ attache de lamelle	1	Get320JX401-122.301
21	5030 761 01	Kupplung Typ EMT 60/80K clutch/embrayage	1	
22	9381 847 01	Stirnrad spur wheel/roue droite	1	Get320JX411-122.303
23	4341 228 01	Paßfeder AB 20x12x28 DIN 6885 feather key/ clavette parallèle fixée par vis	2	
24	4042 116 01	Schraube M 12x30 DIN 912-8.8 bolt/vis	4	
25	7451 213 01	Lager DIN 625 Nr.6013 bearing/palier	2	
26	9381 433 01	Scheibe washer/rondelle	1	Get450JX401-122.441
27	9381 434 01	Distanzring distance ring/ rondelle entretoise	1	Get450JX401-122.451
28	9381 435 01	Distanzring distance ring/ rondelle entretoise	1	Get450JX401-122.461
29	4281 031 01	Sicherungsring 100x3 DIN 472 locking ring/circlip intérieur	1	
30	9381 848 01	Lamellenträger lamella clamp/ attache de lamelle	1	Get320JX411-122.401
31	5030 778 01	Kupplung Typ EMT 40 K clutch/embrayage	1	
32	9381 849 01	Stirnrad spur wheel/roue droite	1	Get320JX411-122.403
33	4341 309 01	Paßfeder AB 20x12x18 DIN 6885 feather key/ clavette parallèle fixée par vis	2	
34	4042 067 01	Schraube M 8x30 DIN 912-8.8 bolt/vis	6	
35	7451 210 01	Lager DIN 625 Nr.6010 bearing/palier	2	
36	9381 850 01	Scheibe washer/rondelle	1	Get320JX411-122.441
37	9381 851 01	Distanzring distance ring/ rondelle entretoise	1	Get320JX411-122.451
38	9381 852 01	Distanzring distance ring/ rondelle entretoise	1	Get320JX411-122.461
39	4281 025 01	Sicherungsring 80x2,5 DIN 472 locking ring/circlip intérieur	1	

Getriebe
Transmission/Engrenage

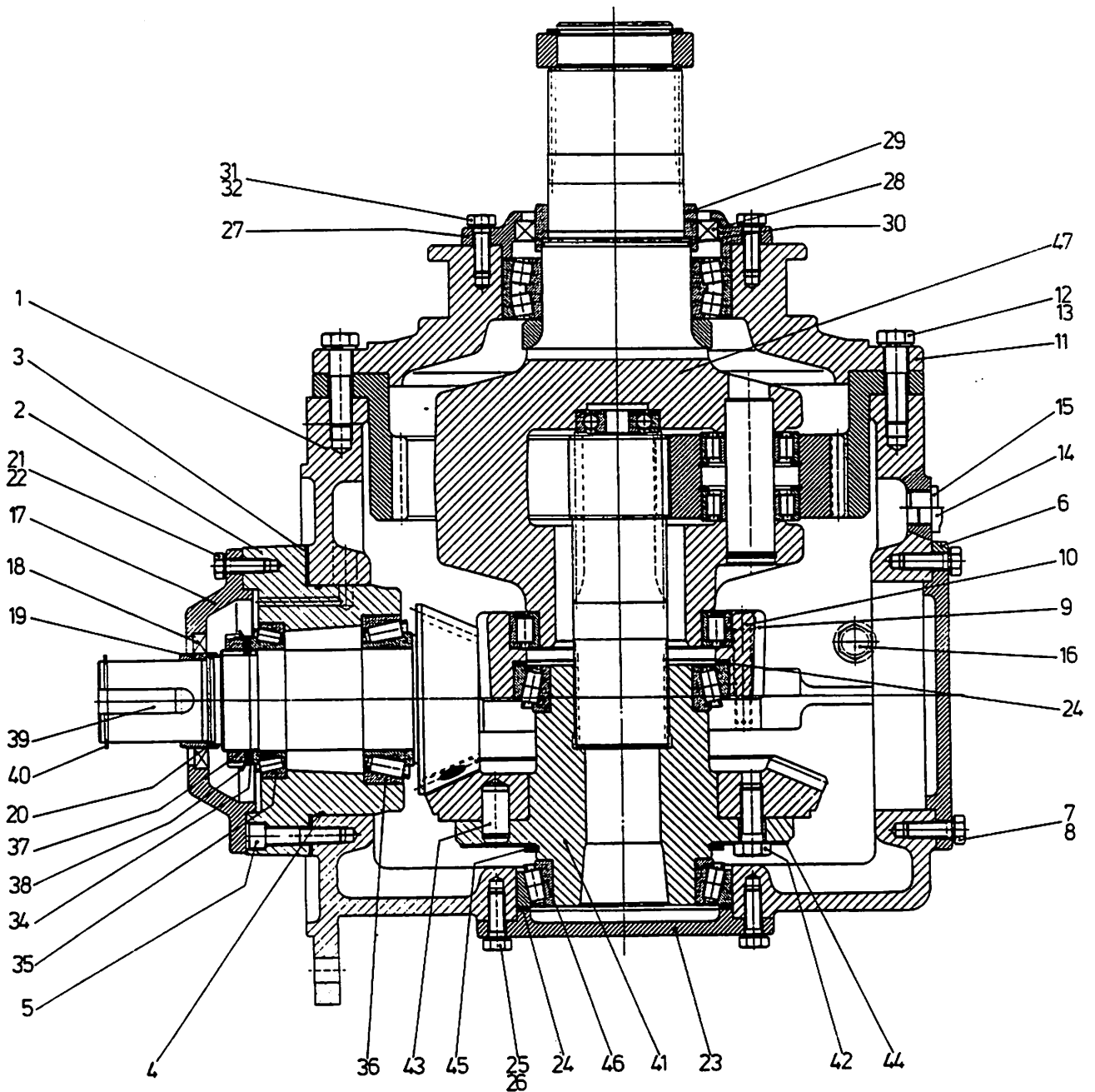

Öleinfüllmenge: 15,0 l
oil quantity/quantité d'huile

Getriebe

Transmission/Engrenage

Bestell-Nr. : 9380 465 01^{pl.}
 order no.
 no. de comm.

Zeichn.-Nr. : Get 1250 MW 421 - 100.000
 drawing no.
 plan no.

bestehend aus:
 consist. of
 compose de

Teil-Nr. part no. pièce no.	Bestell-Nr. order no. no. de comm.	Teilbenennung designation désignation	Anz. qty. nbre	Zeichn.-Nr. drawing no. plan no.
1	9380 472 01	Gehäuse housing/carter	1	Get1250MW401-111.101
2	9380 473 01	Lagerflansch bearing flange/ bride de palier	1	Get1250MW401-111.111
3	9380 497 01	Paßscheibe shim ring/ rondelle ajuste	1	Get1250MW401-111.112
4	7264 277 01	O-Ring 160x3 O-ring/ anneau torique d'étanchéité	1	
5	4042 123 01	Schraube M 12x55 DIN 912-8.8 bolt/vis	12	
6	9380 474 01	Deckel cover/couvercle	1	Get1250MW401-111.121
7	4065 130 01	Schraube M 12x35 DIN 933-8.8 bolt/vis	6	
8	4239 017 01	Sicherungsscheibe VS 12 lock washer/rondelle d'arrêt	6	
9	9380 475 01	Gehäusesteg part of housing/ pièce de carter	1	Get1250MW401-111.131
10	4042 126 01	Schraube M 12x70 DIN 912-8.8 bolt/vis	10	
11	9380 476 01	Stützflansch supporting flange/ bride de support	1	Get1250MW401-111.141
12	4061 167 01	Schraube M 16x60 DIN 931-8.8 bolt/vis	14	
13	4239 020 01	Sicherungsscheibe VS 16 lock washer/rondelle d'arrêt	14	
14	7743 221 01	Ölschauglas M 26x1,5 Modell 240/AS oil sight glass/ indicateur de niveau d'huile à regard	1	
15	4775 115 01	Verschlußschraube M 26x1,5-ED screw plug/vis de fermeture	1	
16	7211 088 01	Belüftungs und Entlüftungsfilter ventilating filter/ filtre de ventilation	1	
17	9380 478 01	Deckel cover/couvercle	1	Get1250MW401-112.111

Teil-Nr. part no. pièce no.	Bestell-Nr. order no. no. de comm.	Teilbenennung designation désignation	Anz. qty. nbre	Zeichn.-Nr. drawing no. plan no.
18	7100 532 01	Wellendichtring 70x100x10 AS DIN 3760 rotary shaft seal/ bague à lèvres avec ressort	1	
19	9381 811 01	Distanzring distance ring/ rondelle entretoise	1	Get320JX401-112.123
20	7264 207 01	O-Ring 62x2 O-ring/ anneau torique d'étanchéité	1	
21	4065 101 01	Schraube M 10x30 DIN 933-8.8 bolt/vis	6	
22	4239 015 01	Sicherungsscheibe VS 10 lock washer/rondelle d'arrêt	6	
23	9380 479 01	Deckel cover/couvercle	1	Get1250MW401-112.121
24	9380 498 01	Paßscheibe shim ring/ rondelle ajuste	2	Get1250MW401-112.122
25	4065 130 01	Schraube M 12x35 DIN 933-8.8 bolt/vis	12	
26	4239 017 01	Sicherungsscheibe VS 12 lock washer/rondelle d'arrêt	12	
27	9380 480 01	Deckel cover/couvercle	1	Get1250MW401-112.131
28	7100 310 01	Wellendichtring 120x150x15 AS DIN 3760 rotary shaft seal/ bague à lèvres avec ressort	1	
29	9380 481 01	Distanzring distance ring/ rondelle entretoise	1	Get1250MW401-112.133
30	7264 521 01	O-Ring 100x2,5 72NER/872 O-ring/ anneau torique d'étanchéité	1	
31	4065 130 01	Schraube M 12x35 DIN 933-8.8 bolt/vis	6	
32	4239 017 01	Sicherungsscheibe VS 12 lock washer/rondelle d'arrêt	6	
33	9380 482 01	Kegelradsatz bevel gear set/ jeu de roues coniques	1	Get1250MW401-120.000
34	9380 495 01	Scheibe washer/rondelle	1	Get1250MW401-121.111
35	7462 232 01	Lager DIN 720 Nr.32015X bearing/palier	1	
36	7462 465 01	Lager DIN 720 Nr.33115 bearing/palier	1	
37	7472 010 01	Nutmutter KM 15 M 75x2 slotted nut/ écrou rainure	1	
38	7472 207 01	Sicherungsblech MB 15 safety plate/ tôle d'arrêt	1	
39	4342 136 01	Paßfeder B 18x11x50 DIN 6885 feather key/ clavette parallèle fixée par vis	2	

Teil-Nr. part no. pièce no.	Bestell-Nr. order no. no. de comm.	Teilbenennung designation désignation	Anz. qty. nbre	Zeichn.-Nr. drawing no. plan no.
40	4280 049 01	Sicherungsring 60x2 DIN 471 locking ring/ circlip extérieur	1	
41	9380 485 01	Kegelradnabe bevel hub/ moyeu d'engrenage conique	1	Get1250MW401-122.101
42	4066 030 01	Schraube M 16x40 DIN 933-10.9 bolt/vis	8	
43	4307 122 01	Zylinderstift 20 m6 x40 DIN 6325 straight pin/ goupille cylindrique	4	
44	9380 496 01	Sicherungsblech safety plate/ tôle d'arrêt	1	Get1250MW401-122.127
45	4280 076 01	Sicherungsring 130x4 DIN 471 locking ring/ circlip extérieur	1	
46	7462 221 01	Lager DIN 720 Nr.32021X bearing/palier	2	
*47	9380 466 01	Welle 3 komplett shaft 3 cpl./arbre 3 cpl.	1	Get1250MW421-123.000
48	9380 469 01	Typenschild type plate plaque signalétique	1	Get1250MW421-201.000
49	4315 001 01	Kerbnagel 2x3 DIN 1476 notched nail/ clou conique	4	

Welle 3 komplett
Shaft 3 cpl./Arbre 3 cpl.

pl.

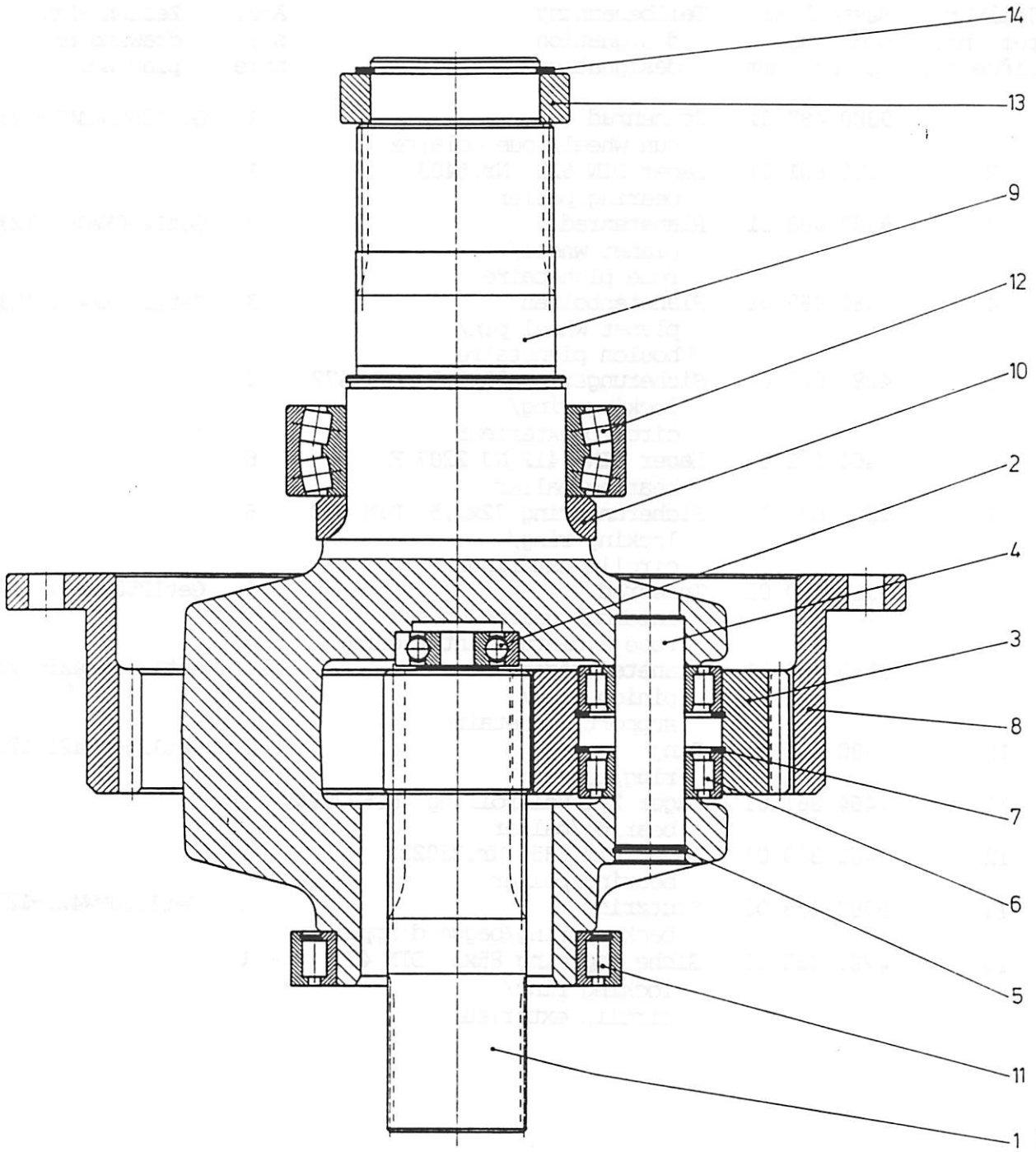

Welle 3 komplett

Shaft 3 cpl./Arbre 3 cpl.

Bestell-Nr. : 9380 466 01
order no.
no. de comm.

Zeichn.-Nr. : Get 1250 MW 421 - 123.000
drawing no.
plan no.

bestehend aus:
consist. of
compose de

Teil-Nr. part no. pièce no.	Bestell-Nr. order no. no. de comm.	Teilbenennung designation désignation	Anz. qty. nbre	Zeichn.-Nr. drawing no. plan no.
1	9380 487 01	Sonnenrad sun wheel/roue solaire	1	Get1250MW401-123.101
2	7451 801 01	Lager DIN 625 Nr.6403 bearing/palier	1	
3	9380 488 01	Planetenrad planet wheel/ roue planetaire	3	Get1250MW401-123.201
4	9380 489 01	Planetenbolzen planet wheel pin/ boulon planetaire	3	Get1250MW401-123.211
5	4281 009 01	Sicherungsring 35x1,5 DIN 472 locking ring/ circlip extérieur	3	
6	7464 121 01	Lager DIN 5412 NJ 2207 E bearing/palier	6	
7	4281 023 01	Sicherungsring 72x2,5 DIN 472 locking ring/ circlip extérieur	6	
8	9380 490 01	Innenrad internal geared wheel/ roue à denture interieure	1	Get1250MW401-123.301
9	9380 467 01	Planetenträger pinion cage/ support planetaire	1	Get1250MW421-123.311
10	9380 464 01	Ring ring/bague	1	Get1250MW421-123.321
11	7464 861 01	Lager Zyl-Vollrolling NCF 2924V bearing/palier	1	
12	7461 300 01	Lager DIN 635 Nr.23022 bearing/palier	1	
13	9380 468 01	Stützring back-up ring/bague d'appui	1	Get1250MW421-123.341
14	4280 063 01	Sicherungsring 85x3 DIN 471 locking ring/ circlip extérieur	1	

Seiltrommel komplett

Rope drum cpl./Tambour de câble cpl.

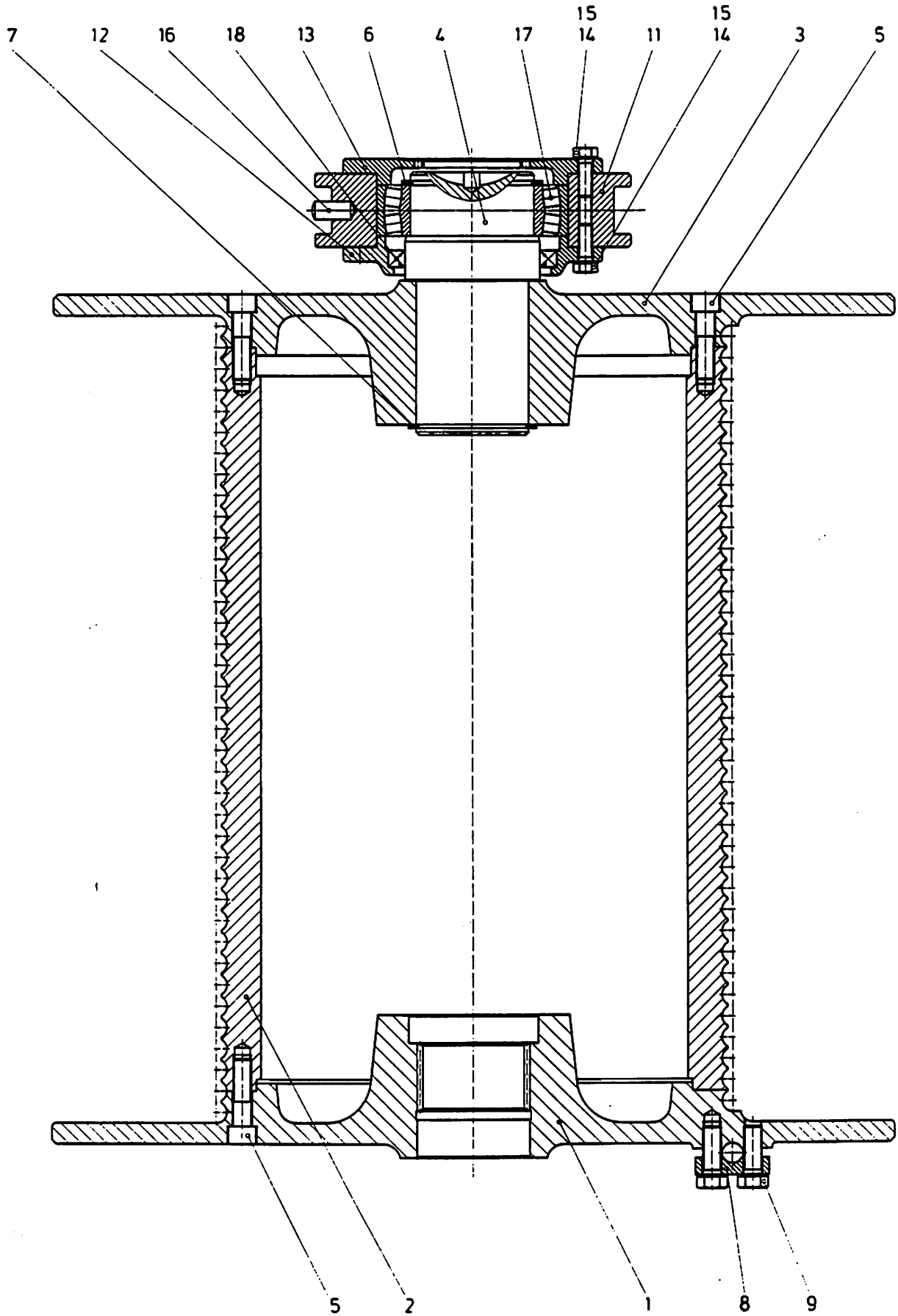

Seiltrommel komplett

Rope drum cpl./Tambour de câble cpl.

Bestell-Nr. : 9943 082 01
order no.
no. de comm.

Zeichn.-Nr. : WiW 260 JX 421 - 742.000
drawing no.
plan no.

bestehend aus:
consist. of
compose de

Teil-Nr. part no. pièce no.	Bestell-Nr. order no. no. de comm.	Teilbenennung designation désignation	Anz. qty. nbre	Zeichn.-Nr. drawing no. plan no.
1	9943 084 01	Endscheibe limit washer/rondelle finale	1	WiW260JX421-742.111
2	9943 030 01	Trommel drum/tambour	1	WiW260JX401-742.112
3	9943 031 01	Endscheibe limit washer/rondelle finale	1	WiW260JX401-742.113
4	9943 032 01	Zapfen journal/tourillon	1	WiW260JX401-742.114
5	4043 173 01	Schraube M 16x60 DIN 912 bolt/vis	32	
6	4280 071 01	Sicherungsring 110x4 DIN 471 locking ring/circlip extérieur	1	
7	4280 067 01	Sicherungsring 100x3 DIN 471 locking ring/circlip extérieur	1	
8	9941 803 01	Klemmstück clamp piece/pièce de serrage	5	WiW240RX052-742.111
9	4065 163 01	Schraube M 16x45 DIN 933-8.8 bolt/vis	10	
10	4239 020 01	Sicherungsscheibe VS 16 lock washer/rondelle d'arrêt	10	
11	9943 034 01	Lagergehäuse bearing housing/carter de palier	1	WiW260JX401-742.211
12	9380 480 01	Deckel cover/couvercle	1	Get1250MW401-112.131
13	9943 035 01	Deckel cover/couvercle	1	WiW260JX401-742.213
14	4065 130 01	Schraube M 12x35 DIN 933-8.8 bolt/vis	16	
15	4239 017 01	Sicherungsscheibe VS 12 lock washer/rondelle d'arrêt	16	
16	4306 141 01	Zylinderstift 16 _{m6} x32 DIN 7 straight pin/ goupille cylindrique	1	
17	7461 300 01	Lager Nr. 23022 DIN 635 bearing/palier	1	
18	7100 310 01	Wellendichtring 120x150x15 BASL DIN 3760-NB rotary shaft seal/ bague à levres avec ressort	1	

Bremse
Brake/Frein

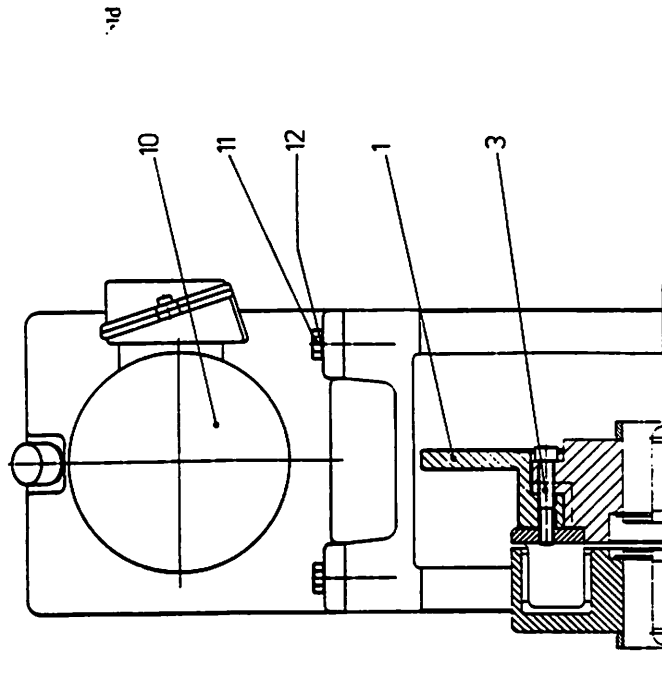

Öleinfüllmenge: 5,0 l
oil quantity/
quantité d'huile

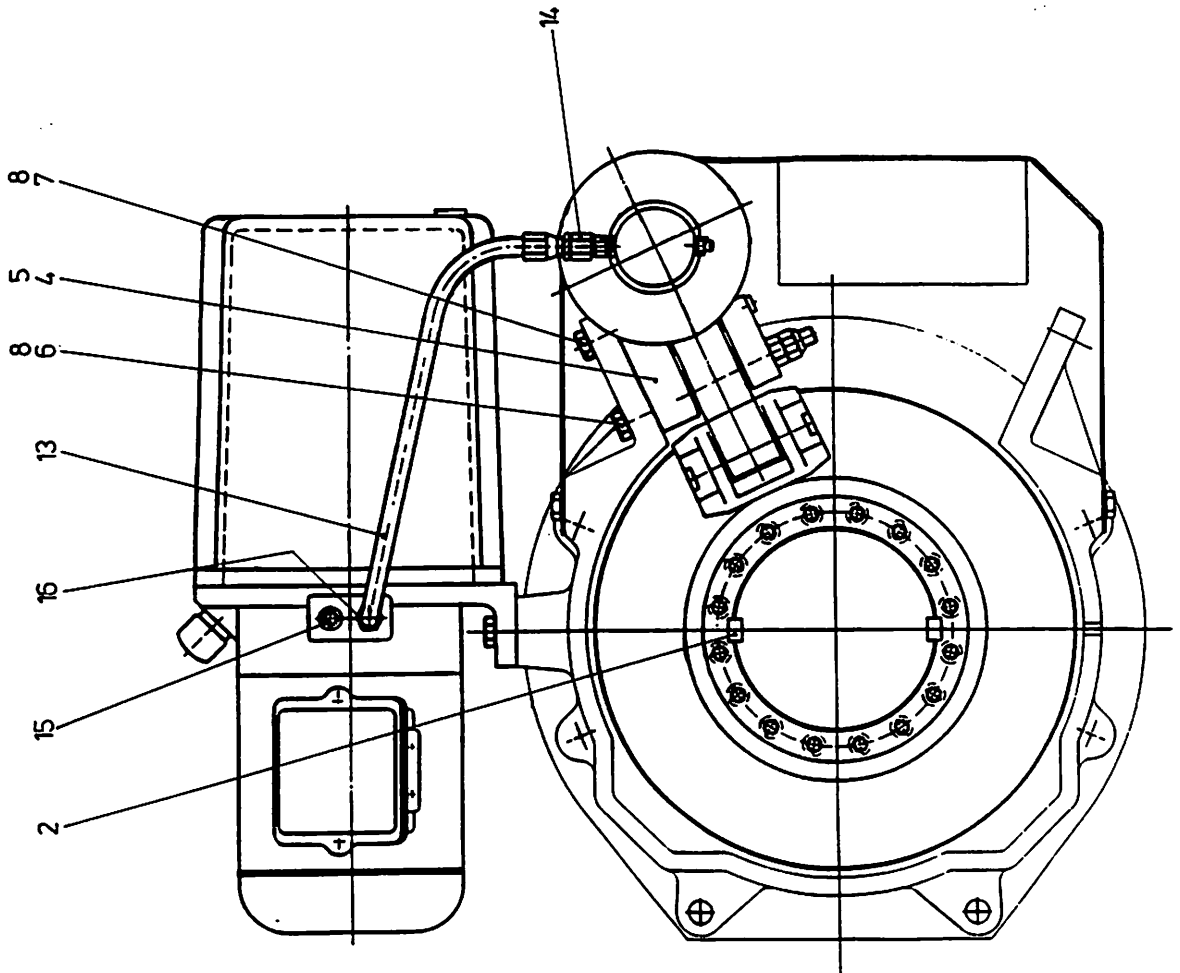

Bremse

Brake/Frein

Bestell-Nr. : 9713 810 01
order no.
no. de comm.

Zeichn.-Nr. : Bre 1650 BY 401 - 100.000
drawing no.
plan no.

bestehend aus :
consist. of
compose de

Teil-Nr. part no. pièce no.	Bestell-Nr. order no. no. de comm.	Teilbenennung designation désignation	Anz. qty. nbre	Zeichn.-Nr. drawing no. plan no.
1	9715 141 01	Bremsscheibe brake disc/disque à frein	1	BRE2500BY401-100.101
2	4341 279 01	Paßfeder AB 16x10x32 DIN 6885 feather key/ clavette parallèle fixée par vis	2	
3	4043 097 01	Schraube M 10x60 DIN 912-10.9 bolt/vis	16	
*4	5029 047 01	Bremszange Typ MX15 SHS brake clamp/pince-freinage	1	
5	5029 050 01	Bremsklotz brake block/cale de freinage	2	
6	4062 022 01	Schraube M 12x150 DIN 931-10.9 bolt/vis	2	
7	4062 020 01	Schraube M 12x60 DIN 931-10.9 bolt/vis	1	
8	4115 048 01	Mutter M 12 DIN 943-10 nut/écrou	3	
9	4119 008 01	Mutter M 12 DIN 982-8 nut/écrou	3	
*10	5100 188 01	Hydraulikaggregat hydraulic aggregate/ groupe hydraulique	1	
11	4065 130 01	Schraube M 12x35 DIN 933-8.8 bolt/vis	2	
12	4239 017 01	Sicherungsscheibe VS 12 lock washer/rondelle d'arrêt	2	
13	9914 149 01	Schlauch hose/tuyau	1	SHL05HP260-000.450
14	4710 160 01	Verschraubung threaded union/vissage	1	
15	4775 105 01	Verschlusschraube screw plug/vis de fermeture	1	
16	4710 180 01	Verschraubung threaded union/vissage	1	

Bremszange links

Brake clamp left/Pince-freinage à gauche

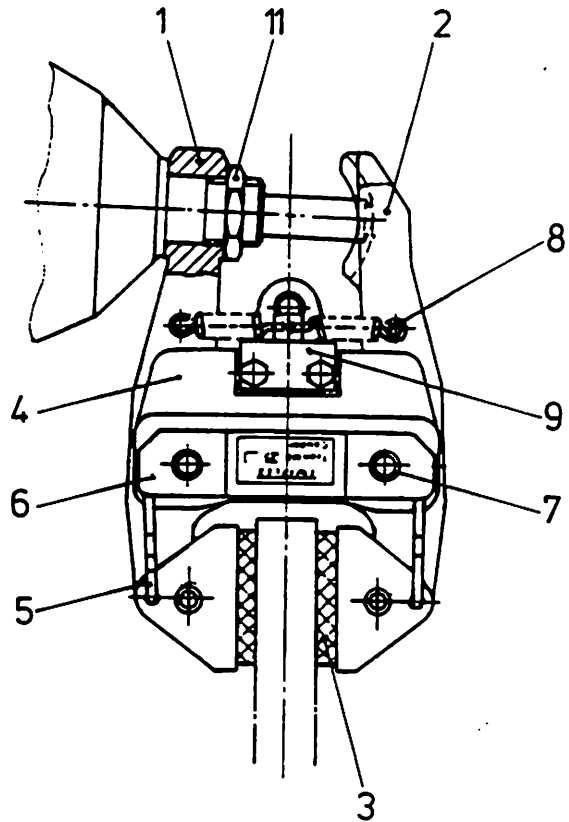
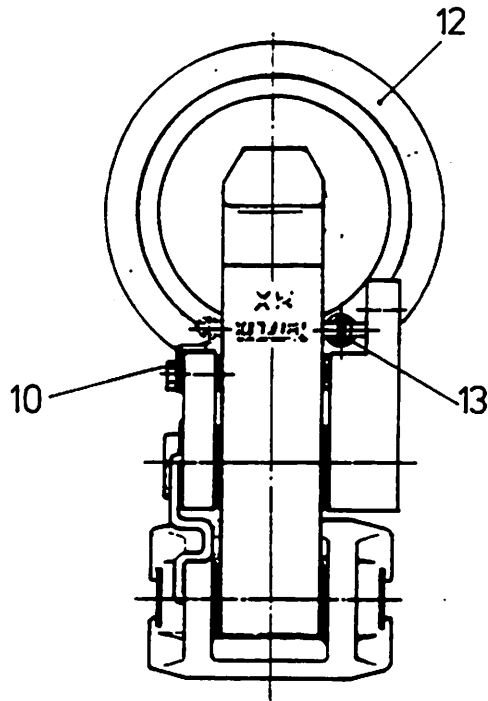

Bestell-Nr. : 5029 048 01
 order no.
 no. de comm.

Typ : MX 15 SHS
 type
 type

bestehend aus:
 consist. of
 compose de

Teil-Nr. part no. pièce no.	Bestell-Nr. order no. no. de comm.	Teilbenennung designation désignation	Anz. qty. nbre	Zeichn.-Nr. drawing no. plan no.
1		Bremshebel mit Loch brake lever with hole/ levier de frein à trou	1	10934
2		Bremshebel ohne Loch brake lever without hole/ levier de frein sans trou	1	10935
3		Bremsbelag brake lining/garniture de frein	2	10808
4		Gehäuse housing/carter	1	10938
5		Parallellenker parallel guide lever/ levier de guidage parallèle	2	10939

Teil-Nr. part no. pièce no.	Bestell-Nr. order no. no. de comm.	Teilbenennung designation désignation	Anz. qty. nbre	Zeichn.-Nr. drawing no. plan no.
6		Deckplatte cover plate/ plaque de recouvrement	1	10940
7		Lagerbuchse bearing bush/douille de palier	2	10941
8		Rückstellfeder return spring/ressort de rappel	2	10883
9		Ankerblech anchor plate/plaque d'ancre	1	10942
10		Sechskantschraube M 6x10 DIN 931 hexagon bolt/vis hexagonale	2	
11		Sechskantmutter hexagon nut/écrou hexagonale	2	10319
*12	5029 055 01	Bremszylinder komplett brake cylinder/cylindre de frein	1	10902
13		Rückstellfeder return busch/douille de palier	2	10270

Bremszylinder komplett , Typ : MX 15 SHS
 Brake cylinder cpl./Cylindre de frein cpl.

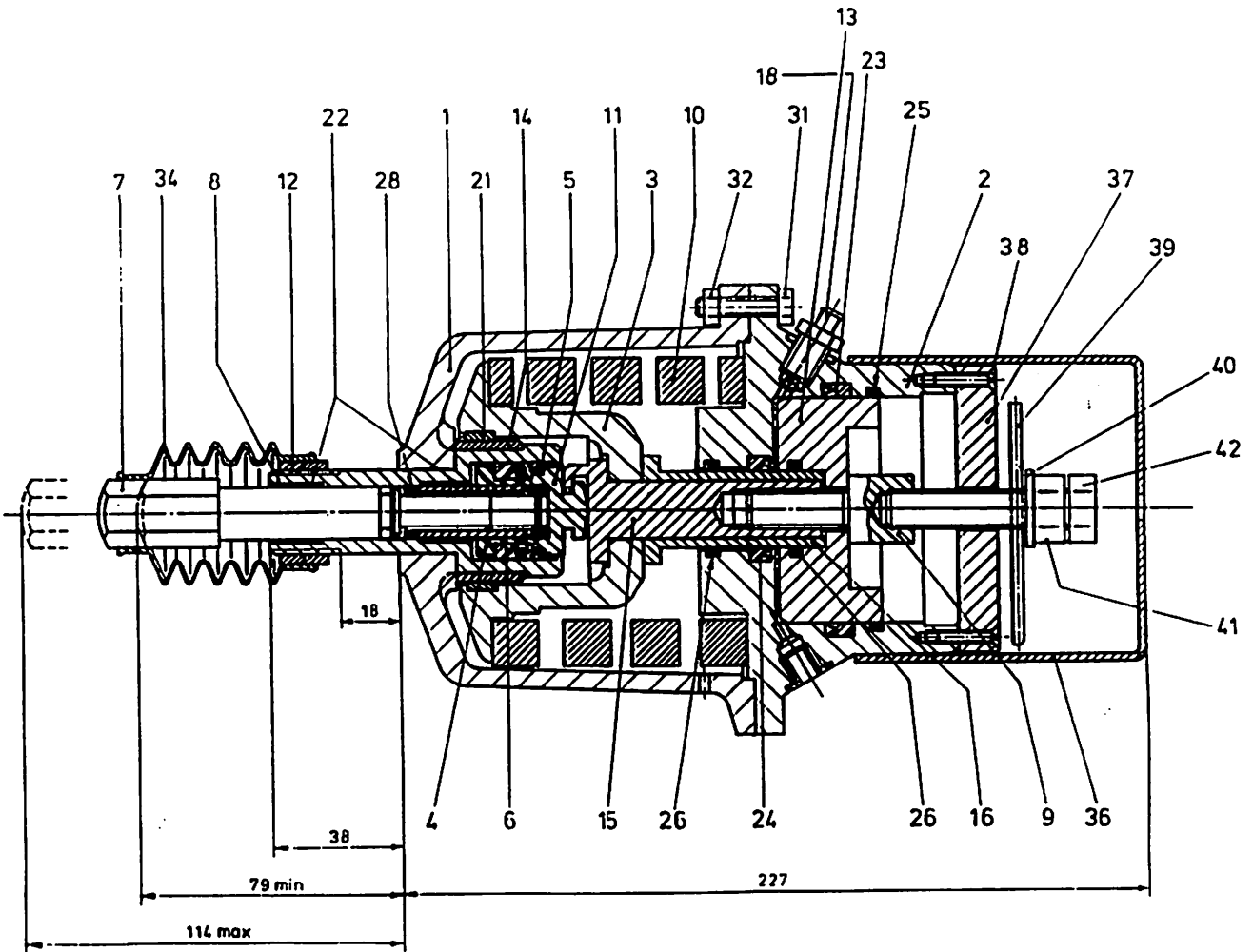

Bestell-Nr. : 5029 055 01
 order no.
 no. de comm.

Zeichn.-Nr. : 10 902
 drawing no.
 plan no.

bestehend aus:
 consist. of
 compose de

Teil-Nr. part no. pièce no.	Bestell-Nr. order no. no. de comm.	Teilbenennung designation désignation	Anz. qty. nbre	Zeichn.-Nr. drawing no. plan no.
12		Sechskantmutter hexagon nut/écrou hexagonale	2	10 319
18		Entlüftungsschraube vent screw/vis de purge d'air	1	10 296
34		Faltenbalg bellows/soufflet	1	10 946
36		Endkappe final cap/chapeau de finissage	1	10 980
39		Stecksicherung plug safety device/ plaquette d'arrêt à fiches	1	11 044

Hydraulikaggregat
Hydraulic aggregate/Groupe hydraulique

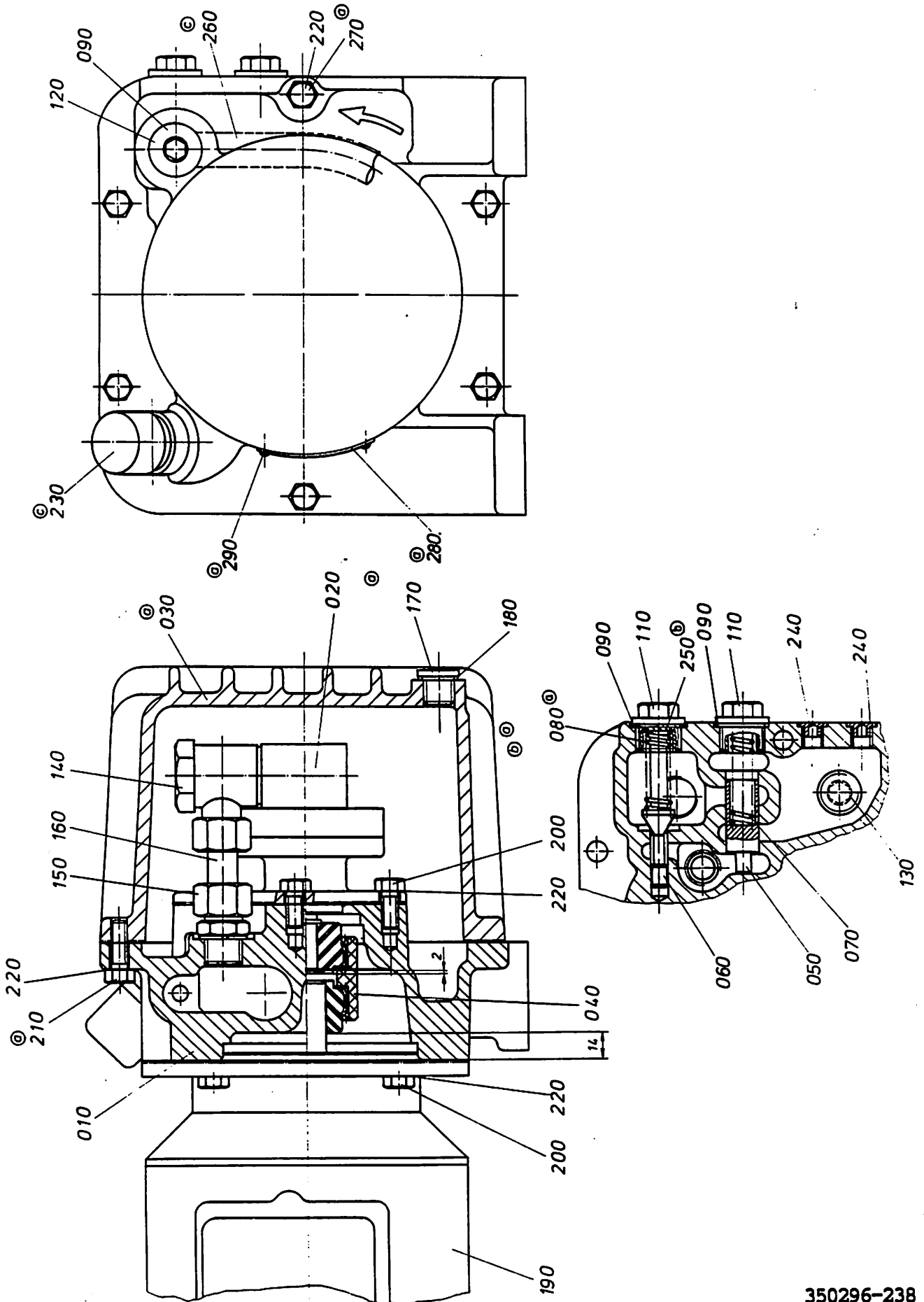

Hydraulikaggregat

Hydraulic aggregate/Groupe hydraulique

Bestell-Nr. : 5100 188 01
order no.
no. de comm.

Zeichn.-Nr. : 350296-238
drawing no.
plan no.

bestehend aus:
consist. of
compose de

Teil-Nr. part no. pièce no.	Bestell-Nr. order no. no. de comm.	Teilbenennung designation désignation	Anz. qty. nbre	Zeichn.-Nr. drawing no. plan no.
010		Flansch flange/ bride	1	350296-232 959504
020		Innenzahnradpumpe internal geared wheel pump/ pompe à roue à denture intérieure	1	6.33001.0120 588289
030		Ölbehälter oil tank/ réservoir à huile	1	350296-240 959876
040		Kupplung M24.19.12 clutch/ embrayage	1	6.33001.0120 598501
050		Steuerkolben 350296-234 piston valve/ piston pilote	1	6.33001.0025 598509
060		Überdruckkolben 350296-235 pressure relief piston/ piston de surpression	1	6.33001.0025 598510
070		Druckfeder D 263 V-06 pressure spring/ ressort de ou à pression	1	6.33001.0006 598508
080		Druckfeder VD 288 T-06 pressure spring ressort de ou à pression	1	6.33001.0006 598542
090	7101 045 01	Dichtring A 22x27 DIN 7603-Cu sealing ring/ bague d'étanchéité	3	6.33001.0005 584898
110		Verschlußschraube screw plug/ vis de fermeture	2	350296-237 959494
120	4041 006 01	Verschlußschraube M 22x1,5 DIN 908-5.8 screw plug/ vis de fermeture	1	6.33001.0001 579777
130	4039 006 01	Verschlußschraube M 22x1,5 DIN 906-5.8 screw plug/ vis de fermeture	1	6.33001.0001 598506
140		Schwenkverschraubung WHO 15-PLM swivelling screw-fitting/ raccord fileté orientable	1	6.33001.0026 598504
150		Gerade Einschraubverschraubung GE 15-PLM M 18x1,5 straight screwing-fitting/ raccord fileté droit	1	6.33001.0026 598505

Teil-Nr. part no. pièce no.	Bestell-Nr. order no. no. de comm.	Teilbenennung designation désignation	Anz. qty. nbre	Zeichn.-Nr. drawing no. plan no.
160		Rohr 350296-236 tube/ tuyau	1	6.33001.0046 598511
170	4041 004 01	Verschlußschraube M 16x1,5 DIN 908-5.8 screw plug/ vis de fermeture	1	6.33001.0001 578532
180	7101 034 01	Dichtring A 16x20 DIN 7603-Cu sealing ring/ bague d'étanchéité	1	6.33001.0005 578561
190		E-Motor 1.1 kW BG 80 380/220V electric motor/ moteur électrique	1	6.33001.0103 598503
200	4065 069 01	Sechskantschraube M 8x20 DIN 933-8.8 hexagon screw/ vis hexagonale	8	6.33001.0001 586485
210	4065 073 01	Sechskantschraube M 8x30 DIN 933-8.8 hexagon screw/ vis hexagonale	5	6.33001.0001 598541
220		Sicherung M 8 safety device/ dispositif de sécurité	14	6.33001.0004 577232
230		Belüftungsfilter L 1.0406-74 ventilating filter/ filtre de ventilation	1	6.33001.0120 598562
240		Verschlußstopfen F 4 vent plug/ bouchon de fermeture	2	6.33001.0005 583077
250		Paßscheibe PS 9x15x0,5 DIN 988-St shim ring/ rondelle à juste	1	6.33001.0004 598556
260		Rohr 350296-241 tube/ tuyau	1	6.33001.0046 598559
270	4065 079 01	Sechskantschraube M 8x60 DIN 933-8.8 hexagon screw/ vis hexagonale	1	6.33001.0001 590044
280		Typenschild 351059-135 type plate/ plaque signalétique	1	6.33001.0121 585130

Spindelenschalter

Rotating limit switch/Interrupteur de fin de course de tige

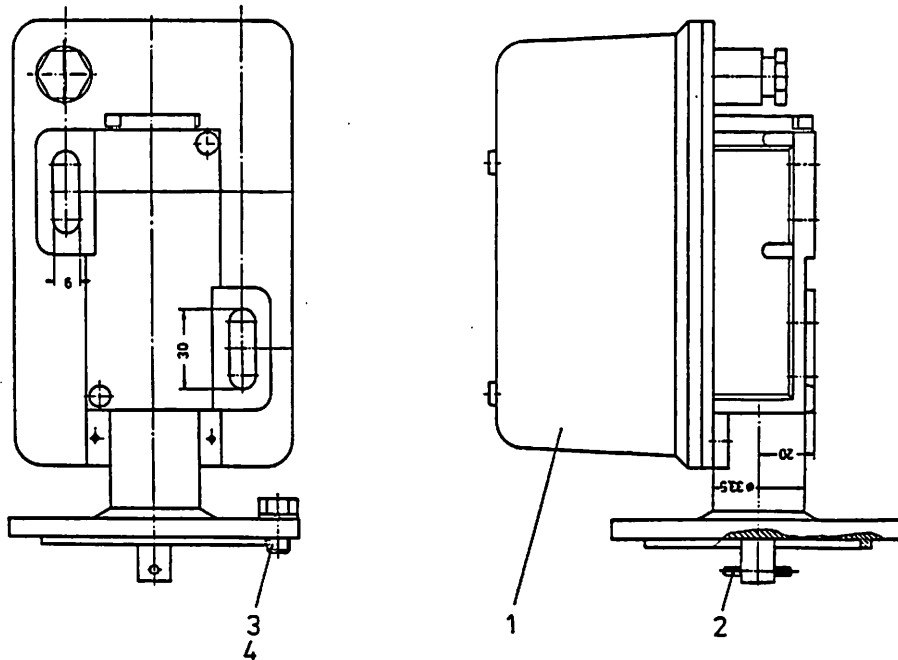

Bestell-Nr. : 9956 639 01
order no.
no. de comm.

Zeichn.-Nr. : WiW 240 RX 025 - 748.000
drawing no.
plan no.

bestehend aus:
consist. of
compose de

Teil-Nr. part no. pièce no.	Bestell-Nr. order no. no. de comm.	Teilbenennung designation désignation	Anz. qty. nbre	Zeichn.-Nr. drawing no. plan no.
1	6060 249 01	Getriebeendschalter transmission limit switch/ interrupteur de fin de course de l'engrenage	1	
***	6060 261 01	Getriebeendschalter transmission limit switch/ interrupteur de fin de course de l'engrenage	1	
***	6351 121 01	Potentiometer potentiometer/potentiomètre	1	
2	4312 007 01	Kerbstift 3x24 DIN 1473 grooved pin/goupille cannelée	1	
3	4065 067 01	Schraube M 8x16 DIN 933-8.8 bolt/vis	3	
4	4240 007 01	Federring A 8 DIN 127 spring washer/rondelle grower	3	

*** Nur wenn eine Hubhöhenanzeige vorhanden
Only if a hoist height indicator is installed/
Seulement si un indicateur de hauteur de levage est installé

E-Motor

Electric motor/Moteur électrique

Bestell-Nr. : 6101 808 01

Stüchl.-Nr.: E 20.0930 - 000/204

list no.

no. liste

Zeichn.-Nr. : E 20.0930 C 000/124

drawing no.

order no.

no. de comm.

plan no.

bestehend aus:

consist. of

compose de

Teil-Nr. part no. pièce no.	Bestell-Nr. order no. no. de comm.	Teilbenennung designation désignation	Anz. qty. nbre	Zeichn.-Nr. drawing no. plan no.
103	9756 844 01	Stator komplett, mit Teile Nr. 115-365 stator cpl., with part no.115-365/ stator cpl., avec pièce no.115-365	1	E20.0930-802/001
115	9756 848 01	Stator gewickelt stator taped/stator rubané	1	E20.0930-702/001
131	4021 593 01	Gewindestift M 12x20 DIN 553 set screw/vis sans tête	2	
150	9756 831 01	Gehäuse housing/carter	1	E20.0930C113/001
304	6027 011 01	Kabeltülle KT 21 cable bushing/ douille de câble	6	
305	6230 010 01	Klemmbrett tagboard/planches à bornes	1	IN E93.850/12
306	4001 058 01	Schraube M 6x20 DIN 84-5.8 bolt/vis	2	
307	4200 508 01	Scheibe 13 DIN 125-Ms washer/rondelle	12	
308	4115 509 01	Mutter M 12 DIN 934-Ms nut/écrou	6	
310	9939 125 01	Klemmbrett komplett tagboard cpl./ planches à bornes cpl.	1	E00.0000G640/008
311	4001 058 01	Schraube M 6x20 DIN 84-5.8 bolt/vis	2	
312	4200 508 01	Scheibe 13 DIN 125-Ms washer/rondelle	6	
313	4115 509 01	Mutter M 12 DIN 934-Ms nut/écrou	3	
315	6250 013 01	Erdungszeichen grounding sign/ signe de terre	1	E00.0000G636/006
316	4200 508 01	Scheibe 13 DIN 125-Ms washer/rondelle	2	
317	4067 019 01	Schraube M 12x20 DIN 933-Ms bolt/vis	1	
320	9756 762 01	Klemmkasten-Unterteil terminal box under part/ bas de la boîte de bornes	1	E00.0238D601/138

Teil-Nr. part no. pièce no.	Bestell-Nr. order no. no. de comm.	Teilbenennung designation désignation	Anz. qty. nbre	Zeichn.-Nr. drawing no. plan no.
321	4065 069 01	Schraube M 8x20 DIN 933-8.8 bolt/vis	4	
322	4239 014 01	Sicherungsscheibe VS 8 lock washer/rondelle d'arrêt	4	
323	6025 002 01	Blindstopfen PG 11 dummy plug/faux bouchon	2	LN E92.050/03
335	6230 002 01	Klemmbrett tagboard/planches à bornes	1	LN E93.850/01
336	4001 017 01	Schraube M 4x12 DIN 84-5.8 bolt/vis	2	
342	4200 502 01	Scheibe 4,3 DIN 125-Ms washer/rondelle	18	
343	4115 503 01	Mutter M 4 DIN 934-Ms nut/écrou	12	
344	6231 006 01	Klemmbrett-Verbindung terminal board connection/ connexion de planche à bornes	3	LN E93.860/01
365	9938 899 01	Läuferlitze komplett rotor strand/ toron rotorique	6	E10.1001G646/003
400	9756 845 01	Rotor komplett mit Teile Nr. 405-678 rotor cpl., with part no. 405-678/ rotor cpl., avec pièce no. 405-678	1	E20.0930-910/001
405	9756 857 01	Rotor gewickelt, mit Teil Nr.453-555 rotor taped, with part no. 453-555/ rotor rubané, avec pièce no. 453-555	1	E20.0930-920/001
453	4340 372 01	Paßfeder A 22x14x220 DIN 6885 feather key/ clavette parallèle fixée par vis	1	
454	4280 063 01	Sicherungsring 85x3 DIN 471 locking ring/circlip extérieur	1	
500	6210 026 01	Schleifringkörper slip ring unit/ corps de bague collectrice	1	
550	9756 839 01	Lüfterrad fan/ventilateur	1	E20.0900E504/003
555	4065 022 01	Schraube M 5x12 DIN 933-8.8 bolt/vis	3	
650	9756 838 01	Lüfterrad fan/ventilateur	1	E20.0900E504/002
675	4342 152 01	Paßfeder B 18x11x40 DIN 6885 feather key/ clavette parallèle fixée par vis	1	
676	4340 273 01	Paßfeder A 18x11x80 DIN 6885 feather key/ clavette parallèle fixée par vis	1	
678	4280 049 01	Sicherungsring 60x2 DIN 471 locking ring/ circlip extérieur	1	

Teil-Nr. part no. pièce no.	Bestell-Nr. order no. no. de comm.	Teilbenennung designation désignation	Anz. qty. nbre	Zeichn.-Nr. drawing no. plan no.
705	9756 835 01	Flanschlagerschild flange bearing plate/ flasque bride	1	E20.0900D403/001
706	4042 129 01	Schraube M 12x90 DIN 912-8.8 bolt/vis	8	
707	4239 017 01	Sicherungsscheibe VS 12 lock washer/rondelle d'arrêt	8	
710	7451 638 01	Lager DIN 625 Nr.6313 bearing/palier	1	
715	9756 873 01	Lagerdeckel cap piece of the bearing/ chapeau de palier	2	E00.0140E421/106
717	7208 051 01	Tellerfeder 139x90,5x1,25 K 6313 cup spring/ ressort belleville	2	
718	4042 074 01	Schraube M 8x65 DIN 912-8.8 bolt/vis	6	
719	4239 014 01	Sicherungsscheibe VS 8 lock washer/rondelle d'arrêt	6	
720	7109 402 01	Dichtring WVA-0075 V65B conical nipple/ bague d'étanchéité	2	
721	9756 874 01	Distanzbuchse distance bush/ douille d'écartement	1	E00.0065F314/095
722	4220 133 01	Stützscheibe 65x85x3,5 DIN 988 supporting ring/ rondelle pour bague de frein	1	
723	4280 052 01	Sicherungsring 65x2,5 DIN 471 locking ring/circlip extérieur	1	
736	9756 887 01	Gewinding ring follower/bague filetée	1	E04.4200F138/001
737	4042 065 01	Schraube M 8x25 DIN 912-8.8 bolt/vis	5	
738	4239 014 01	Sicherungsscheibe VS 8 lock washer/rondelle d'arrêt	5	
755	9756 836 01	Lagerschild bearing plate/flasque	1	E20.0900D402/003
756	4042 118 01	Schraube M 12x35 DIN 912-8.8 bolt/vis	8	
757	4239 017 01	Sicherungsscheibe VS 12 lock washer/rondelle d'arrêt	8	
760	7452 313 01	Lager DIN 628 Nr.7213 B Typ UO bearing/palier	2	
765	9756 876 01	Lagerdeckel cap piece of the bearing/ chapeau de palier	2	E00.0120E421/107
768	4065 073 01	Schraube M 8x30 DIN 933-8.8 bolt/vis	12	
769	4239 014 01	Sicherungsscheibe VS 8 lock washer/rondelle d'arrêt	12	
770	7109 402 01	Dichtring WVA-0075 V65B conical nipple/ bague d'étanchéité	2	

Teil-Nr. part no. pièce no.	Bestell-Nr. order no. no. de comm.	Teilbenennung designation désignation	Anz. qty. nbre	Zeichn.-Nr. drawing no. plan no.
771	9756 875 01	Distanzbuchse distance bush/ douille d'écartement	1	E00.0065F314/096
772	4220 133 01	Stützscheibe 65x85x3,5 DIN 988 supporting ring/ rondelle pour bague de frein	1	
773	7472 206 01	Sicherungsblech MB 13 safety plate/tôle d'arrêt	1	
774	7472 008 01	Nutmutter KM 13 M 65x2 slotted nut/écrou rainuré	1	
775	9756 965 01	Fensterabdeckung window covering/ couverture de fenêtre	2	E00.0000D416/207
776	4042 039 01	Schraube M 6x16 DIN 912-8.8 bolt/vis	8	
777	4239 011 01	Sicherungsscheibe VS 6 lock washer/rondelle d'arrêt	8	
810	9756 786 01	Klemmkasten-Oberteil terminal box upper part/ partie supérieure de la boîte	1	E00.0238D610/067
811	4042 065 01	Schraube M 8x25 DIN 912-8.8 bolt/vis	2	
812	4042 077 01	Schraube M 8x80 DIN 912-8.8 bolt/vis	2	
813	4239 014 01	Sicherungsscheibe VS 8 lock washer/rondelle d'arrêt	4	
815	6231 005 01	Klembrett-Verbindung terminal board connection/ connexion de planche à bornes	3	IN E93.861/11
816	4200 508 01	Scheibe 13 DIN 125-Ms washer/rondelle	6	
817	4115 509 01	Mutter M 12 DIN 934-Ms nut/écrou	6	
830	9756 787 01	Klemmstück clamp piece/ pièce de serrage	1	E00.0000E611/018
831	4042 068 01	Schraube M 8x35 DIN 912-8.8 bolt/vis	2	
832	4239 014 01	Sicherungsscheibe VS 8 lock washer/rondelle d'arrêt	2	
835	9756 878 01	Kupplungsflansch coupling flange/ bride d'accouplement	1	E00.0000F344/065
836	4042 018 01	Schraube M 5x16 DIN 912-8.8 bolt/vis	2	
837	4239 010 01	Sicherungsscheibe VS 5 lock washer/rondelle d'arrêt	2	
838	5020 067 01	Bremswächter Typ ALNI 5 Nr. 871 09 0 002/9 brake control/ dipositif de protection de frein	1	
839	4307 012 01	Zylinderstift 4 m6 x 24 DIN 6325 2 straight pin/ goupille cylindrique	2	
840	4042 039 01	Schraube M 6x16 DIN 912-8.8 bolt/vis	4	

Teil-Nr. part no. pièce no.	Bestell-Nr. order no. no. de comm.	Teilbenennung designation désignation	Anz. qty. nbre	Zeichn.-Nr. drawing no. plan no.
841	4239 011 01	Sicherungsscheibe VS 6 lock washer/rondelle d'arrêt	4	
860	6250 022 01	Leistungsschild output plate/ plaquette de capacité	1	E00.0000G300/007
861	4315 002 01	Kernnagel 2x4 DIN 1476 notched nail/ clou conique	2	
870	6260 089 01	Fremdlüfter separate fan/ ventilateur separe	1	
871	4042 041 01	Schraube M 6x20 DIN 912-8.8 bolt/vis	4	
872	4239 011 01	Sicherungsscheibe VS 6 lock washer/rondelle d'arrêt	4	
875	9756 879 01	Abdeckhaube covering cap/capot	1	E00.0000D365/022
895	9756 847 01	Bürstenhalter komplett, mit Teile Nr.901-922 brush holder cpl., with part no.901-922/ porte-balai cpl., avec pièce no.901-922	1	E20.0900-650/002
901	6223 037 01	Bürstenhalterbolzen brush holder pin/ tourillon de porte-balai	1	
904	6034 019 01	Isolierscheibe insulating washer/ rondelle isolante	2	
906	4239 020 01	Sicherungsscheibe VS 16 lock washer/rondelle d'arrêt	1	
920	6221 083 01	Doppelbürstenhalter double brush holder/ porte-balai double	3	
922	6220 167 01	Bürste brush/balai	6	LNE93.837/14
*931	6182 072 01	Wirbelstrombremse 4200 eddy current brake/ frein à courants parasites	1	E04.4200 D 000/001
932	4042 093 01	Schraube M 10x40 DIN 912-8.8 bolt/vis	8	
933	4239 015 01	Sicherungsscheibe VS 10 lock washer/rondelle d'arrêt	8	

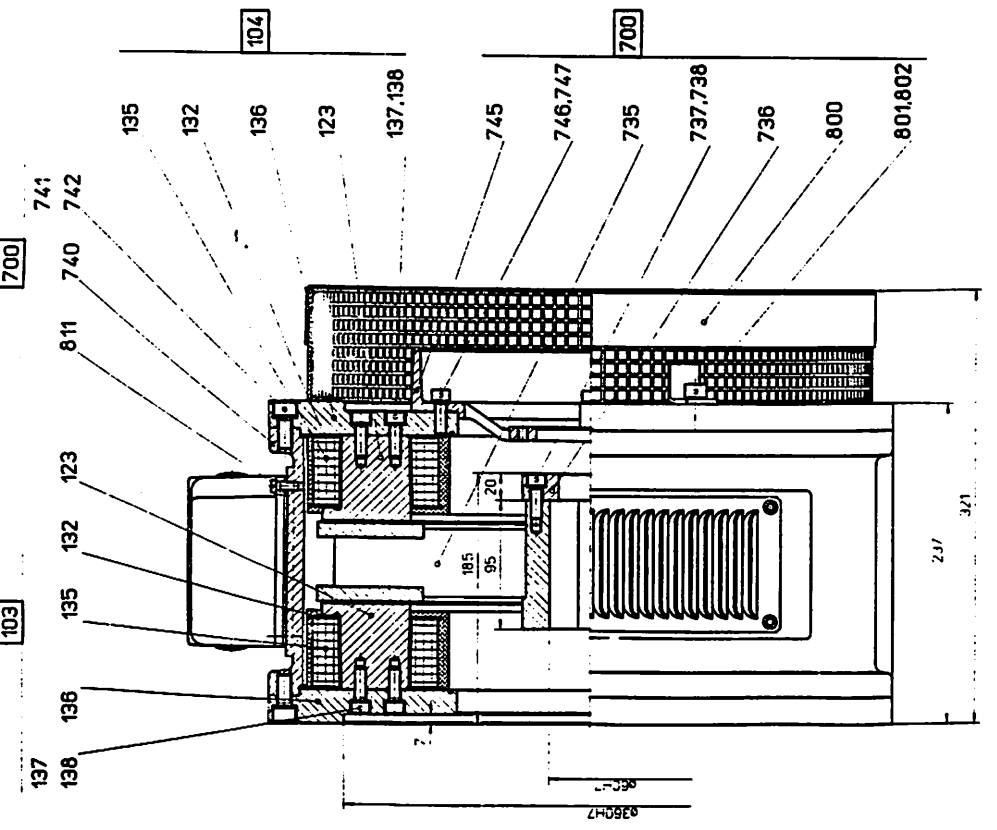
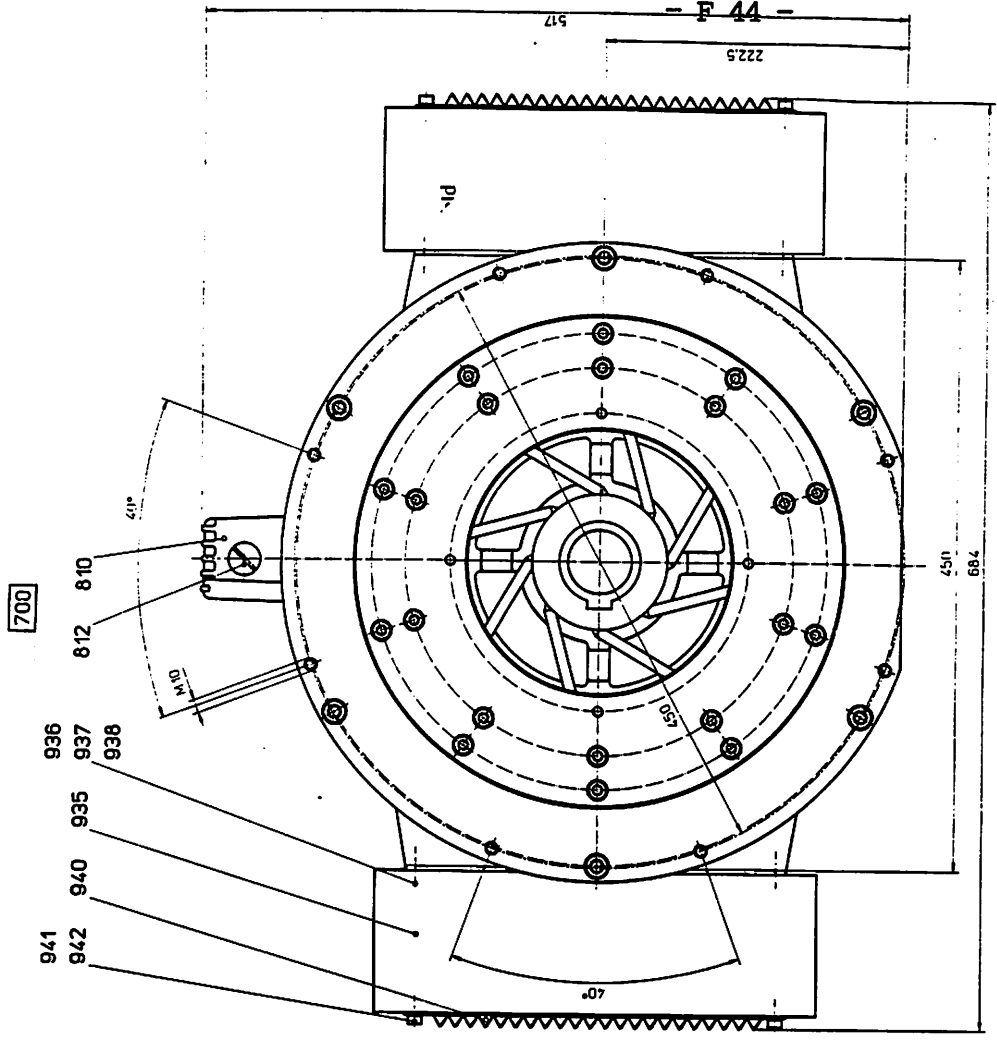

Ohne Klemmkasten-
Oberteil gezeichnet

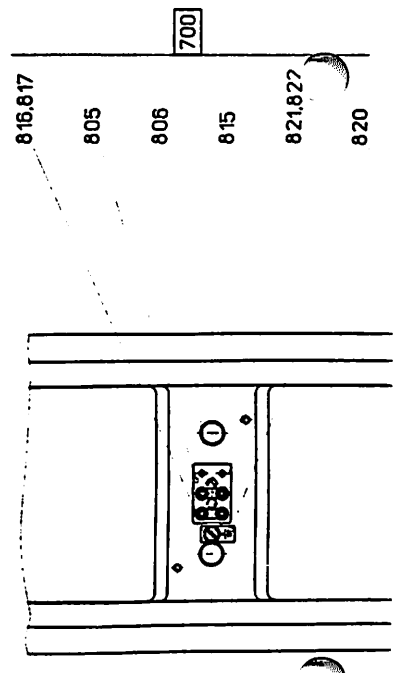

LIEBHERR	
A1	
LBC	
1/1983	
1/1983	
1:2	
Wirbelstrombremse WSB 4200 S 1	

Wirbelstrombremse WSB 4200 S 1 ABA
Eddy-current brake/Frein à courants parasites

Bestell-Nr. : 6182 072 01
order no.
no. de comm.

Stüchl.-Nr. : E 04.4200 - 000/203
list no.
no. liste
Zeichn.-Nr. : E 04.4200 D 000/001
drawing no.
plan no.

bestehend aus:
consist. of
compose de

Teil-Nr. part no. pièce no.	Bestell-Nr. order no. no. de comm.	Teilbenennung designation désignation	Anz. qty. nbre	Zeichn.-Nr. drawing no. plan no.
103	9756 880 01	Jochplatte gewickelt joke plate typed/ plaque de culasse rubané	1	E04.4200-142/000
104	9756 881 01	Jochplatte gewickelt joke plate typed/ plaque de culasse rubané	1	E04.4200-143/000
700	9756 882 01	Montageteile assembly parts/ pièces d'assemblage	1	E04.4200-990/001
735	9756 886 01	Polrad komplett pol wheel/roue polaire	1	E04.4200D141/001
736	9756 887 01	Gewinding threaded ring/bague filetée	1	E04.4200F138/001
737	4042 065 01	Schraube M 8x25 DIN 912-8.8 bolt/vis	5	
738	4239 014 01	Sicherungsscheibe VS 8 lock washer/rondelle d'arrêt	5	
740	9756 837 01	Bremsgehäuse brake housing/carter de frein	1	E04.4200D135/001
741	4042 090 01	Schraube M 10x25 DIN 912-8.8 bolt/vis	12	
742	4239 015 01	Sicherungsscheibe VS 10 lock washer/rondelle d'arrêt	12	
745	9756 841 01	Zwischenflansch intermediate flange/ bride intermediaire	1	E04.4200E408/001
746	4042 065 01	Schraube M 8x25 DIN 912-8.8 bolt/vis	4	
747	4239 014 01	Sicherungsscheibe VS 8 lock washer/rondelle d'arrêt	4	
800	9756 888 01	Schutzdach shed/abri	1	E04.4200E530/001
801	4042 089 01	Schraube M 10x20 DIN 912-8.8 bolt/vis	4	
802	4239 015 01	Sicherungsscheibe VS 10 lock washer/rondelle d'arrêt	4	
805	6230 002 01	Klembrett tagboard/planche à bornes	1	LN E93.850/01
806	4001 016 01	Schraube M 4x10 DIN 84-5.8 bolt/vis	2	

Teil-Nr. part no. pièce no.	Bestell-Nr. order no. no. de comm.	Teilbenennung designation désignation	Anz. qty. nbre	Zeichn.-Nr. drawing no. plan no.
810	9938 266 01	Klemmkasten-Oberteil terminal box upper part/ partie supérieure de la boîte de bornes	1	E00.0000F610/052
811	4001 057 01	Schraube M 6x16 DIN 84-5.8 bolt/vis	2	
812	6025 002 01	Blindstopfen PG 11 dummy plug/bouchon faux	2	LN E92.050/03
815	6231 006 01	Klemmbrett-Verbindung tagboard connection/ attache de planche à bornes	2	LN E93.860/01
816	4200 502 01	Scheibe 4,3 DIN 125-MS washer/rondelle	10	
817	4115 503 01	Mutter M 4 DIN 934-MS nut/écrou	8	
818	6023 085 01	Kabelschuh RSP 7108 cable shoe/patin de câble	4	
820	6250 011 01	Erdungszeichen M 6 grounding sign/signé de terre	1	E00.0000G636/003
821	4002 041 01	Schraube M 6x16 DIN 85-5.8 bolt/vis	1	
822	4200 504 01	Scheibe 6,4 DIN 125-MS washer/rondelle	2	
860	6250 033 01	Leistungsschild output plate/ plaquette de capacité	1	E00.0000G300/012
861	4315 002 01	Kerbnagel 2x4 DIN 1476 notched nail/clou conique	2	
935	9756 883 01	Fensterabdeckung komplett window covering cpl./ couverture de fenêtre cpl.	2	E00.0000E416/200
936	4042 039 01	Schraube M 6x16 DIN 912-8.8 bolt/vis	8	
937	9756 580 01	Scheibe washer/rondelle	8	E00.0000G316/101
938	4218 007 01	Scheibe A 6,4 DIN 9021-St washer/rondelle	8	
940	9756 884 01	Fensterabdeckung window covering/ couverture de fenêtre	2	E00.0000F416/202
941	4042 038 01	Schraube M 6x12 DIN 912-8.8 bolt/vis	4	
942	4239 011 01	Sicherungsscheibe VS 6 lock washer/rondelle d'arrêt	4	