

SCHALTSCHRANK S1
 SWITCHGEAR CABINET / ARMOIRE ÉLECTRIQUE / QUADRO ELETTRICO /
 ARMARIO ELÉCTRICO / РАСПРЕДШКАФ

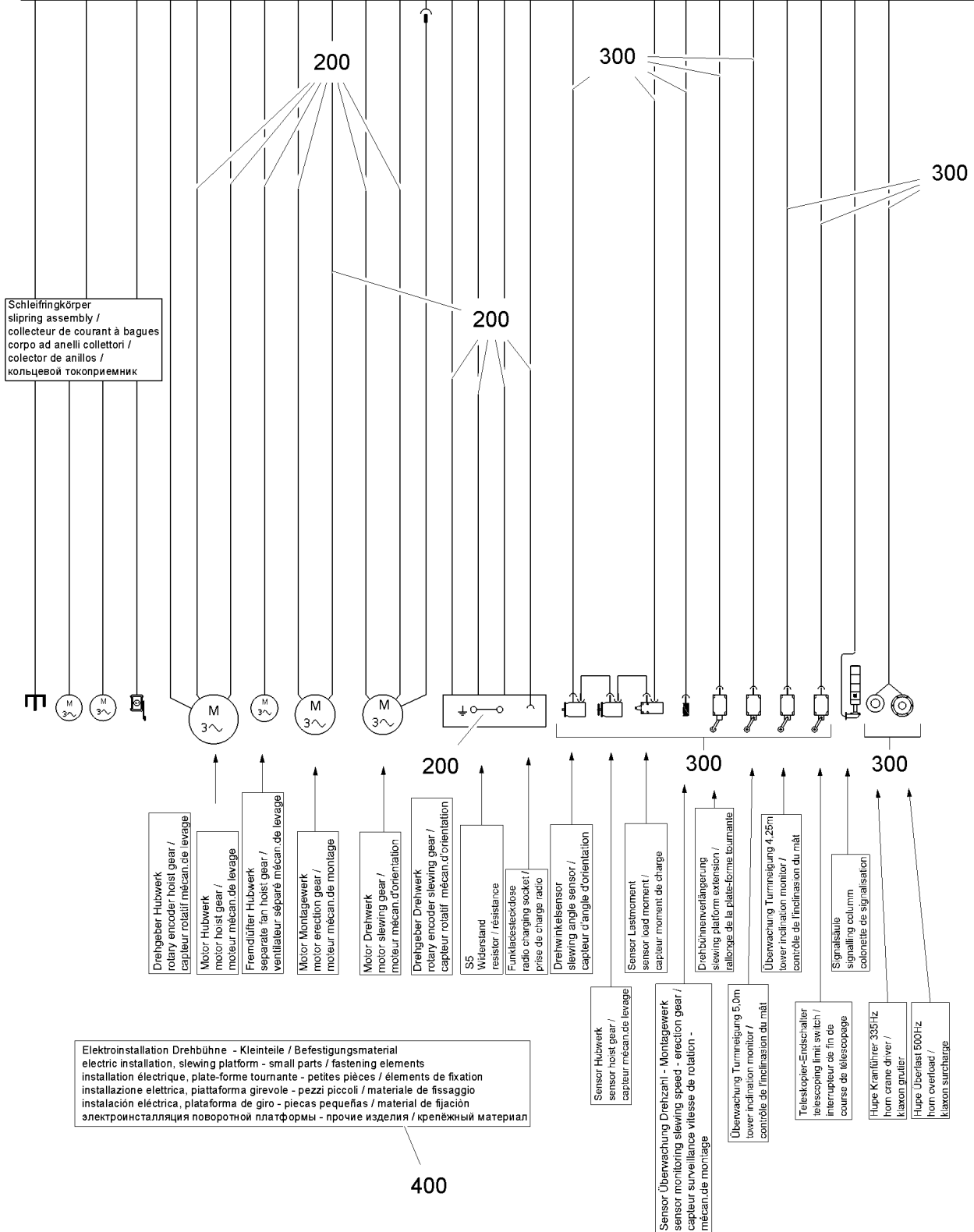

Elektroinstallation Drehbühne 81K
 electric installation, slewing platform
 installation électrique, plate-forme tournante
 installazione elettrica, piattaforma girevole
 instalación eléctrica, plataforma de giro
 электронная установка поворотной платформы

A 120.800 - 411.000 (1.0)

308116

23.4.2012
 308116

LIEBHERR

**GESAMTLISTE
 OVERALL SURVEY
 E-INST. DREHBUEHNE
 EL.INST. SLEWING PLATFORM**

136 (1/2)

90 01 455 6

Pos.	Artikel	Menge	Bezeichnung	Description	Serie
200	90014564	1	E-INST. DREHBUEHNE ⇒  138	EL.INST. SLEWING PLATFORM	
300	90014565	1	E-INST. DREHBUEHNE ⇒  142	EL.INST. SLEWING PLATFORM	
400	90014566	1	E-INST. DREHBUEHNE ⇒  146	EL.INST. SLEWING PLATFORM	

<p>23.4.2012</p> <p>LIEBHERR</p>	<p>GESAMTLISTE OVERALL SURVEY E-INST. DREHBUEHNE EL.INST. SLEWING PLATFORM</p>	<p> 137 (2/2)</p> <p>90 01 455 6</p>
---	--	---

SCHALTSCHRANK S1
 SWITCHGEAR CABINET / ARMOIRE ÉLECTRIQUE / QUADRO ELETTRICO /
 ARMARIO ELÉCTRICO / РАСПРЕДШКАФ

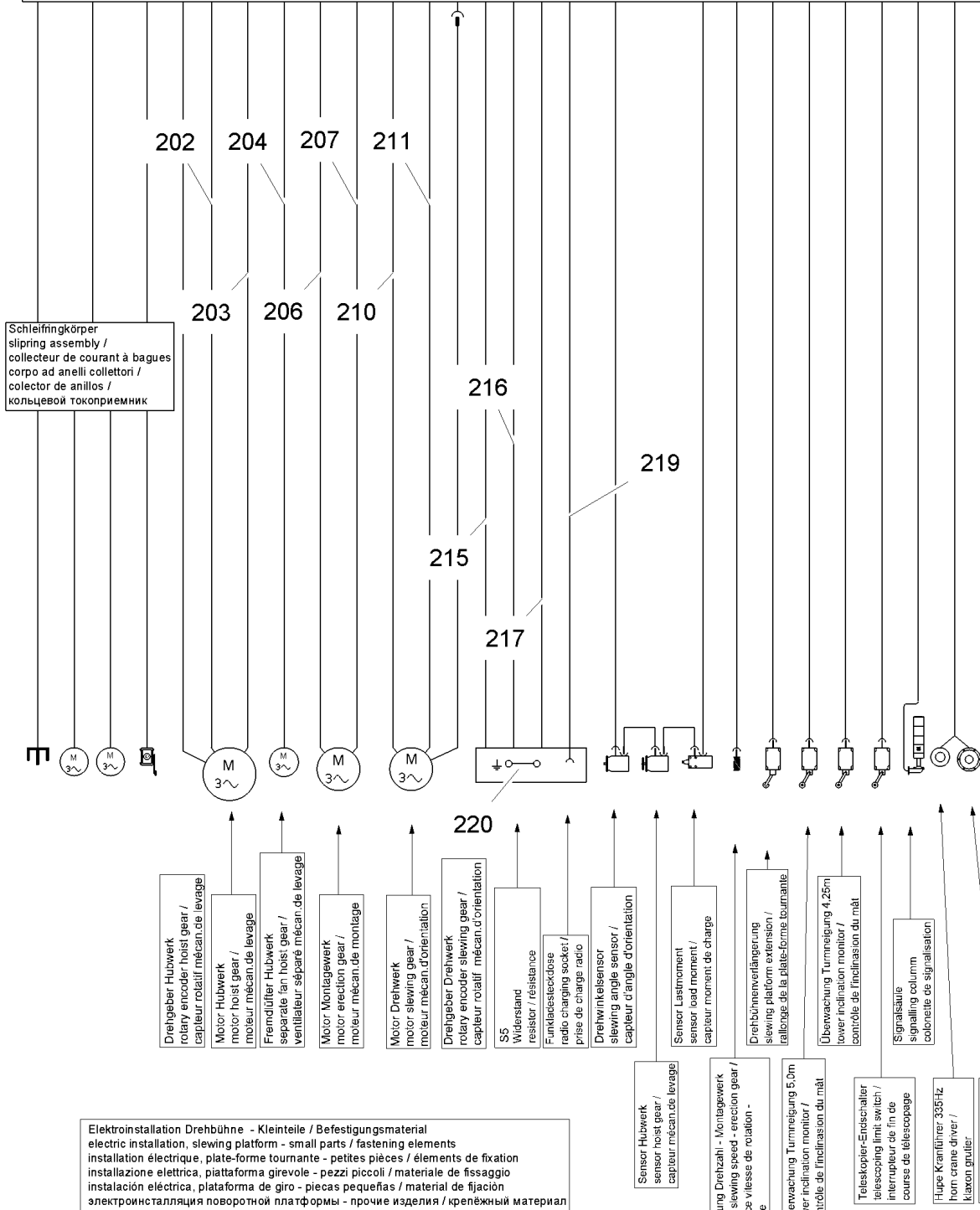

Elektroinstallation Drehbühne 81K -Leitungen

Electric installation, slewing platform - lines
 Installation électrique, plate-forme tournante - lignes
 Installazione elettrica, piattaforma girevole - linee
 Instalación eléctrica, plataforma de giro - líneas
 электронинсталляция поворотной платформы - линии / кабели

A 120.800 - 411.200 / Bl. 1 (1.0)

308117

23.4.2012
 308117

LIEBHERR

**GESAMTLISTE
 OVERALL SURVEY
 E-INST. DREHBUEHNE
 EL.INST. SLEWING PLATFORM**

138 (1/4)

90 01 456 4

= S1
+ H
- T1

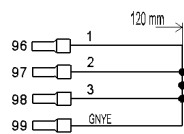

203

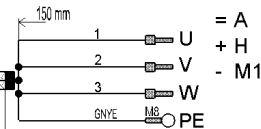

Erdungskabelverschraubung
earth cable joint
raccord de câble de mise à la terre

= A
+ H
- M1

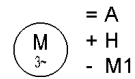

Motor Hubwerk
motor hoist gear /
moteur mécan. de levage

= S1
- X1

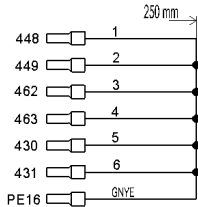

202

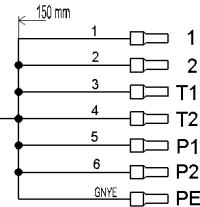

= A
+ H
- M1

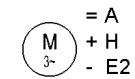

Fremdlüfter Hubwerk
separate fan hoist gear /
ventilateur séparé
mécan. de levage

= S1
- X1

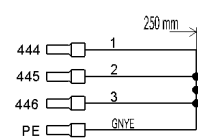

204

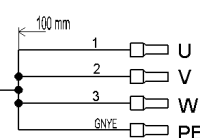

= A
+ H
- E2

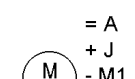

Montagewerk Motor
erection gear Motor /
moteur mécan. d' montage

= S1
+ J
- Q2
= S1
- X1

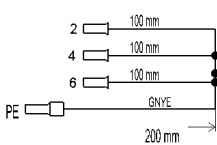

207

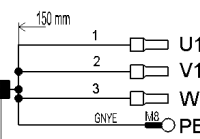

Erdungskabelverschraubung
earth cable joint
raccord de câble de mise à la terre

= A
+ J
- M1

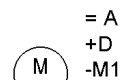

Motor Drehwerk
motor slewing gear /
moteur mécan. d'orientation

= S1
- X1

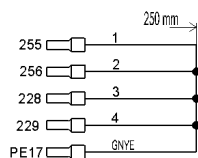

206

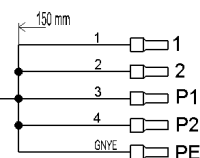

= A
+ J
- M1

= S1
+ D
- Q2
= S1
- X1

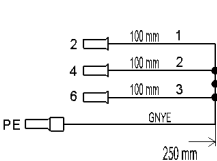

211

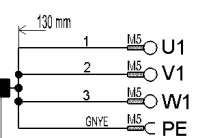

Erdungskabelverschraubung
earth cable joint
raccord de câble de mise à la terre

= A
+ D
- M1

= S1
- X1

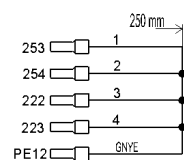

210

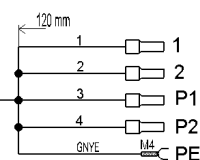

= A
+ D
- M1

= S1
+ K
- T1

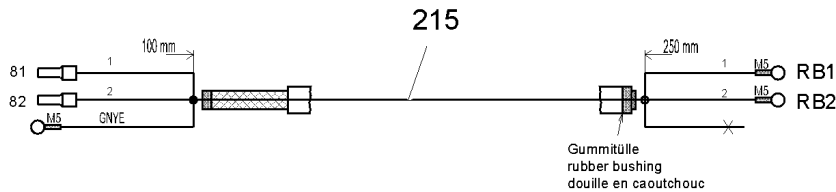

= S1
+ H
- T1

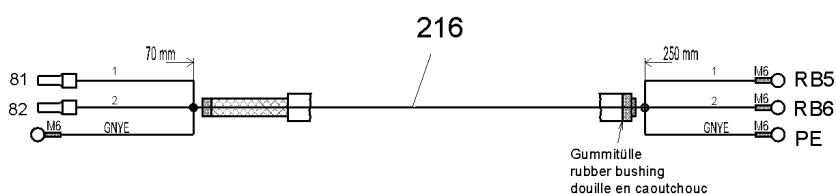

= S1
+ D
- T1

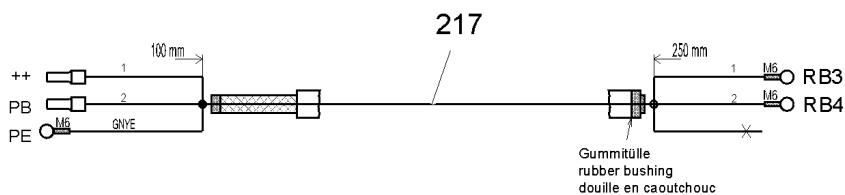

= S1
- X1

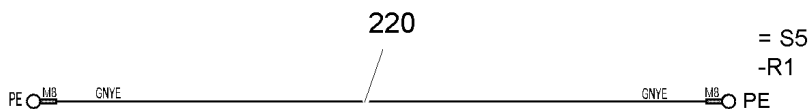
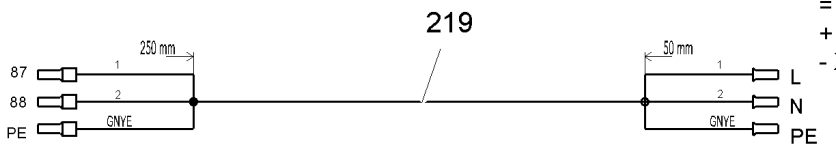

= S5
- R1

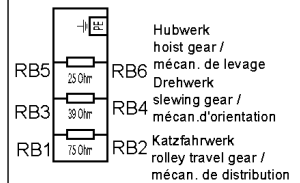

= S5
+ A
- X10

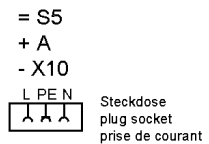

in Stückliste S5
in list of parts S5
dans la liste des pièces S5



Erdung Widerstandsplatte
earthing, resistor plate
mise à la terre, plaque de
résistances

Pos.	Artikel	Menge	Bezeichnung	Description	Serie
202	600355201	2.9m	LEITUNG	LEAD	20120308-
203	10454274	3.3m	LEITUNG 4G 10mm ²	LEAD	20120308-
204	600352201	3.2m	LEITUNG	LEAD	20120308-
206	600304305	2.7m	LEITUNG 5G1,5mm ²	LEAD	20100629-
207	10176139	2.8m	LEITUNG 4G 4mm ² ABGESCHIRMT	LEAD	20110711-
210	600304305	4m	LEITUNG 5G1,5mm ²	LEAD	20100629-
211	10176139	4m	LEITUNG 4G 4mm ² ABGESCHIRMT	LEAD	20110711-
215	10176137	5m	LEITUNG 4G 2,5mm ² ABGESCHIRMT	LEAD	20120308-
216	10176139	5m	LEITUNG 4G 4mm ² ABGESCHIRMT	LEAD	20120308-
217	10176139	5m	LEITUNG 4G 4mm ² ABGESCHIRMT	LEAD	20120308-
219	600308305	4m	LEITUNG 3G1,5mm ²	LEAD	20110117-
220	600148201	0.2m	LEITUNG	LEAD	20120308-

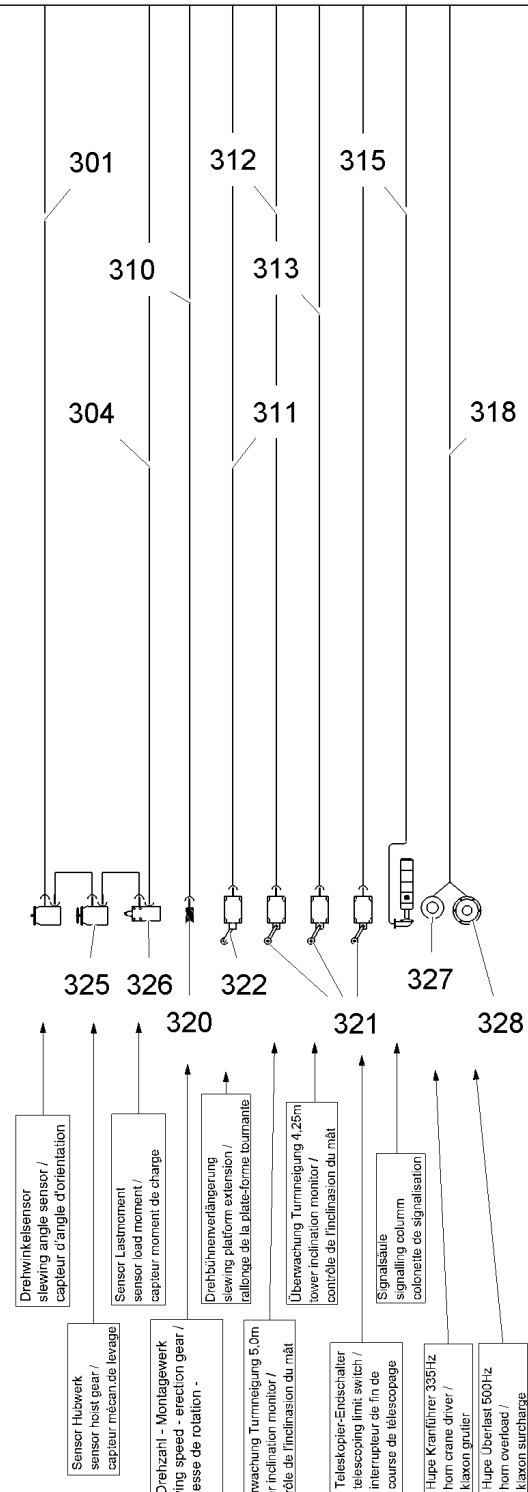

**Elektroinstallation Drehbühne 81 K -
 Leitungen, Endschafter, Sensoren**

Electric installation, slewing platform -
 cables, limit switches, sensors
 Installation électrique, plate-forme tournante -
 lignes, interrupteurs de fin de course, détecteurs
 Installazione elettrica, piattaforma girevole -
 linee, interruttori finecorsa, sensori
 Instalación eléctrica, plataforma de giro -
 líneas, interruptores de fin de carrera, sensores
 электроинсталляция поворотной платформы -
 эл. проводка / кабели, концевые выключатели, датчики
 A 120.800 - 411.300 (1.0)

308120

23.4.2012
 308120

LIEBHERR

**GESAMTLISTE
 OVERALL SURVEY
 E-INST. DREHBUEHNE
 EL.INST. SLEWING PLATFORM**

142 (1/3)

90 01 456 5

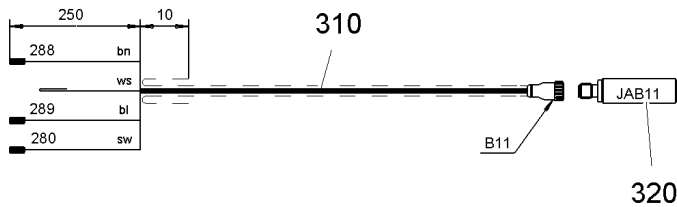

Überwachung Drehzahl - Montagewerk
 monitoring slewing speed - erection gear /
 surveillance vitesse de rotation -
 mécan.de montage

320

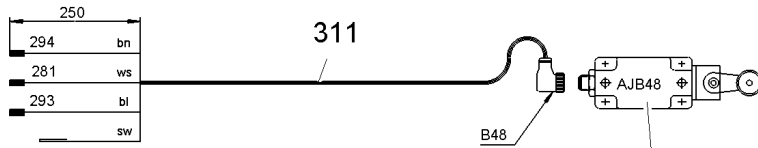

Drehbühnenverlängerung
 slewing platform extension /
 rallonge de la plate-forme tournante

322

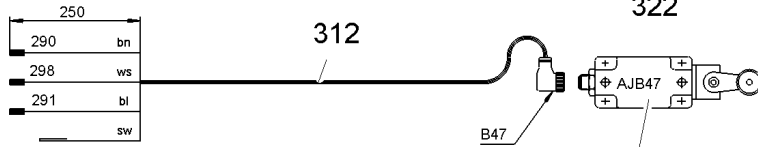

Überwachung Turmneigung 5,0m
 tower inclination monitor /
 contrôle de l'inclinaison du mât

321

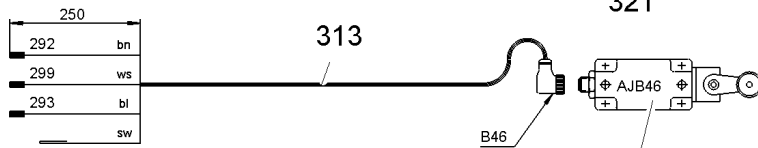

Überwachung Turmneigung 4,25m
 tower inclination monitor /
 contrôle de l'inclinaison du mât

321

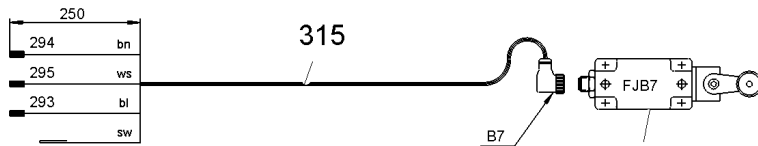

Teleskopier-Endschalter
 telescoping limit switch /
 interrupteur de fin de
 course de télescopage

321

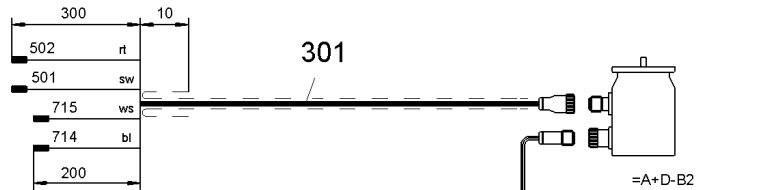

*) Drehwinkelsensor
 slewing angle sensor /
 capteur d'angle d'orientation

wird ohne Sensor gebrückt
 bridged without sensor
 shunté sans capteur

Code nach Schaltplan 4005-22461
 code according to circuit diagram 4005-22461
 code suivant schéma électrique 4005-22461

302

303

=A+D-B2

325

Sensor Hubwerk
 sensor hoist gear /
 capteur mécan.de levage

=A+H-B5

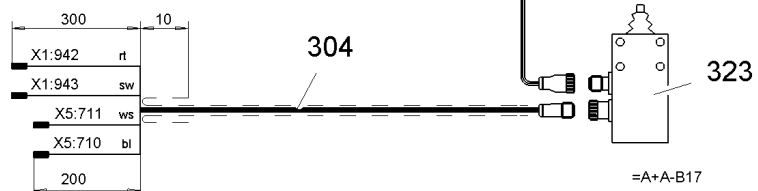

Sensor Lastmoment
 sensor load moment /
 capteur moment de charge

=A+A-B17

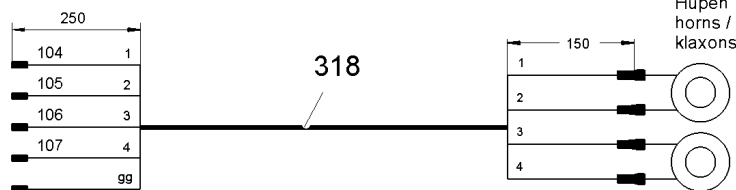

Hupen
 horns /
 klaxons

328

24V DC 500Hz

327

24V DC 335Hz

*) nicht serienmäßig /
 not standard /
 hors série
 non di serie /
 no estándar /
 не серийно

A 120.800 - 411.300 / Bl. 2 (1.0)

308121

23.4.2012
 308121

LIEBHERR

**GESAMTLISTE
 OVERALL SURVEY
 E-INST. DREHBUEHNE
 EL.INST. SLEWING PLATFORM**

143 (2/3)

90 01 456 5

Pos.	Artikel	Menge	Bezeichnung	Description	Serie
301	10171980	1	STECKVERBINDER	PLUG CONNECTOR	
302	10171967	1	STECKVERBINDER	PLUG CONNECTOR	20100318-
303	10171965	1	STECKVERBINDER	PLUG CONNECTOR	20100318-
304	10171975	1	STECKVERBINDER	PLUG CONNECTOR	
310	10045555	1	STECKVERBINDER 4-POL. 5m LANG	PLUG CONNECTOR	
311	10045544	1	STECKVERBINDER 4-POL. 5m LANG	PLUG CONNECTOR	
312	10045544	1	STECKVERBINDER 4-POL. 5m LANG	PLUG CONNECTOR	20100318-
313	10045544	1	STECKVERBINDER 4-POL. 5m LANG	PLUG CONNECTOR	20100318-
315	10173730	1	STECKVERBINDER 4X0,34mm ² L=20m	PLUG CONNECTOR	20100318-
318	600304305	1.8m	LEITUNG 5G1,5mm ²	LEAD	20100630-
320	10169346	1	INDUKTIVSENSOR	INDUCTIVE SENSOR	
321	10040125	3	ENDSCHALTER	LIMIT SWITCH	20100630-
322	10175807	1	ENDSCHALTER	LIMIT SWITCH	20110520-
325	90014944	1	HUBWERKSSENSOR ⇒  145	HOIST GEAR SENSOR	
326	10173714	1	POTENTIOMETER	POTENTIOMETER	
327	614060301	1	HUPE	HORN	20101012-
328	614060401	1	HUPE	HORN	20101012-
329	726614901	4	GUMMIKAPPE	RUBBER CAP	20101012-

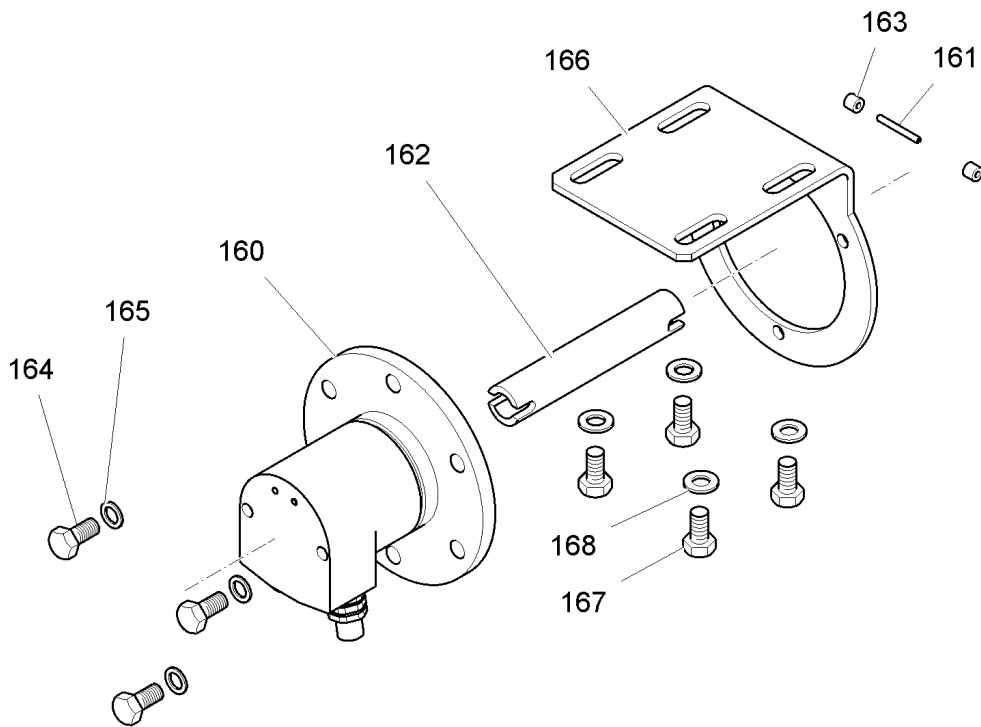

ELZ 020 AF 088 - 000

308122-

Pos.	Artikel	Menge	Bezeichnung	Description	Serie
160	10171846	1	ABSOLUTWERTGEBER	ABSOLUTE VALUE TRANSDUCE	
161	432000901	1	SPANNSTIFT 3	DOWEL PIN	
162	933819801	1	MITNEHMER	DRIVER	
163	774207801	0.012m	SCHLAUCH 7X3	HOSE	
164	4900188	3	SECHSKANTSCHRAUBE ISO 4017 M8x16 8.8 A2	HEX HEAD SCREW	
165	423910801	3	SICHERUNGSSCHEIBE 8,4/13X1,7 VS 8	LOCK WASHER	
166	90008208	1	LAGERBLECH 4X120X231	BRACKET	
167	4900188	4	SECHSKANTSCHRAUBE ISO 4017 M8x16 8.8 A2	HEX HEAD SCREW	
168	420001201	4	SCHEIBE 8	WASHER	

23.4.2012
308122

LIEBHERR

GESAMTLISTE
OVERALL SURVEY
HUBWERKSSENSOR
HOIST GEAR SENSOR

145

90 01 494 4