

1	2	3	4	5	6	7	8
<p>***** * Blattverzeichnis Datum: 24.07.03 Seite: 1 * ***** * Zeichnungs-Nr.: 4005-21962 * LIEBHERR-WERK * * Bezeichnung: STROMLAUFPLAN S1 * BIBERACH GmbH * * Type : 112-156 EC-HM * 88400 BIBERACH * * Werk-Nr. : * * Identnummer: 932887401 * *****</p>							
B							
Blatt Blattbezeichnung Ort Datum Name =====							
Anlage: KPLAN =====							
1	142-KLEMMENPLAN		24.07.03 KUGLER				
TERMINAL PLAN SCHEMA DES BORNES							
Anlage: S1 =====							
1	197-INHALTSVERZEICHNIS		25.06.03 KUGLER				
LIST OF CONTENTS SOMMAIRE							
2	197-INHALTSVERZEICHNIS		25.06.03 KUGLER				
LIST OF CONTENTS SOMMAIRE							
3	11-EINSPESISUNG		26.06.03 KUGLER				
SUPPLY ALIMENTATION							
4	9-SCHRANKHEIZUNG (EN)		26.06.03 KUGLER				
SWITCH BOX HEATING (S) CHAUFFAGE (S) ARM. ELECTR.							
5	16-STEUERUNG		26.06.03 KUGLER				
CONTROL SYSTEM SYSTEME DE COMMANDE							
6	16-STEUERUNG		26.06.03 KUGLER				
CONTROL SYSTEM SYSTEME DE COMMANDE							
7	16-STEUERUNG		26.06.03 KUGLER				
CONTROL SYSTEM SYSTEME DE COMMANDE							
8	16-STEUERUNG		26.06.03 KUGLER				
CONTROL SYSTEM SYSTEME DE COMMANDE							
E							
9 16-STEUERUNG 26.06.03 KUGLER CONTROL SYSTEM SYSTEME DE COMMANDE							
10 26-STROMKREIS 26.06.03 KUGLER CIRCUIT CIRCUIT ELECTRIQUE							
11 27-DREHWERK 26.06.03 KUGLER SLEWING GEAR MÜC.DORIENTATION							
12 27-DREHWERK 26.06.03 KUGLER SLEWING GEAR MÜC.DORIENTATION							
13 27-DREHWERK 26.06.03 KUGLER SLEWING GEAR MÜC.DORIENTATION							
14 27-DREHWERK 26.06.03 KUGLER SLEWING GEAR MÜC.DORIENTATION							
15 27-DREHWERK 26.06.03 KUGLER SLEWING GEAR MÜC.DORIENTATION							
16 41-WINDFREISTELLUNG 26.06.03 KUGLER WIND RELEASE MISE EN GIROUETTE							
17 41-WINDFREISTELLUNG 26.06.03 KUGLER WIND RELEASE MISE EN GIROUETTE							
18 41-WINDFREISTELLUNG 26.06.03 KUGLER WIND RELEASE MISE EN GIROUETTE							
19 28-FAHRWERK 26.06.03 KUGLER TRAVELLING GEAR L'ENSEMBLE DE TRANSLATION							
20 41-WINDFREISTELLUNG 26.06.03 KUGLER WIND RELEASE MISE EN GIROUETTE							
21 28-FAHRWERK 26.06.03 KUGLER TRAVELLING GEAR L'ENSEMBLE DE TRANSLATION							
22 29-KATZFAHRWERK 26.06.03 KUGLER TROLLEY TRAVEL GEAR MÜC.DISTRIBUTION							
23 29-KATZFAHRWERK 26.06.03 KUGLER TROLLEY TRAVEL GEAR MÜC.DISTRIBUTION							
24 29-KATZFAHRWERK 26.06.03 KUGLER TROLLEY TRAVEL GEAR MÜC.DISTRIBUTION							
TYPE 112-156 EC-HM							
Zeilch.-Nr. 4005-21962							
Ident. Nr. 932887401							

1	2	3	4	5	6	7	8
	MÜC.DE DISTRIBUTION						
25	29-KATZFAHRWERK						
	TROLLEY TRAVEL GEAR						
	MÜC.DE DISTRIBUTION						
26	29-KATZFAHRWERK						
	TROLLEY TRAVEL GEAR						
	MÜC.DE DISTRIBUTION						
27	29-KATZFAHRWERK						
	TROLLEY TRAVEL GEAR						
	MÜC.DE DISTRIBUTION						
28	29-KATZFAHRWERK						
	TROLLEY TRAVEL GEAR						
	MÜC.DE DISTRIBUTION						
29	29-KATZFAHRWERK						
	TROLLEY TRAVEL GEAR						
	MÜC.DE DISTRIBUTION						
30	54-STUERSTAND						
	CONTROL STAND						
	POSTE DE COMMANDE						
31	5-STECKVORRICHTUNG						
	PLUG-IN DEVICE						
	DISPOSITIF ENFICHABLE						
32	5-STECKVORRICHTUNG						
	PLUG-IN DEVICE						
	DISPOSITIF ENFICHABLE						
33	497-EMS-MODUL						
	EMS-MODULE						
	EMS-MODULE						
34	313-SENSOREN						
	SENSORS						
	CAPTEURS						
35	5-STECKVORRICHTUNG						
	PLUG-IN DEVICE						
	DISPOSITIF ENFICHABLE						
36	5-STECKVORRICHTUNG						
	PLUG-IN DEVICE						
	DISPOSITIF ENFICHABLE						
37	5-STECKVORRICHTUNG						
	PLUG-IN DEVICE						
	DISPOSITIF ENFICHABLE						
38	5-STECKVORRICHTUNG						
	PLUG-IN DEVICE						
	DISPOSITIF ENFICHABLE						
39	5-STECKVORRICHTUNG						
	PLUG-IN DEVICE						
	DISPOSITIF ENFICHABLE						

 Ende der Liste

3		Gez.	25.08.09	KUGLER	Maßstab	197-INHALTSVERZEICHNIS LIST OF CONTENTS SOMMAIRE	TYPE	112-156 EC-HM	=	SI
2		Bearb.	JULI03	KUGLER						
1		Änderung	Datum	Name	:	Zeich-Nr.		Blatt		Ident. Nr.
						4005-21962		2+		932887401

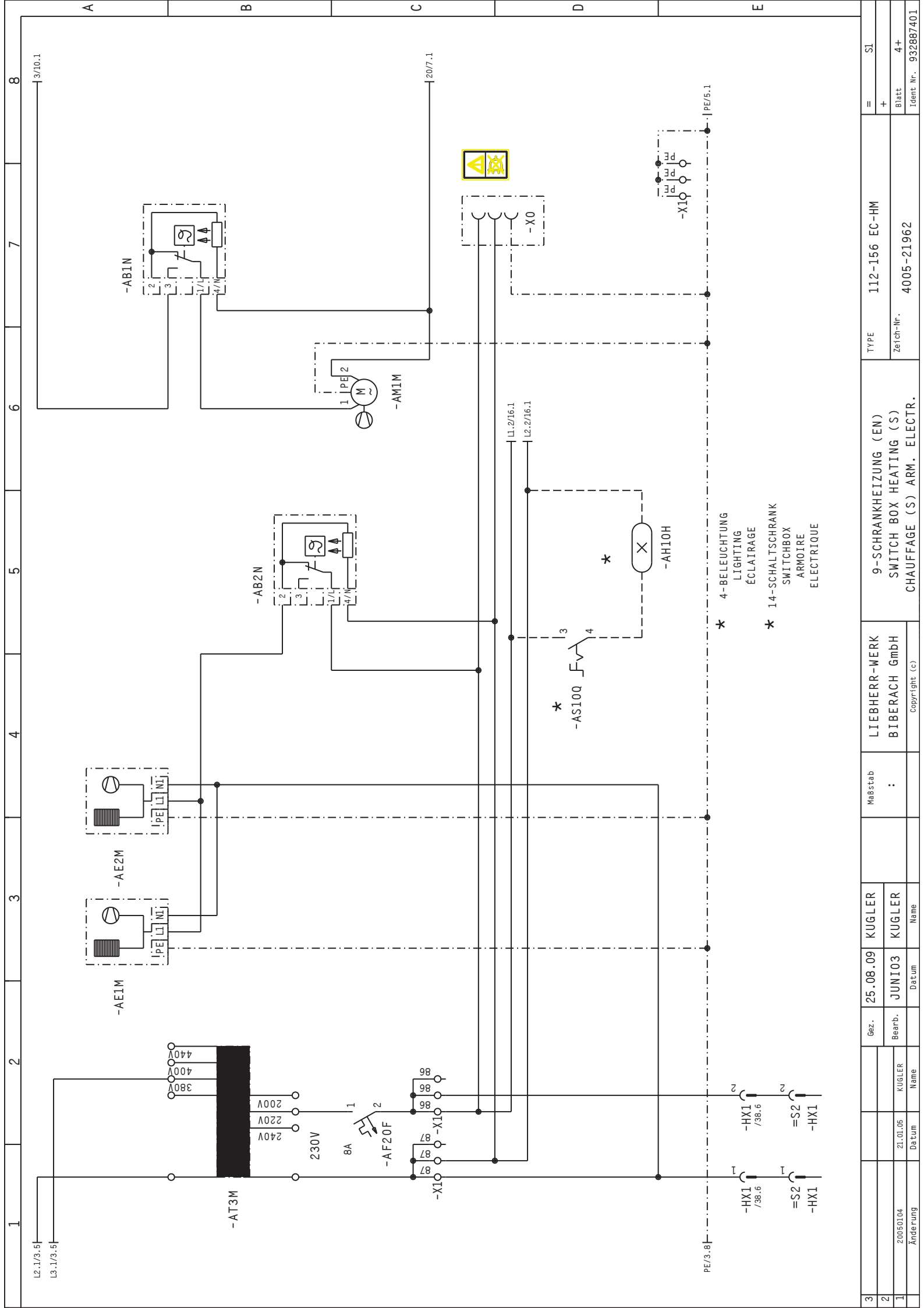

3	Gez.	25.08.09	KUGLER	Maßstab	1:1	LIEBHERR-WERK	9-SCHRANKHEIZUNG (EN)	TYPE	112-156 EC-HM	SI
2	Bearb.	JUNIO3	KUGLER	:		BIBERACH GmbH	SWITCH BOX HEATING (S)	Zeich-Nr.	4005-21962	Blatt
1	Änderung	21.01.05	Name				CHAUFFAGE (S) ARM. ELECTR.	Ident. Nr.	932887401	4+

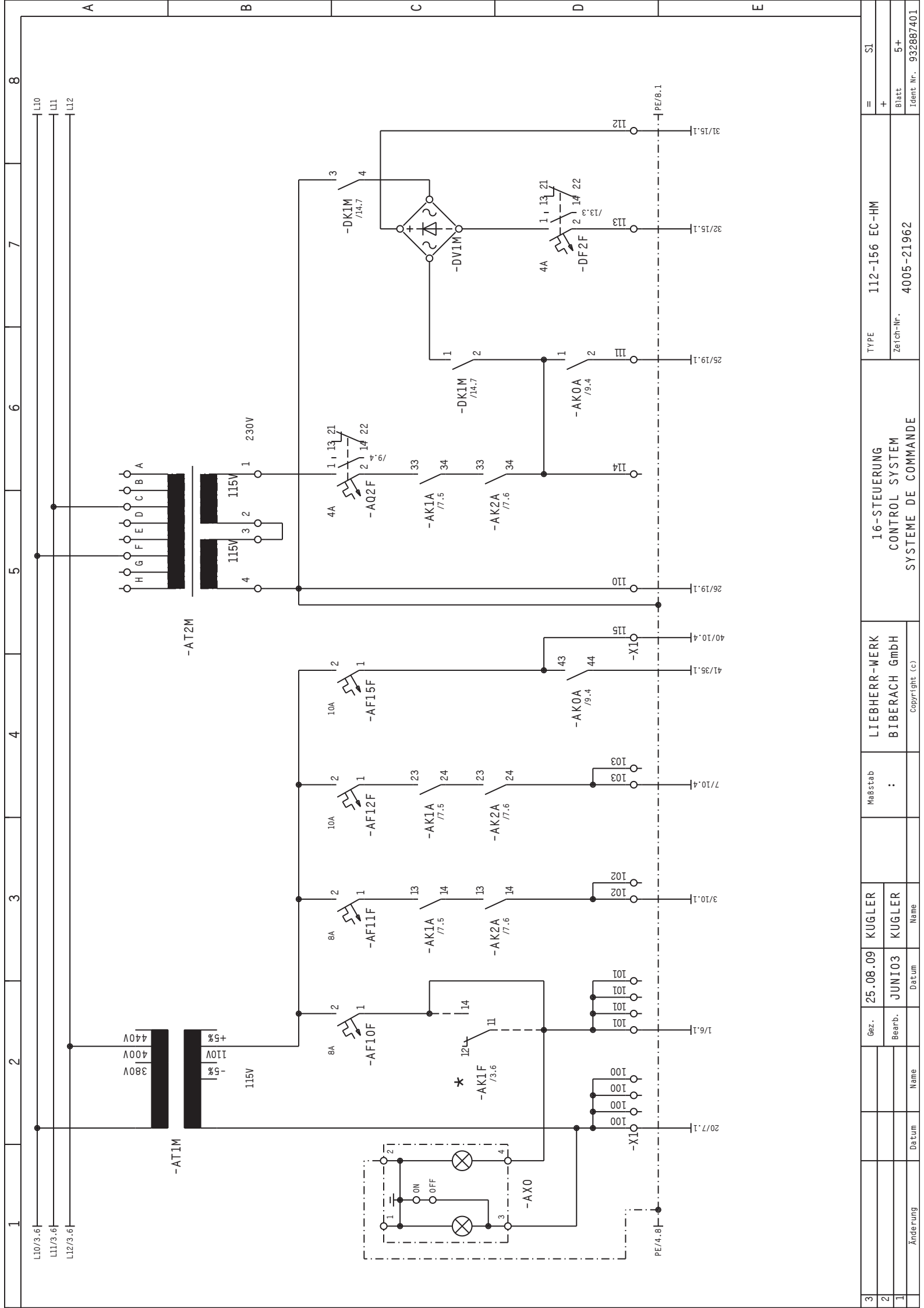

3	Änderung		Datum	Name	Gez.	25.08.09	KUGLER	Maßstab	1:1	LIEBHERR-WERK BIBERACH GmbH	16-STEUERUNG CONTROL SYSTEM SYSTEME DE COMMANDE	TYPE	112-156 EC-HM	=	SI
2					Bearb.	JUNIO3	KUGLER					Zeich-Nr.	4005-21962	+	Blatt
1												Ident-Nr.	932887401		5+

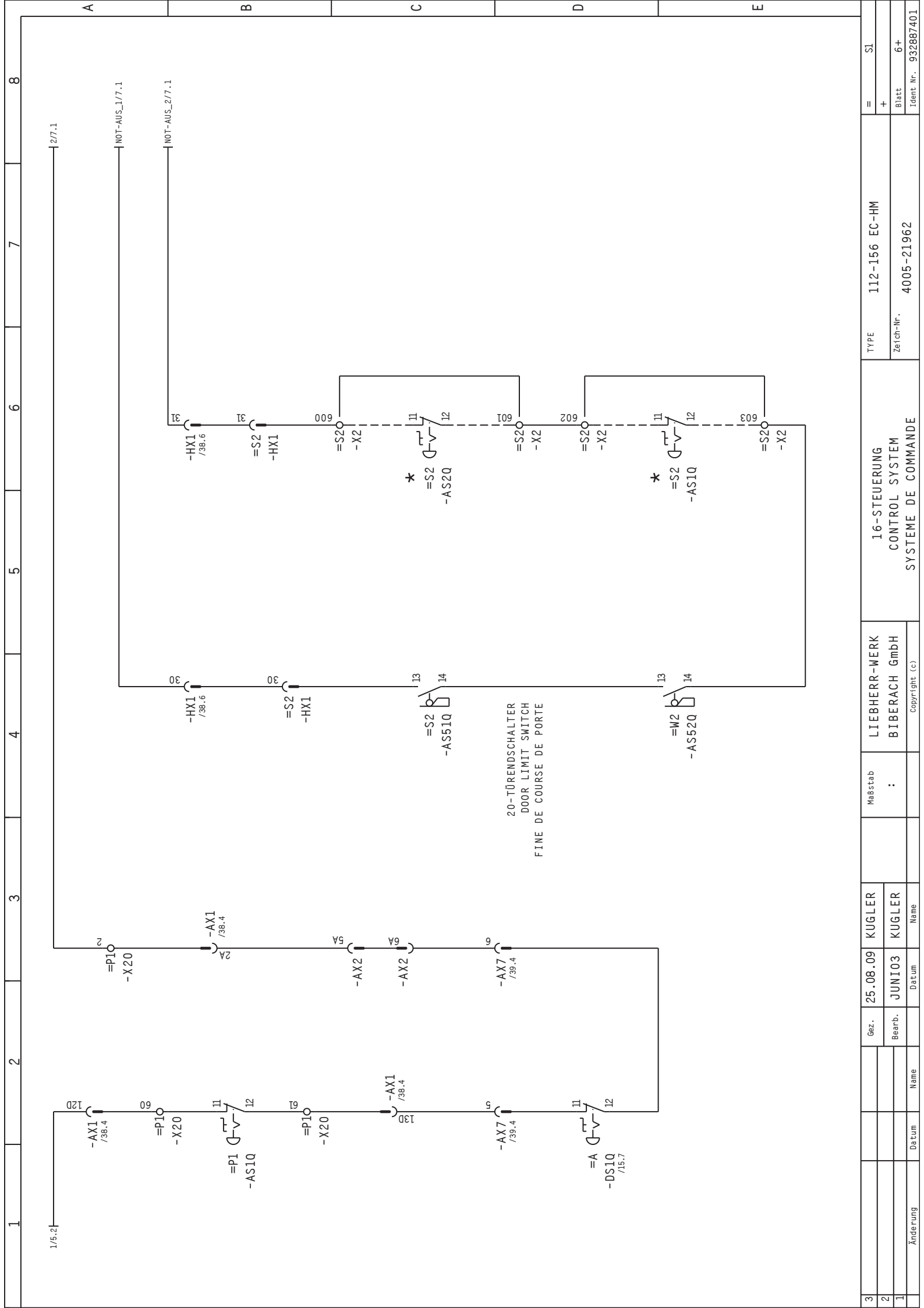

3			Gez.	25.08.09	KUGLER	Maßstab		112-156 EC-HM	TYPE	=	SI
2			Bearb.	JUNI03	KUGLER	:		CONTROL SYSTEM	Zeich-Nr.	+	Blatt
1								SYSTEME DE COMMANDE	4005-21962		6+
											Ident. Nr. 932887401

Copyright (c)

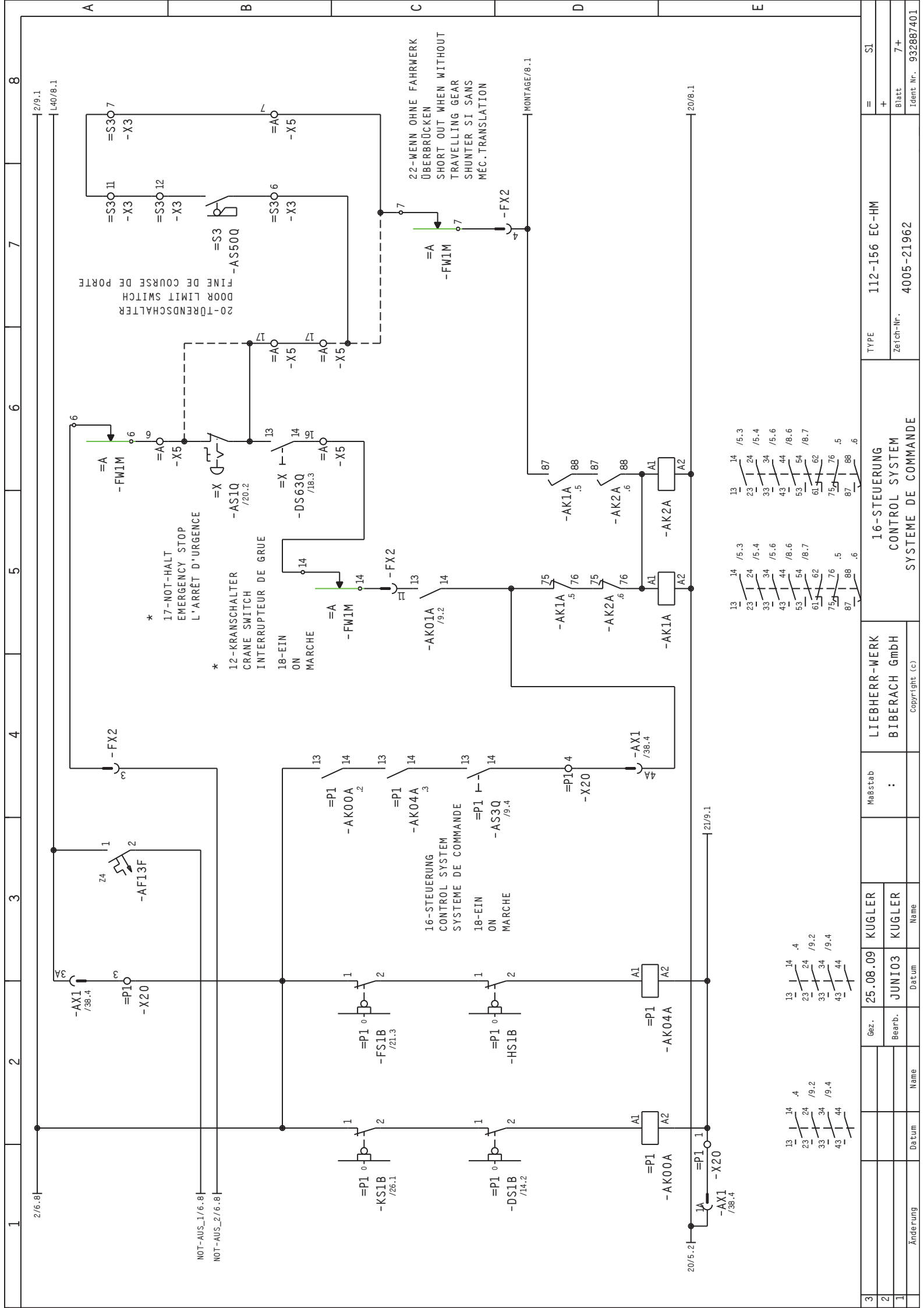

20-TÜRENDSCHALTER
 DOOR LIMIT SWITCH
 FINE DE COURSE DE PORTE

* 17-NOT-HALT
 EMERGENCY STOP
 L'ARRÊT D'URGENCE

* 12-KRANSCHALTER
 CRANE SWITCH
 INTERRUPTEUR DE GRUE

22-MENN OHNE FAHRWERK
 ÜBERBRÜCKEN
 SHORT OUT WHEN WITHOUT
 TRAVELLING GEAR
 SHUNTER SI SANS
 MEC. TRANSLATION

3	Änderung		Gez.	25.08.09	KUGLER	Maßstab	LIEBHERR-WERK BIBERACH GmbH	TYPE	112-156 EC-HM	SI
2			Bearb.	JUNIO3	KUGLER	:		Zeich.-Nr.	4005-21962	Blatt
1								Ident.-Nr.	932887401	7+

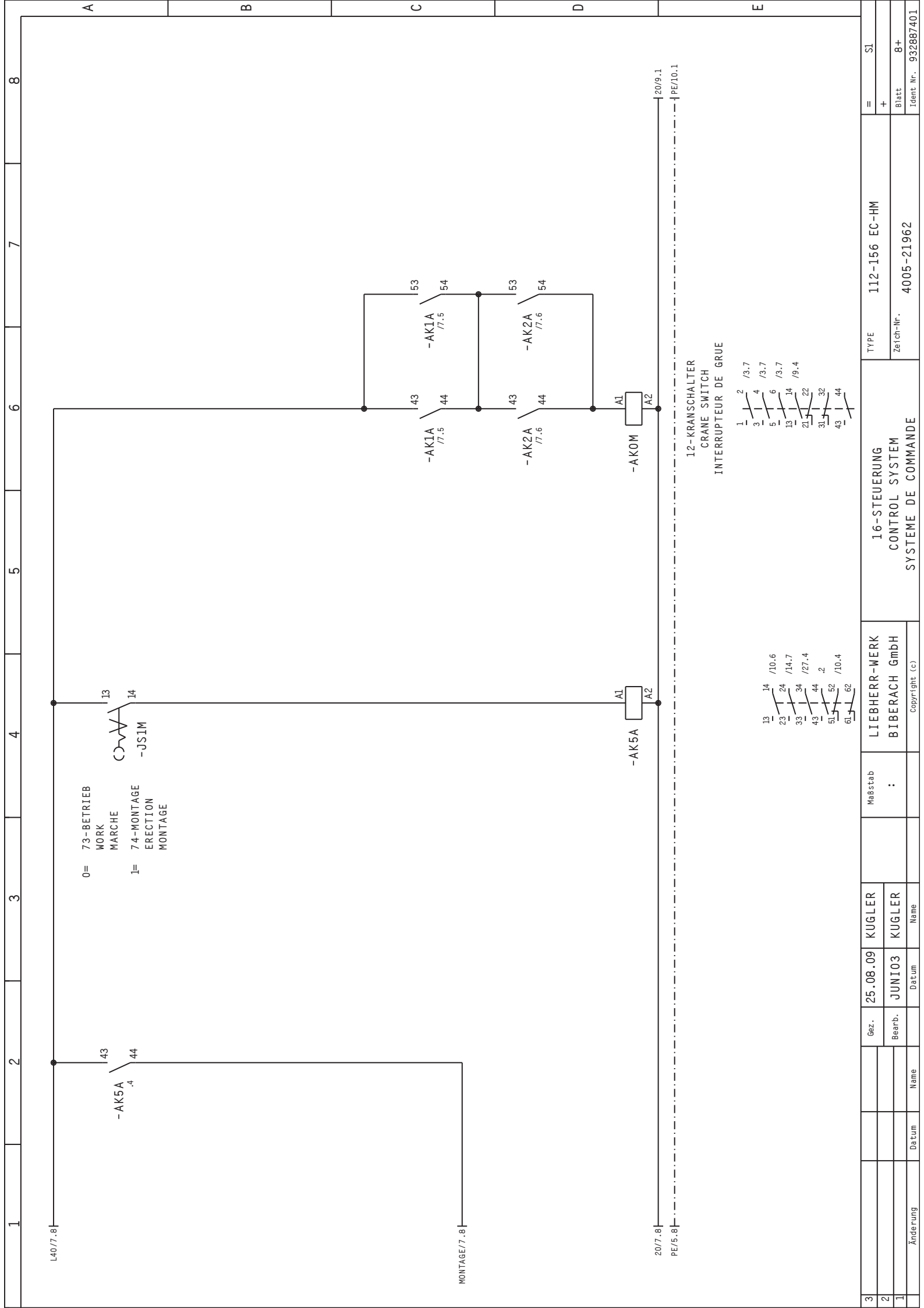

0= 73-BETRIEB
 WORK
 MARCHÉ

1= 74-MONTAGE
 ERECTION
 MONTAGE

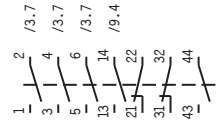
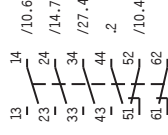

3		Gez.	25.08.09	KUGLER	Maßstab	LIEBHERR-WERK	TYPE	112-156 EC-HM	=	SI
2		Bearb.	JUN103	KUGLER	:	BIBERACH GmbH	Zeich-Nr.	4005-21962	+	8+
1	Änderung	Name	Datum	Name			Ident-Nr.	932887401		

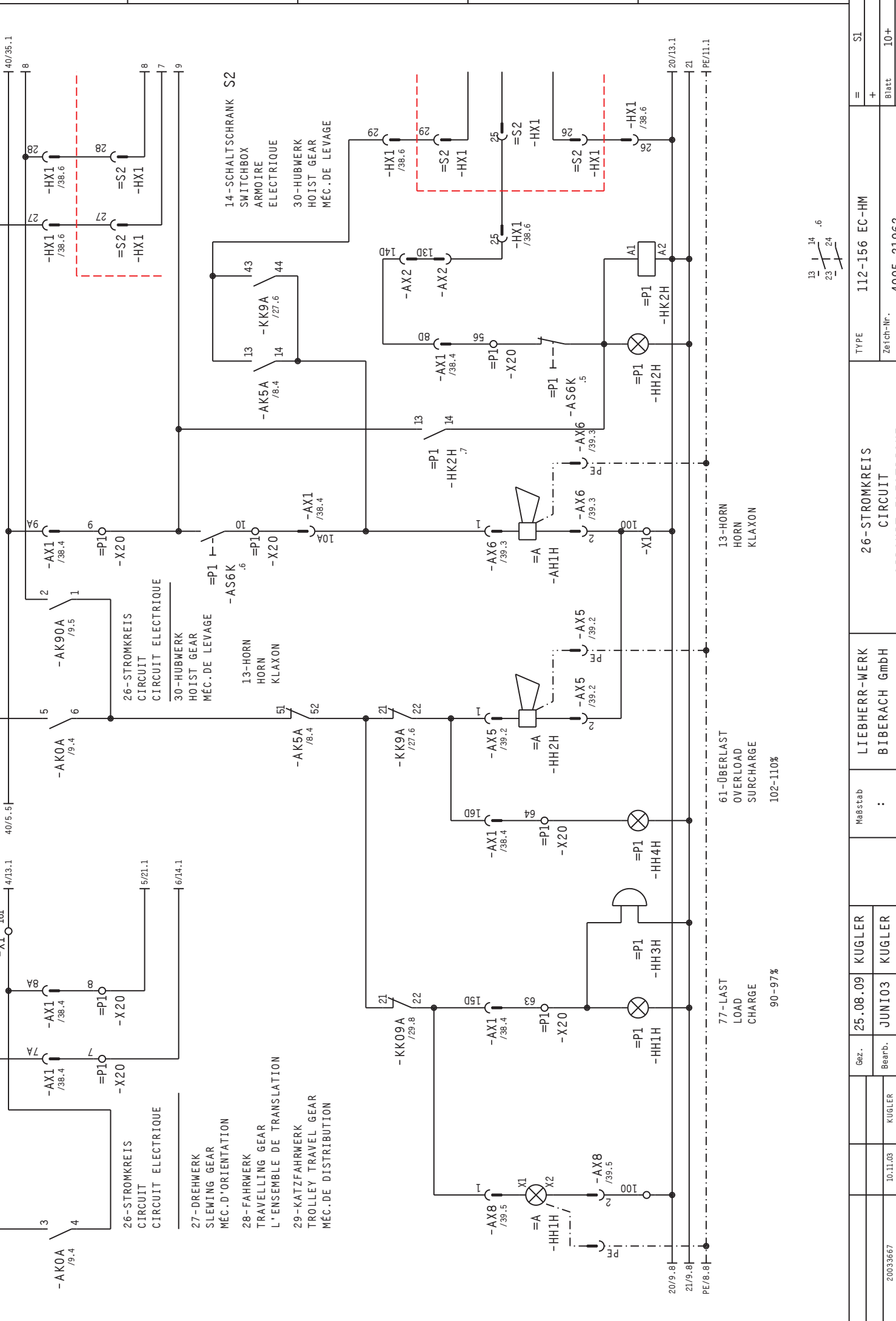
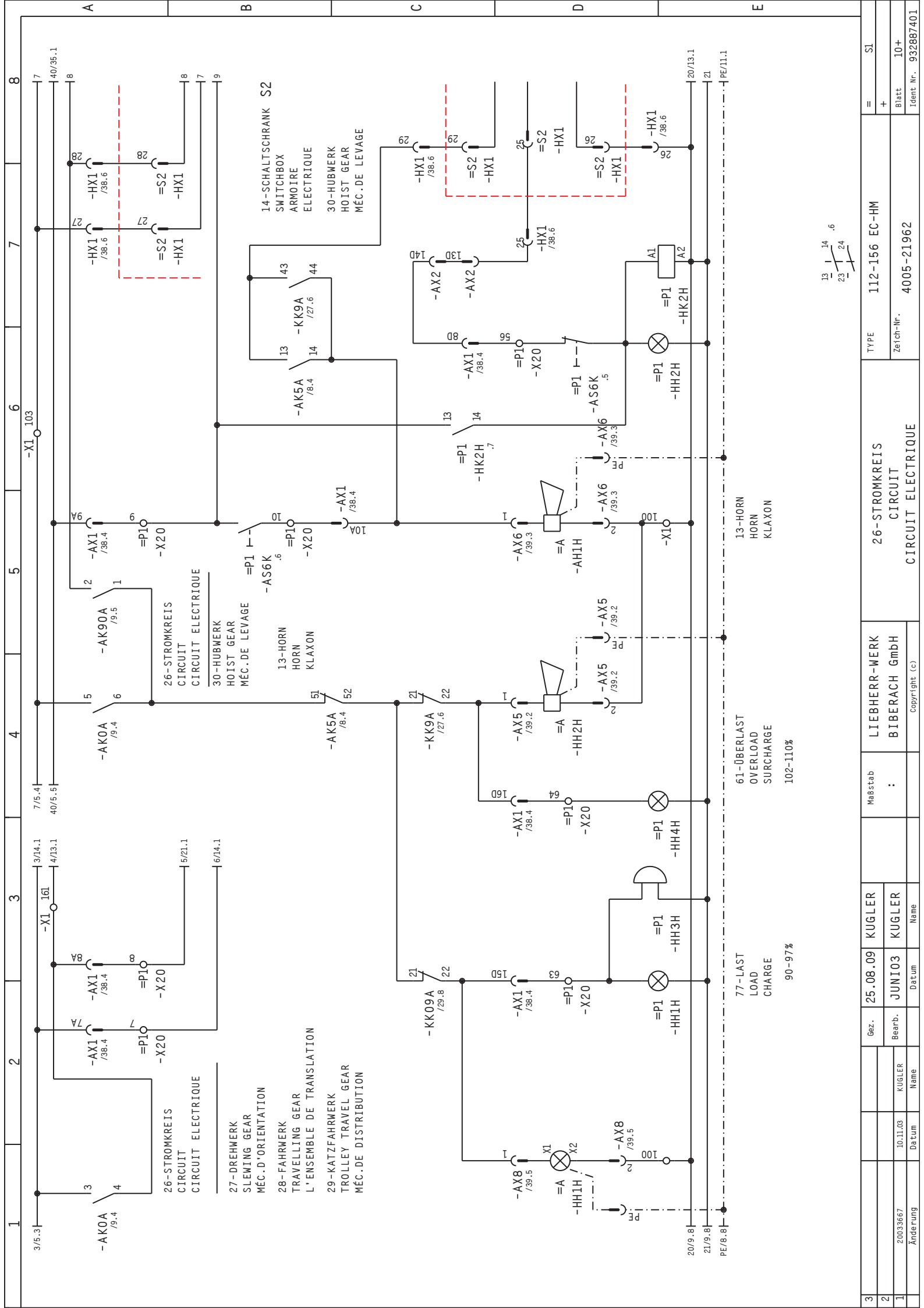

13 14
23 24

3		Gez.	25.08.09	KUGLER	Maßstab		LIEBHERR-WERK	TYPE	112-156 EC-HM	SI
2		Bearb.	JUNIO3	KUGLER	:		BIBERACH GmbH	Zeich.-Nr.	4005-21962	Blatt 10+
1	20035667	Datum	10.11.03	Name	Name			Ident.Nr.	932887401	
Änderung								26-STROMKREIS CIRCUIT ELECTRIQUE		

Copyright (c)

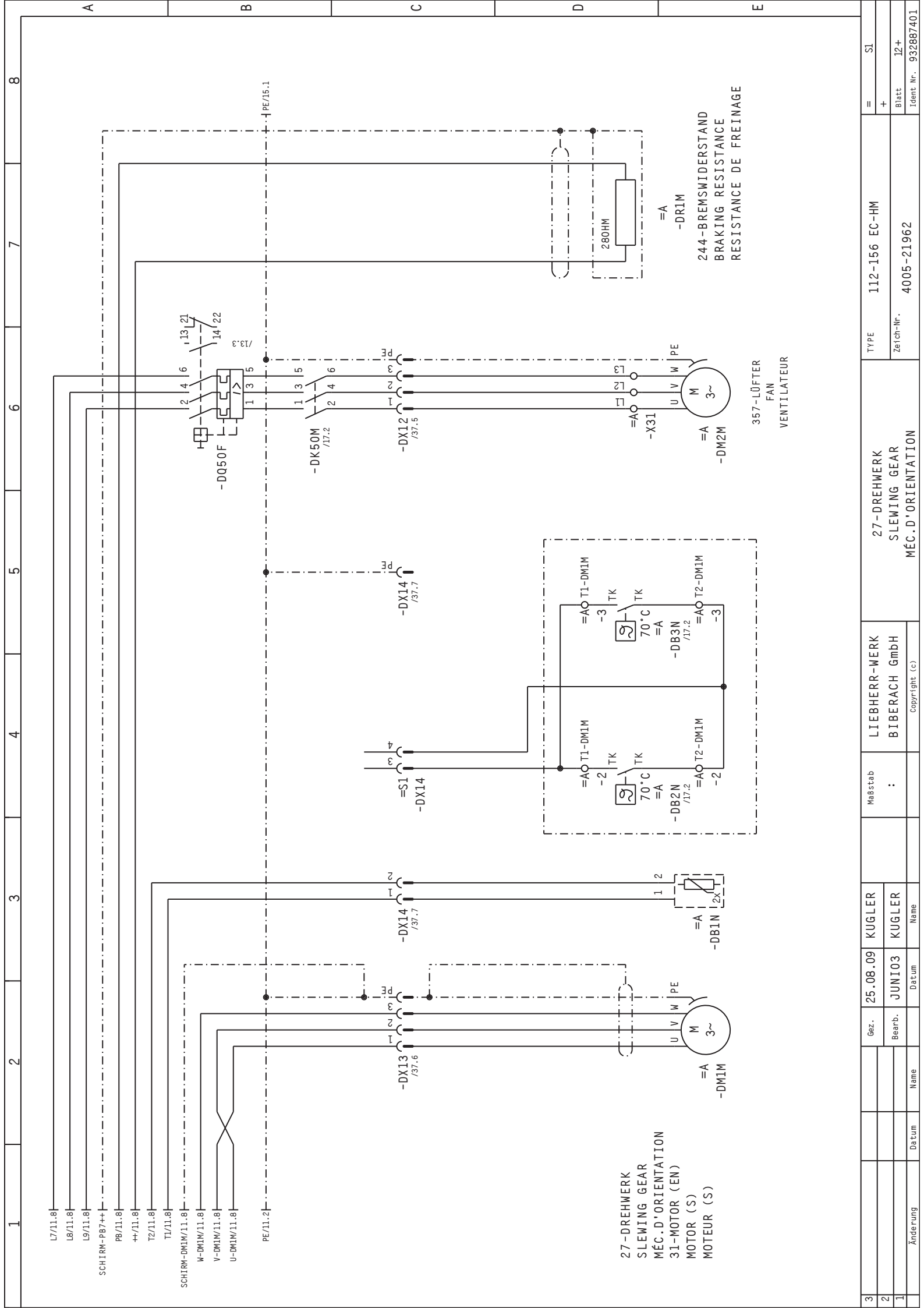

L7/11.8
 LB/11.8
 L9/11.8
 SCHIRM-PB7++
 PB/11.8
 ++/11.8
 TZ/11.8
 TL/11.8
 SCHIRM-DM1M/11.8
 W-DM1M/11.8
 V-DM1M/11.8
 U-DM1M/11.8
 PE/11.2

27-DREHWERK
 SLEWING GEAR
 MÉC.D'ORIENTATION
 31-MOTOR (EN)
 MOTOR (S)
 MOTEUR (S)

244-BREMSWIDERSTAND
 BRAKING RESISTANCE
 RESISTANCE DE FREINAGE

357-LÜFTER
 FAN
 VENTILATEUR

3	Gez.	25.08.09	KUGLER	Maßstab	1:1	27-DREHWERK SLEWING GEAR MÉC.D'ORIENTATION	TYPE	112-156 EC-HM	=	SI	
2	Bearb.	JUN103	KUGLER						+		
1	Änderung							Zeich-Nr.	4005-21962	Blatt	12+
								Ident-Nr.	932887401		

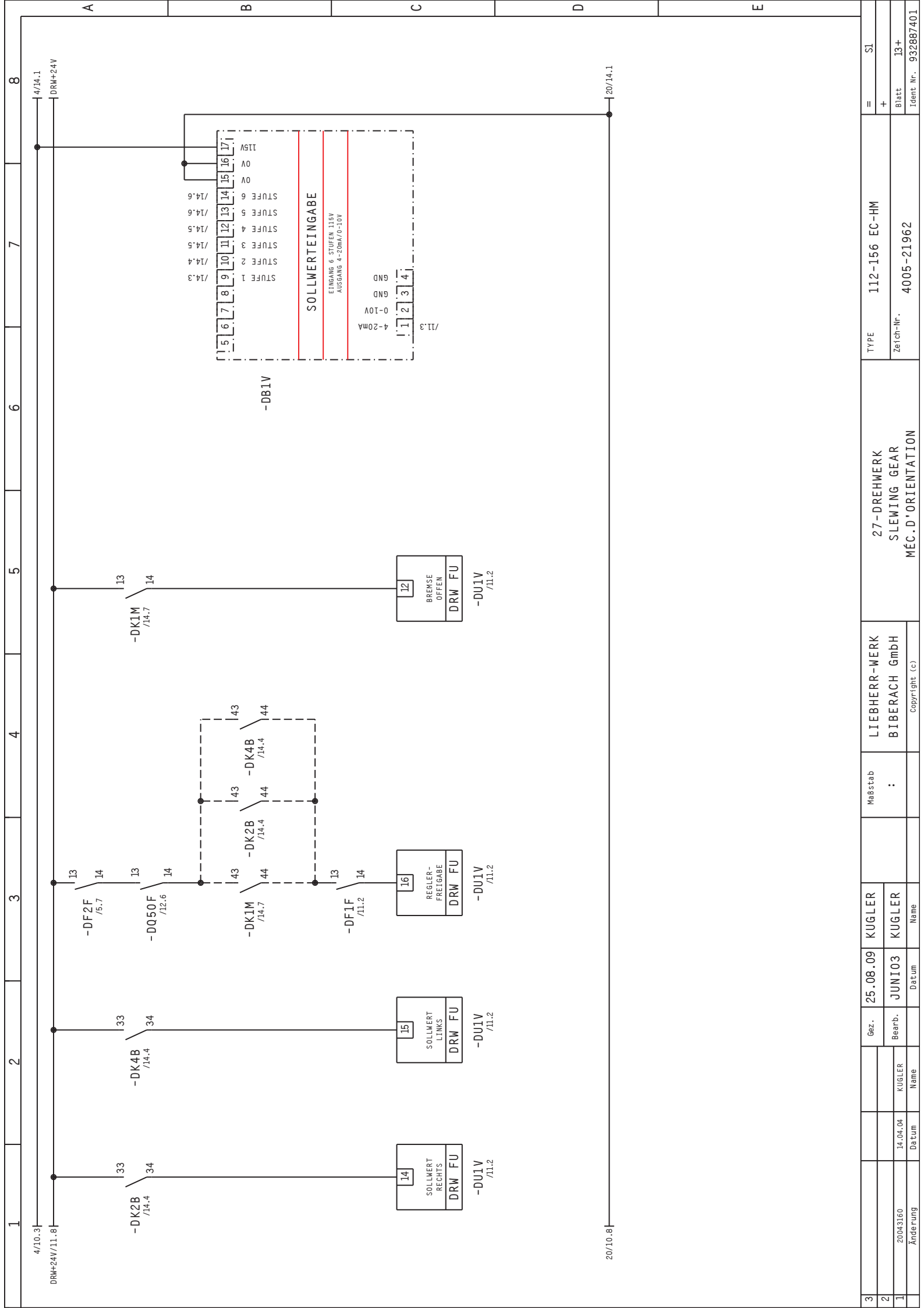

3	Gez.	25.08.09	KUGLER	Maßstab	27-DREHWERK SLEWING GEAR MÉC.D'ORIENTATION		TYPE	112-156 EC-HM	=	SI
2	Bearb.	JUNIO3	KUGLER	:	LIEBHERR-WERK BIBERACH GmbH		Zeich.-Nr.	4005-21962	+	Blatt 13+
1	Änderung	14.04.04	KUGLER				Ident.-Nr.	932887401		

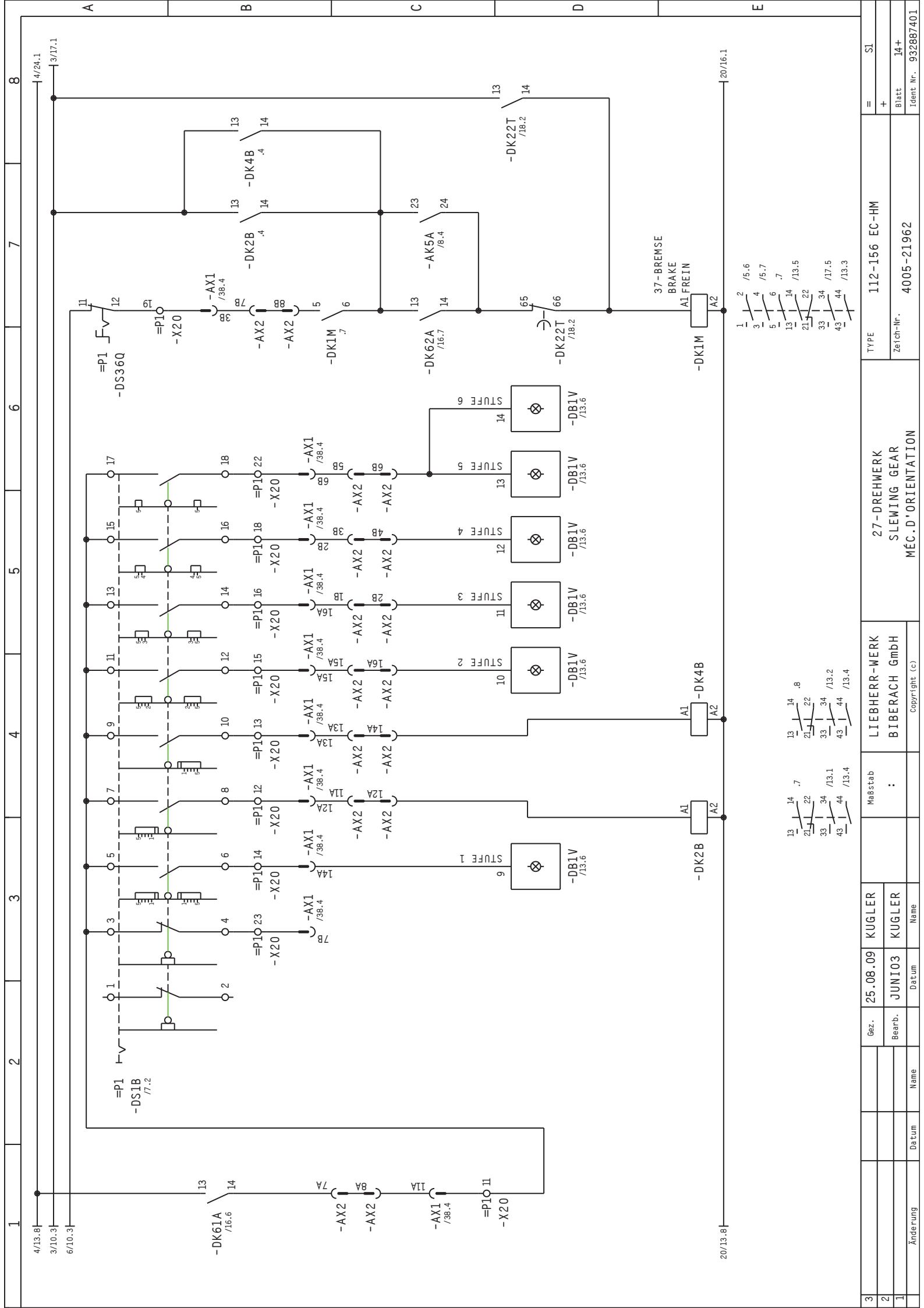

3	Gez.	25.08.09	KUGLER	Maßstab	1:1	LIEBHERR-WERK BIBERACH GmbH	TYPE	112-156 EC-HM	=	SI
2	Bearb.	JUNIO3	KUGLER			27-DREHWERK SLEWING GEAR MÉC.D'ORIENTATION	Zeich-Nr.	4005-21962	+	Blatt
1	Änderung									Ident. Nr.
										932887401

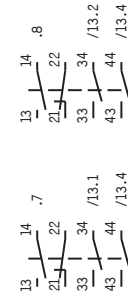

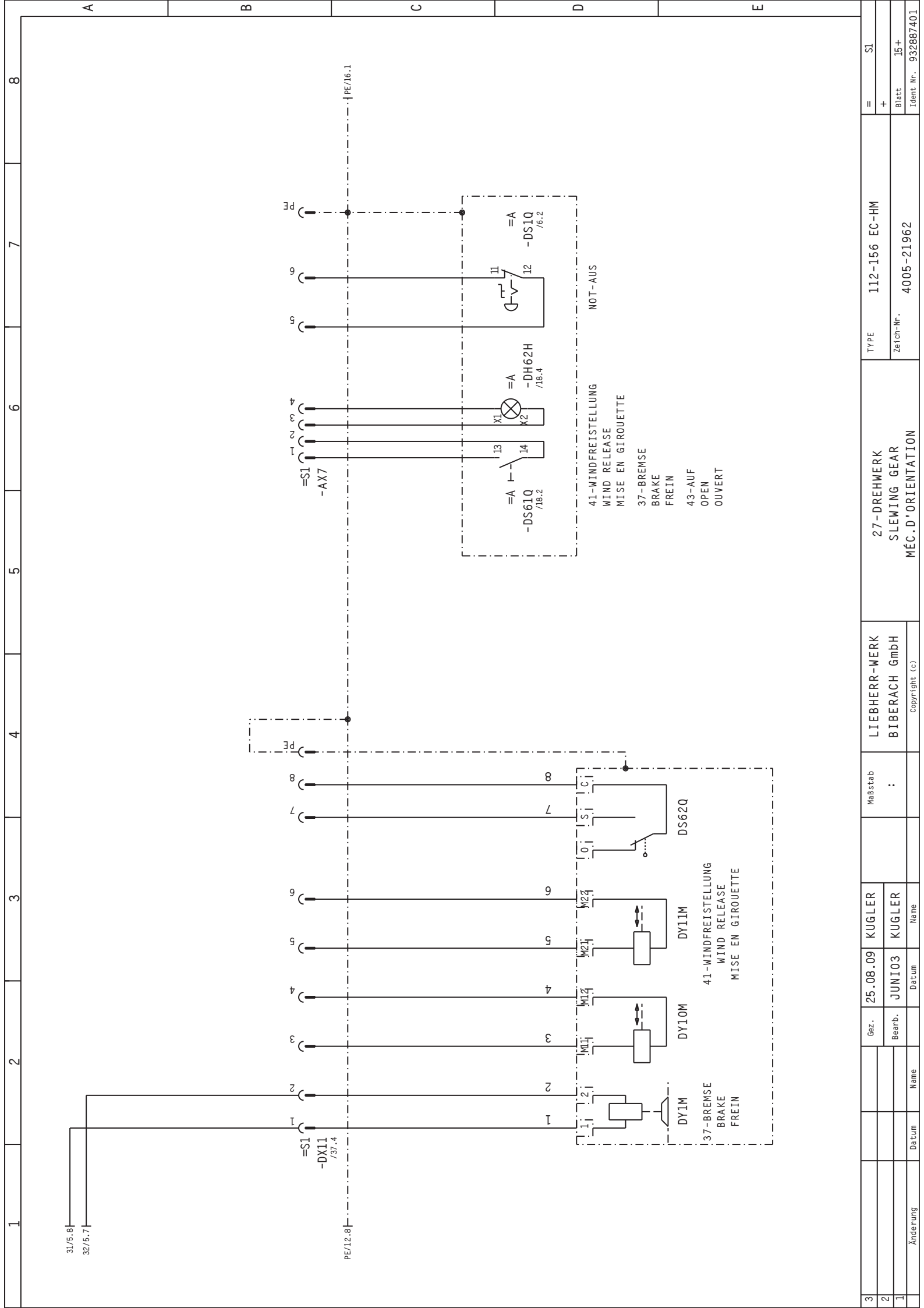

3	Gez.	25.08.09	KUGLER	Maßstab	LIEBHERR-WERK BIBERACH GmbH	TYPE	112-156 EC-HM	=	SI
2	Bearb.	JUN103	KUGLER	:	27-DREHWERK SLEWING GEAR	Zeich-Nr.	4005-21962	+	
1	Änderung	Datum	Name		MÉC.D'ORIENTATION	Ident-Nr.	932887401	Blatt	15+
						Ident-Nr.	932887401		

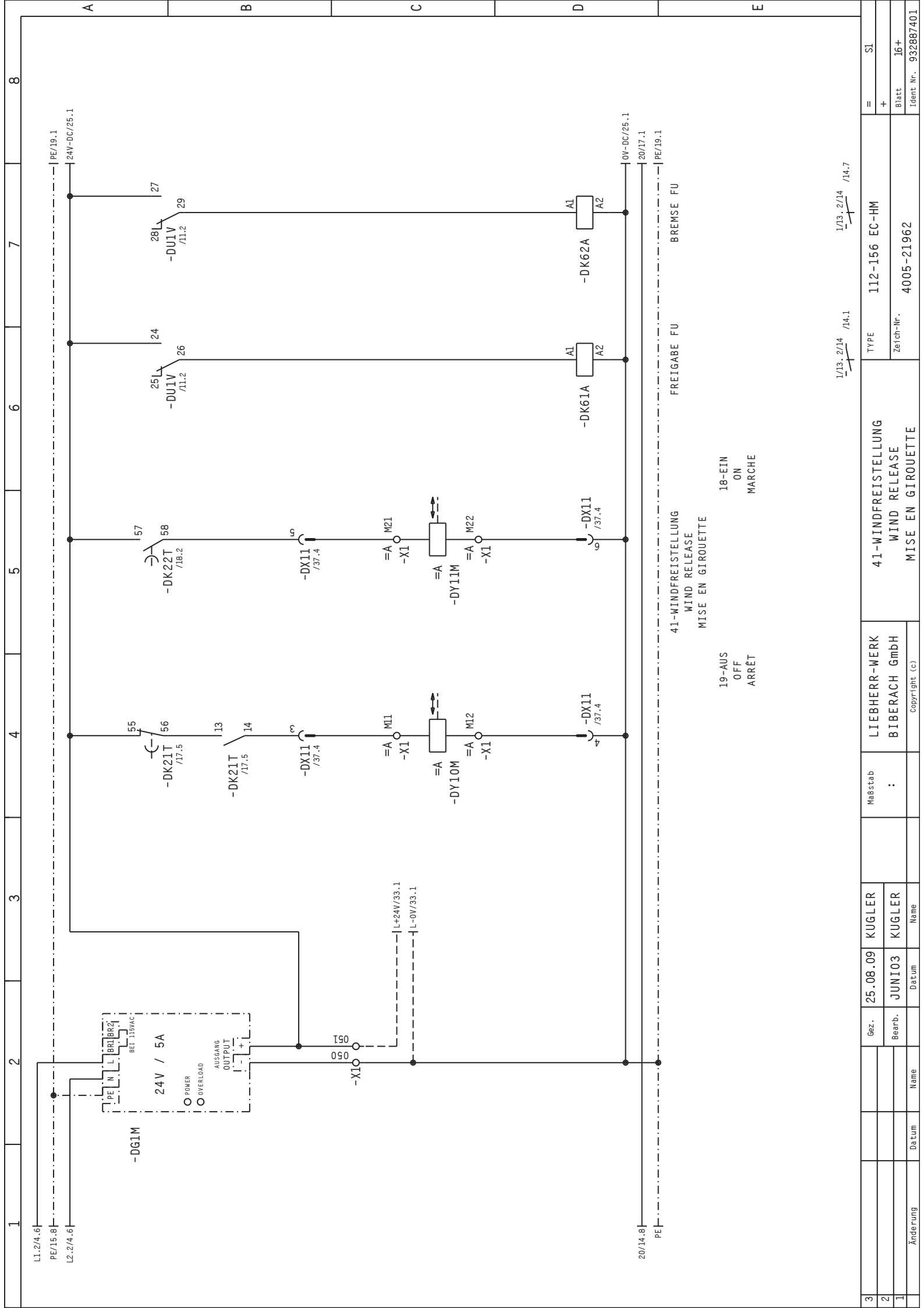

1/13, 2/14 /14.1

1/13, 2/14 /14.7

3	Gez.	25.08.09	KUGLER	Maßstab	LIEBHERR-WERK	41-WINDFREISTELLUNG	TYPE	112-156 EC-HM	=	SI
2	Bearb.	JUN103	KUGLER	:	BIBERACH GmbH	WIND RELEASE	Zeich-Nr.	4005-21962	+	Blatt 16+
1	Name					MISE EN GIROQUETTE	Ident-Nr.	932887401		Ident-Nr. 932887401

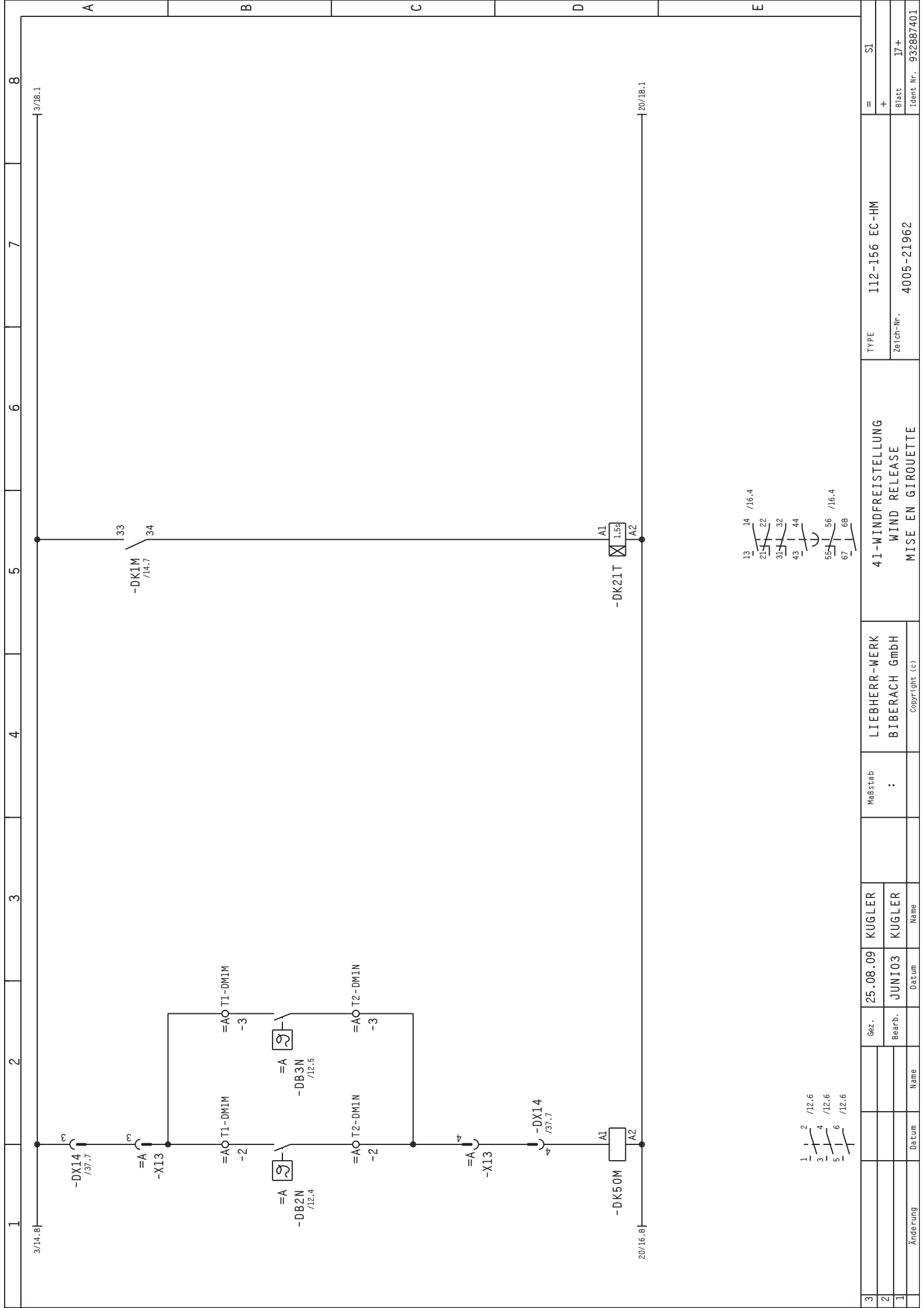

3				Gez.	25.08.09	KUGLER		Maßstab		LIEBHERR-WERK BIBERACH GmbH	TYPE	112-156 EC-HM
2				Bearb.	JUNIO3	KUGLER		:				
1	Änderung	Datum	Name								Zeich-Nr.	4005-21962
											Blatt	17+
											Ident. Nr.	932887401

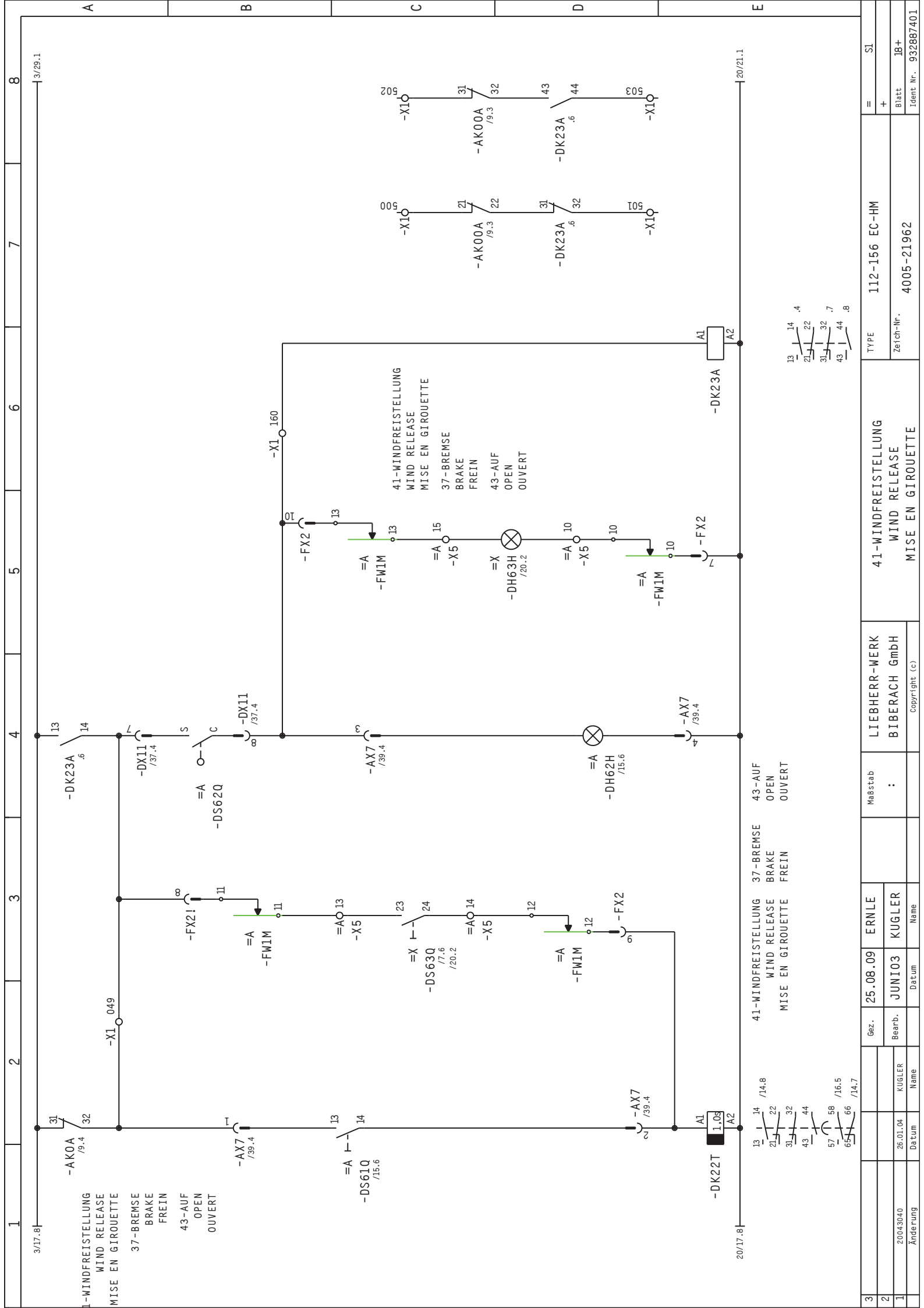

3		Gez.	25.08.09	ERNLE		Maßstab		LIEBHERR-WERK BIBERACH GmbH		41-WINDFREISTELLUNG WIND RELEASE MISE EN GIROQUETTE	112-156 EC-HM	TYPE	=	SI	
2		Bearb.	JUNIO3	KUGLER	:							+	Blatt	18+	
1	20043040	Datum		Name										Ident-Nr.	932887401
	Änderung	Datum		Name											

3/29.1

3/17.8

20/17.8

20/21.1

31

32

31

32

43

44

50

52

-AK0A /9.4

41-WINDFREISTELLUNG
WIND RELEASE
MISE EN GIROQUETTE

37-BREMSE
BRAKE
FREIN

43-AUF
OPEN
OUVERT

-AX7 /39.4

=A -DS61Q /15.6

-X1 /049

-FX2!

=A -FWIM

=A -X5

=X -DH63H /20.2

=A -X5

=A -X5

=A -FX2

-AX7 /39.4

-DK22T /1.09

-DK23A /14.8

13

14

21

22

31

32

43

44

57

58

65

66

16.5

14.7

41-WINDFREISTELLUNG
WIND RELEASE
MISE EN GIROQUETTE

37-BREMSE
BRAKE
FREIN

43-AUF
OPEN
OUVERT

-DK23A /15.6

-AX7 /39.4

-FX2

41-WINDFREISTELLUNG
WIND RELEASE
MISE EN GIROQUETTE

37-BREMSE
BRAKE
FREIN

43-AUF
OPEN
OUVERT

-DK23A /16.6

-X1 /160

-AX7 /39.4

-FX2

-DK23A /16.6

13

14

21

22

31

32

43

44

57

58

65

66

16.5

14.7

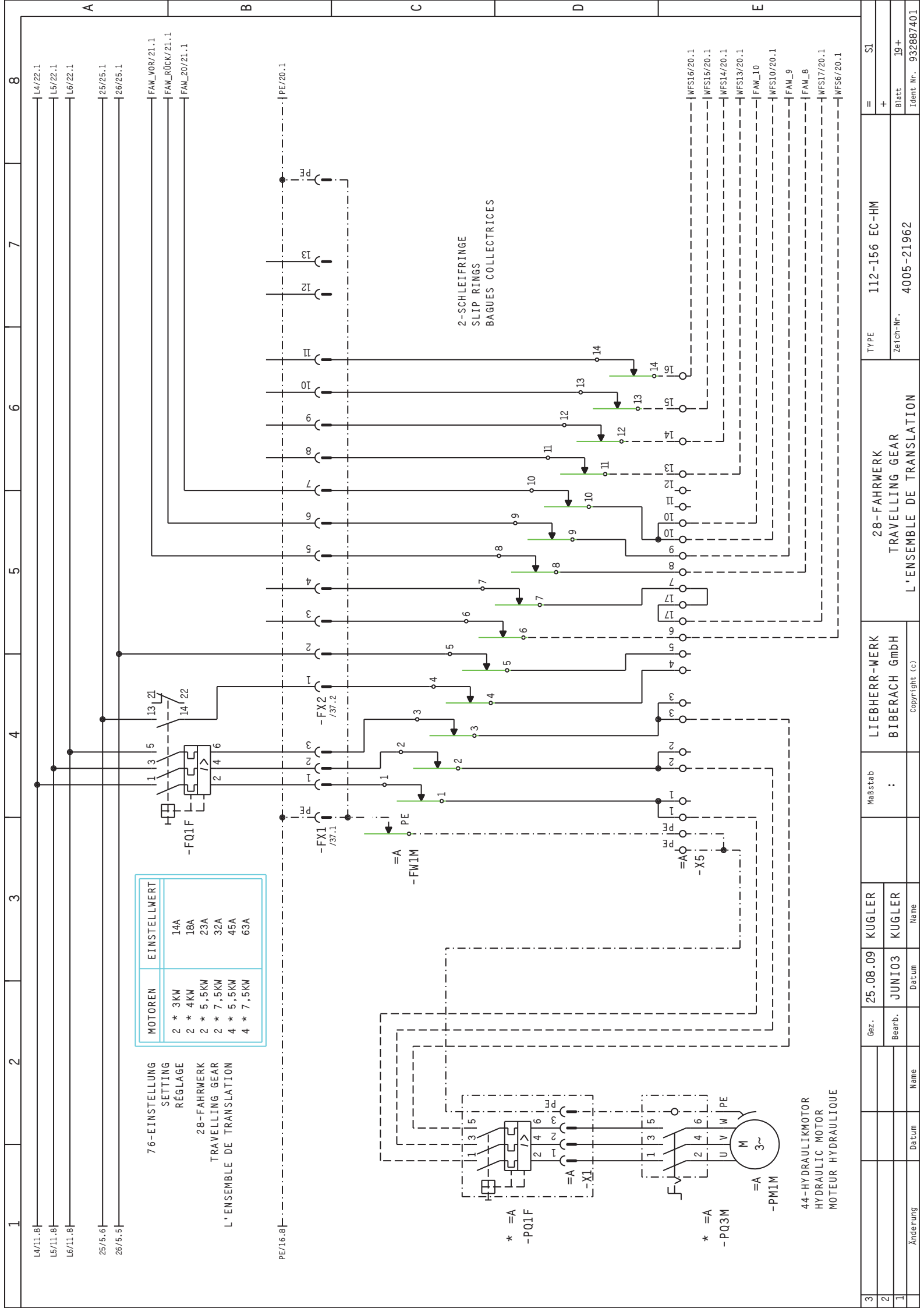

3	Änderung	Datum	Name	Gez.	25.08.09	KUGLER	Maßstab	1:1	LIEBHERR-WERK BIBERACH GmbH	TYPE	112-156 EC-HM	SI	
2				Bearb.	JUN103	KUGLER			28-FAHRWERK TRAVELLING GEAR L'ENSEMBLE DE TRANSLATION	Zeich-Nr.	4005-21962	+	
1										Blatt	19+	Ident. Nr.	932887401

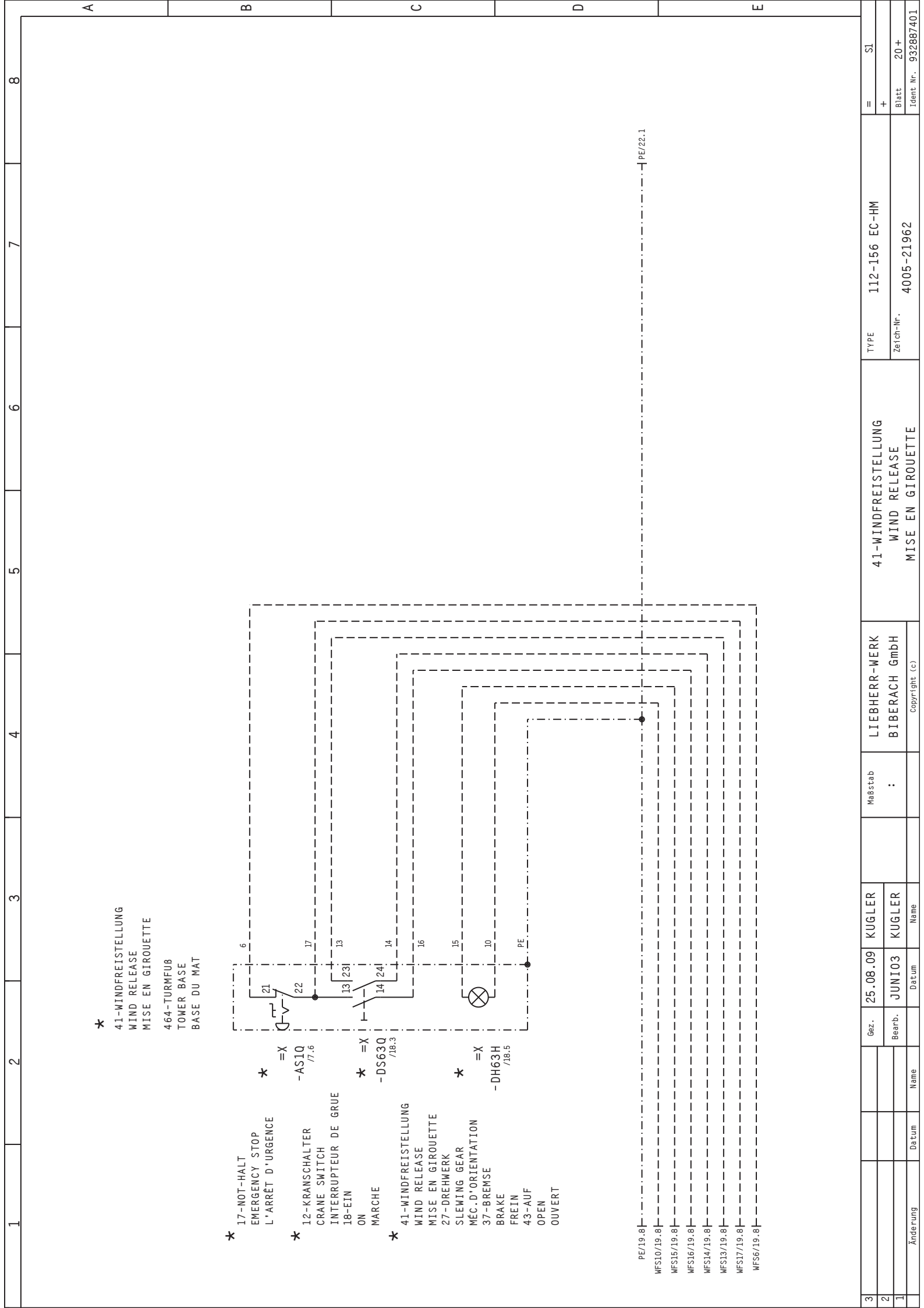

★
 41-WINDFREISTELLUNG
 WIND RELEASE
 MISE EN GIROQUETTE
 464-TURMFÜB
 TOWER BASE
 BASE DU MAT

- ★ 17-NOT-HALT
EMERGENCY STOP
L'ARRÊT D'URGENCE
- ★ 12-KRANSCHALTER
CRANE SWITCH
INTERRUPTEUR DE GRUE
- ★ 18-EIN
ON
MARCHE
- ★ 41-WINDFREISTELLUNG
WIND RELEASE
MISE EN GIROQUETTE
- ★ 27-DREHWERK
SLEWING GEAR
MÉC.-D'ORIENTATION
- ★ 37-BREMSE
BRAKE
FREIN
- ★ 43-AUF
OPEN
OUVERT

- ★ =X
-AS10
/17.6
- ★ =X
-DS630
/18.3
- ★ =X
-DH63H
/18.5

PE/19.8
 WFS10/19.8
 WFS15/19.8
 WFS16/19.8
 WFS14/19.8
 WFS13/19.8
 WFS17/19.8
 WFS6/19.8

3	Gez.	25.08.09	KUGLER	Maßstab	41-WINDFREISTELLUNG	TYPE	112-156 EC-HM	=	SI
2	Bearb.	JUNI03	KUGLER	:	WIND RELEASE	Zeich.-Nr.	4005-21962	+	Blatt
1	Name				MISE EN GIROQUETTE	Ident.-Nr.	932887401		20+
	Datum								Ident. Nr.
	Änderung								932887401

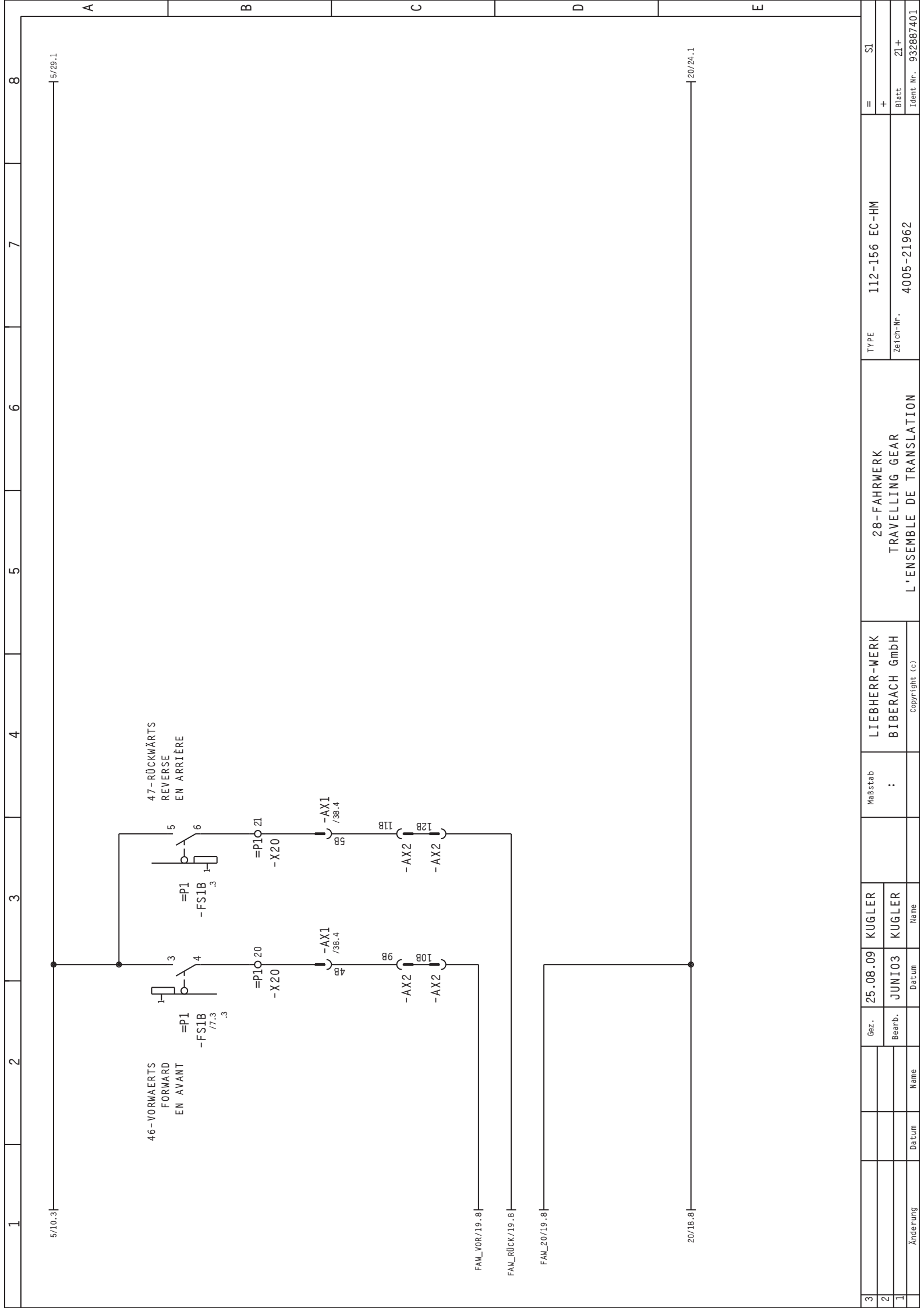

5/10.3 | 5/29.1

46 - VORWAERTS
FORWARD
EN AVANT

47 - RÜCKWÄRTS
REVERSE
EN ARRIÈRE

=P1
-FS1B
77.3

=P1
-FS1B
73

=PIÖ 20
-X20

=PIÖ 21
-X20

-AX1
/38.4

-AX1
/38.4

10B
-AX2

11B
-AX2

9B
-AX2

12B
-AX2

FAM_VOR/19.8

FAM_RÜCK/19.8

FAM_20/19.8

20/18.8 | 20/24.1

3	Gez.	25.08.09	KUGLER	Maßstab	LIEBHERR-WERK BIBERACH GmbH		TYPE	112-156 EC-HM	=	SI
2	Bearb.	JUNIO3	KUGLER	:	28-FAHRWERK TRAVELLING GEAR L'ENSEMBLE DE TRANSLATION		Zeich-Nr.	4005-21962	+	
1	Änderung	Datum	Name				Blatt	21+		
							Ident. Nr.	932887401		

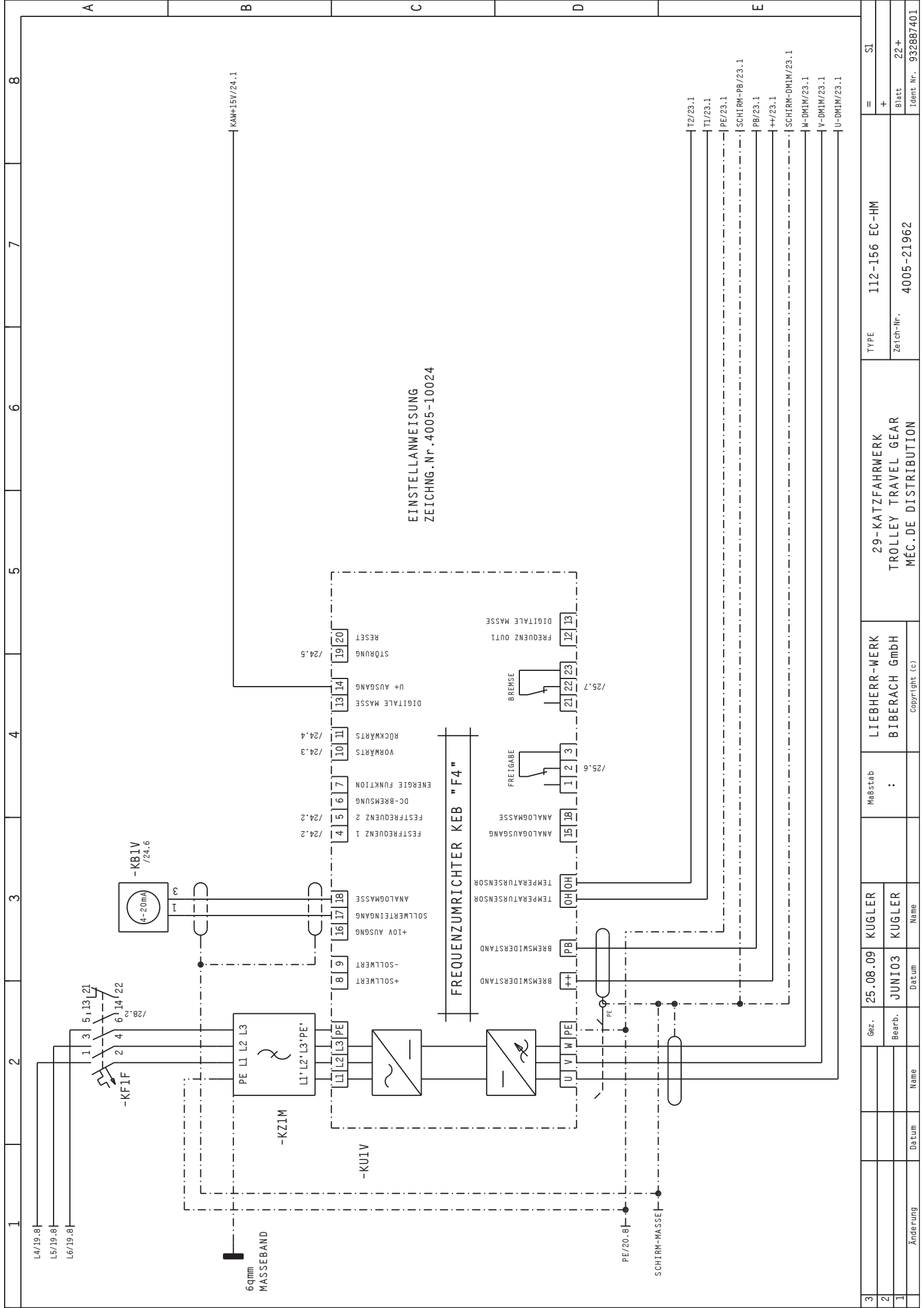

3	Gez.	25.08.09	KUGLER	Maßstab	1:1	29-KATZFAHRWERK	TYPE	112-156 EC-HM	SI
2	Bearb.	JUN103	KUGLER			TROLLEY TRAVEL GEAR		+	
1	Änderung					MÉC. DE DISTRIBUTION	Zeich.-Nr.	4005-21962	Blatt
							Ident.-Nr.	932887401	22+

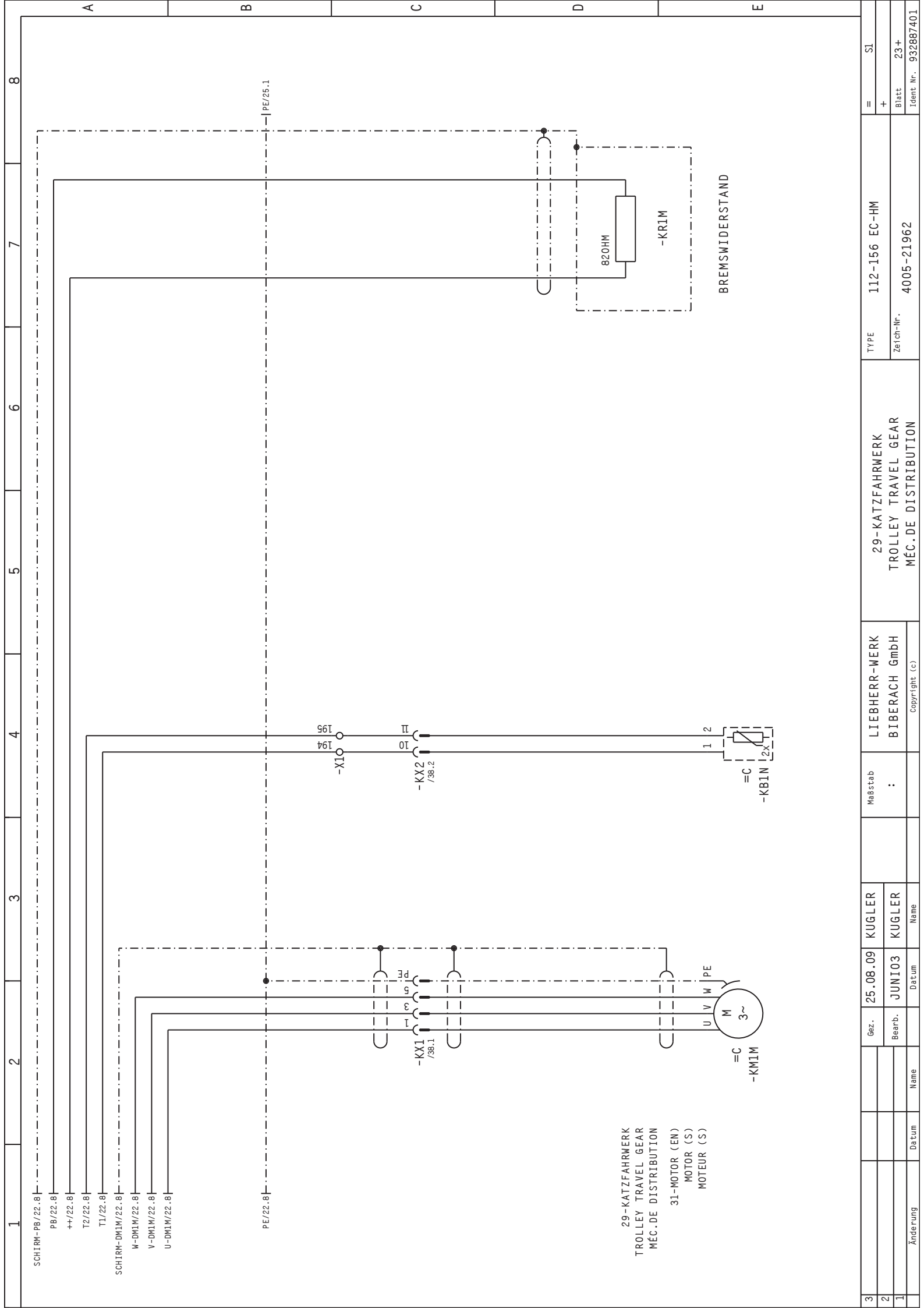

3		Gez.	25.08.09	KUGLER	Maßstab	LIEBHERR-WERK	TYPE	112-156 EC-HM	=	SI
2		Bearb.	JUN103	KUGLER	:	BIBERACH GmbH	Zeich-Nr.	4005-21962	+	
1							Ident-Nr.	932887401	Blatt	23+
	Änderung	Datum	Name	Datum	Name	Copyright (c)				Ident. Nr. 932887401

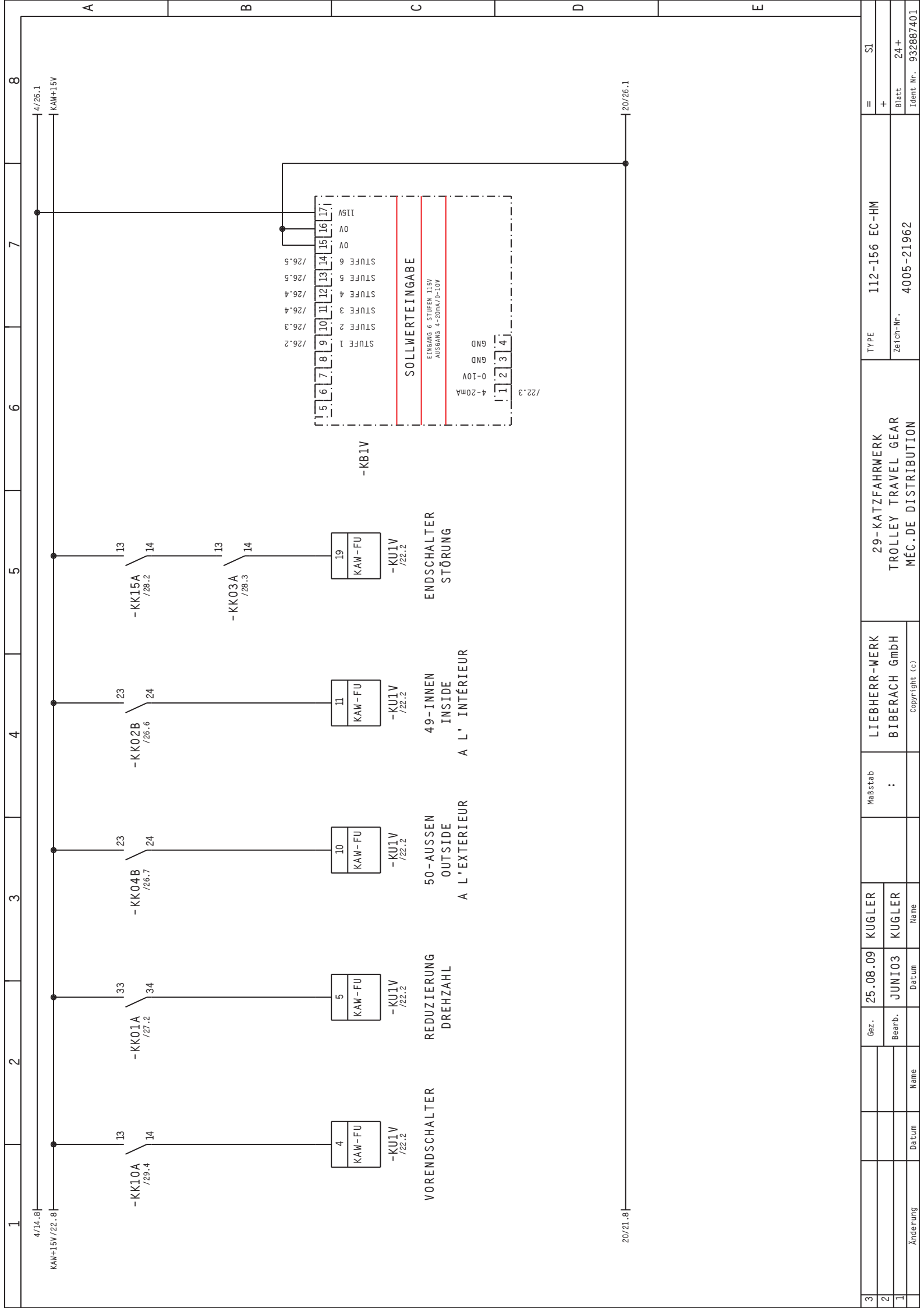

3	Gez.	25.08.09	KUGLER	Maßstab	29-KATZFAHRWERK		TYPE	112-156 EC-HM	=	SI
2	Bearb.	JUN103	KUGLER	:	TROLLEY TRAVEL GEAR			+		
1	Änderung		Name		MÉC.DE DISTRIBUTION		Zeich-Nr.	4005-21962	Blatt	24+
			Datum						Ident-Nr.	932887401

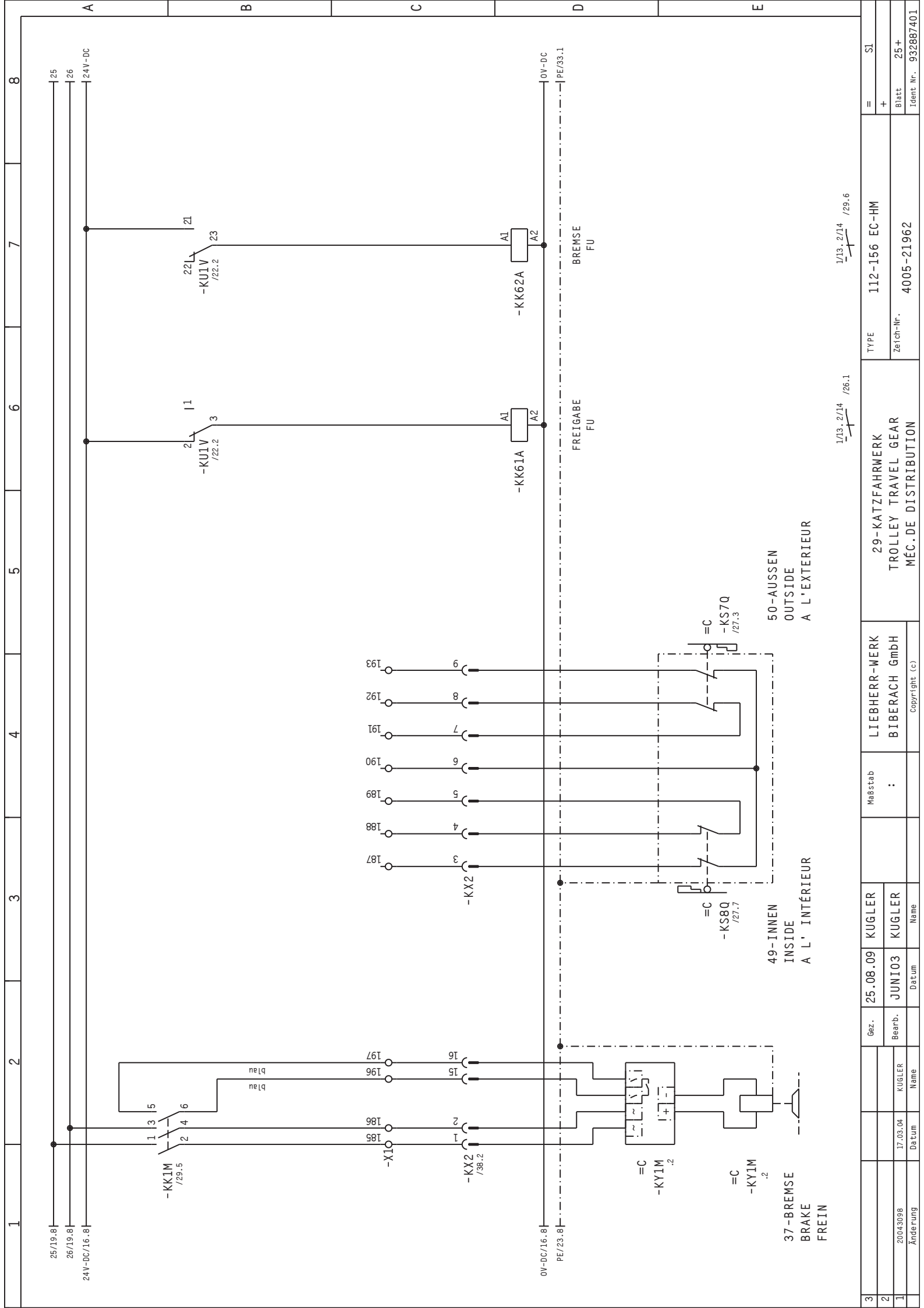

1/13, 2/14 /29.6

1/13, 2/14 /26.1

3	Gez.	25.08.09	KUGLER	Maßstab	LIEBHERR-WERK		TYPE	112-156 EC-HM
2	Bearb.	JUN103	KUGLER	:	BIBERACH GmbH			
1	Änderung	17.03.04	KUGLER	Name	Name		Zeich.-Nr.	4005-21962
				Datum	Datum		Blatt	25+
							Ident. Nr.	932887401

29-KATZFAHRWERK
TROLLEY TRAVEL GEAR
MÉC. DE DISTRIBUTION

50-AUSSEN
OUTSIDE
A L'EXTERIEUR

49-INNEN
INSIDE
A L'INTÉRIEUR

37-BREMSE
BRAKE
FREIN

SI
+
Blatt 25+
Ident. Nr. 932887401

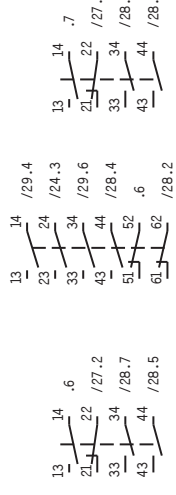
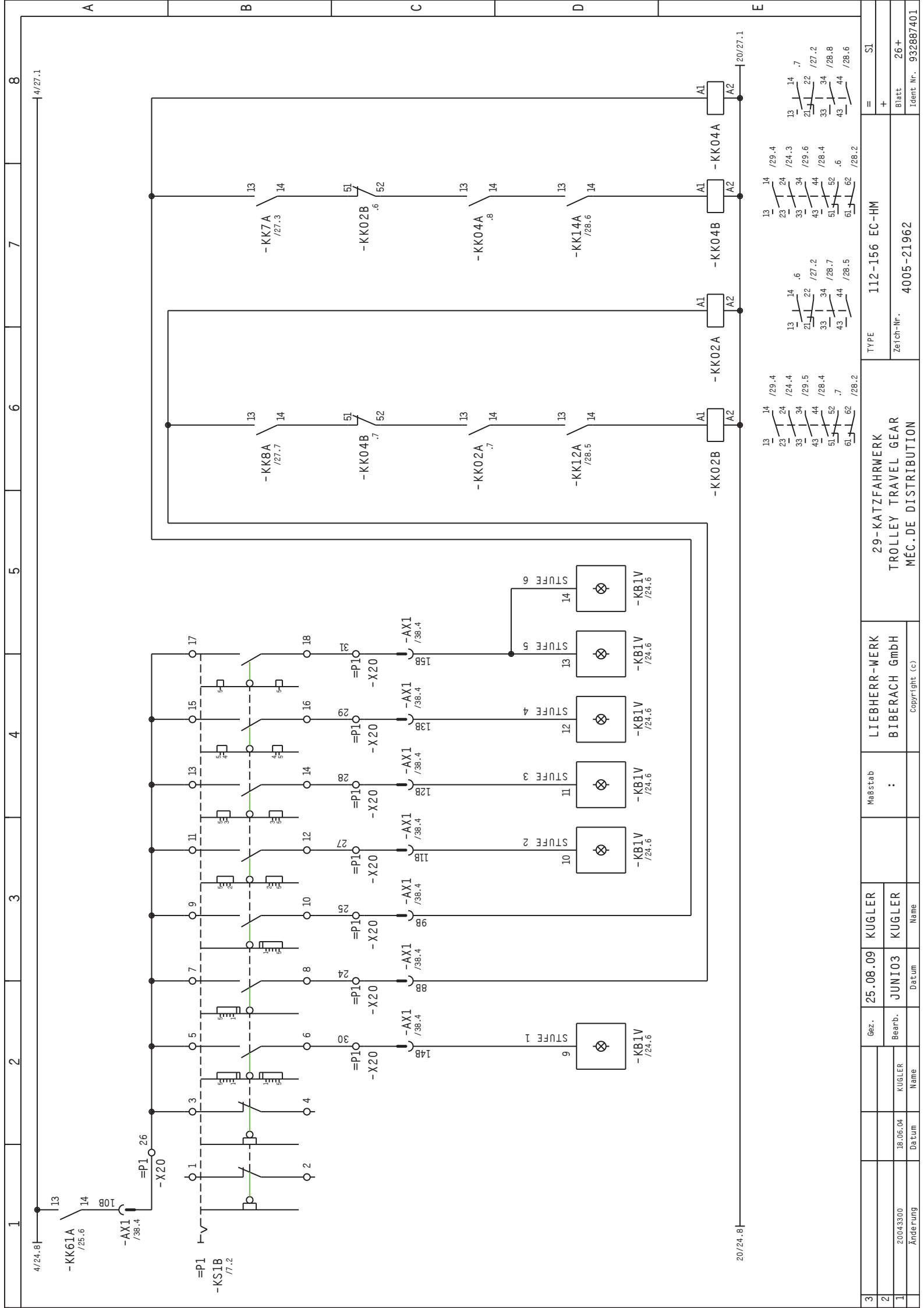

3	Gez.	25.08.09	KUGLER	Maßstab	LIEBHERR-WERK BIBERACH GmbH		TYPE	112-156 EC-HM	=	SI
2	Bearb.	JUNIO3	KUGLER	:			Zeich-Nr.	4005-21962	+	Blatt 26+
1	Änderung		Name				Ident-Nr.	932887401		Ident-Nr. 932887401

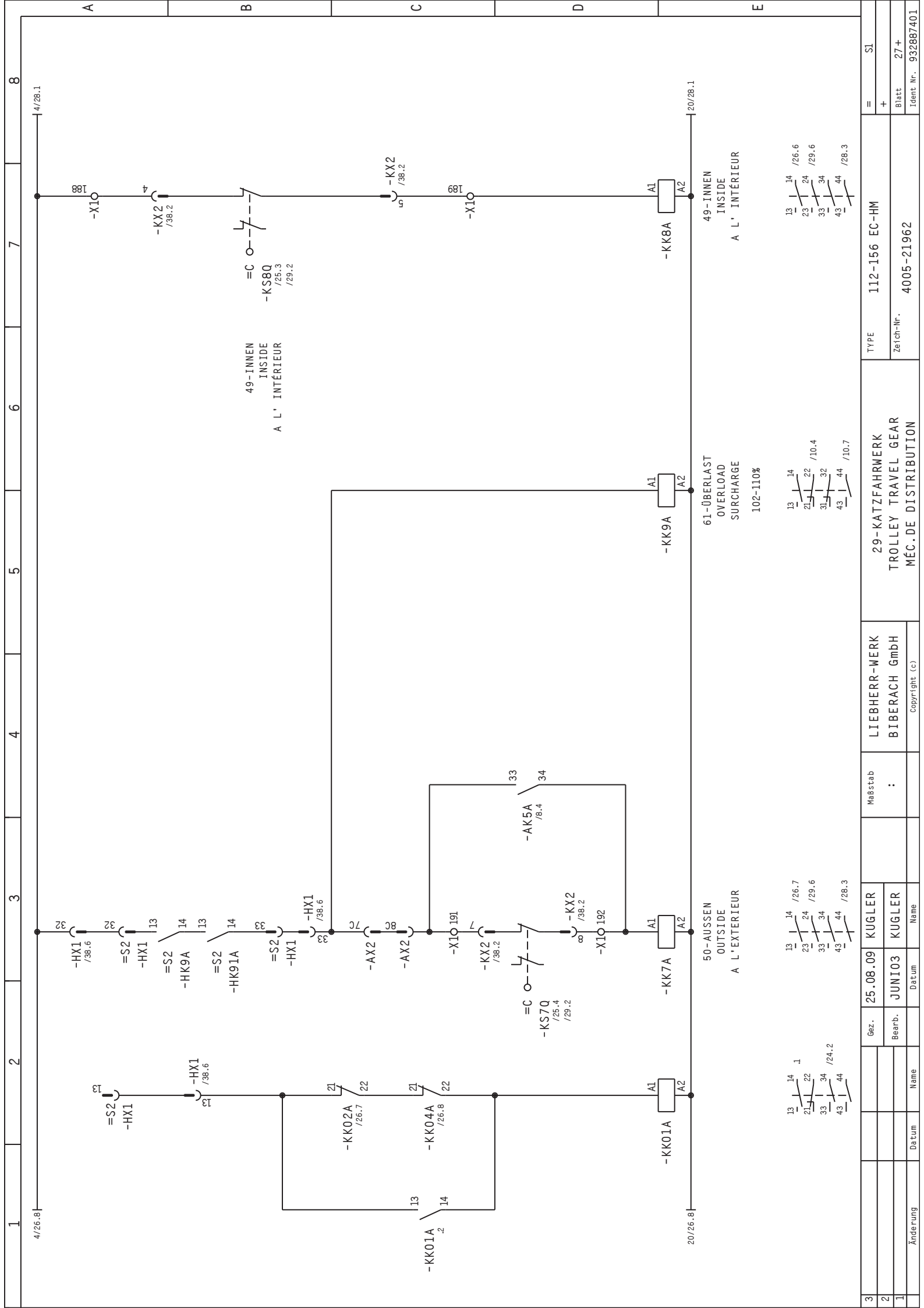

3	Gez.	25.08.09	KUGLER	Maßstab		TYPE	112-156 EC-HM	=	SI		
2	Bearb.	JUNIO3	KUGLER	:				+			
1	Änderung					29-KATZFAHRWERK TROLLEY TRAVEL GEAR MÉC. DE DISTRIBUTION	Zeich-Nr.	4005-21962	Blatt	27+	
										Ident. Nr.	932887401

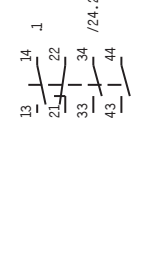
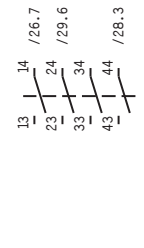
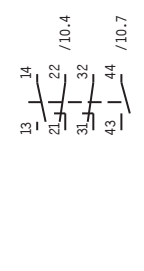

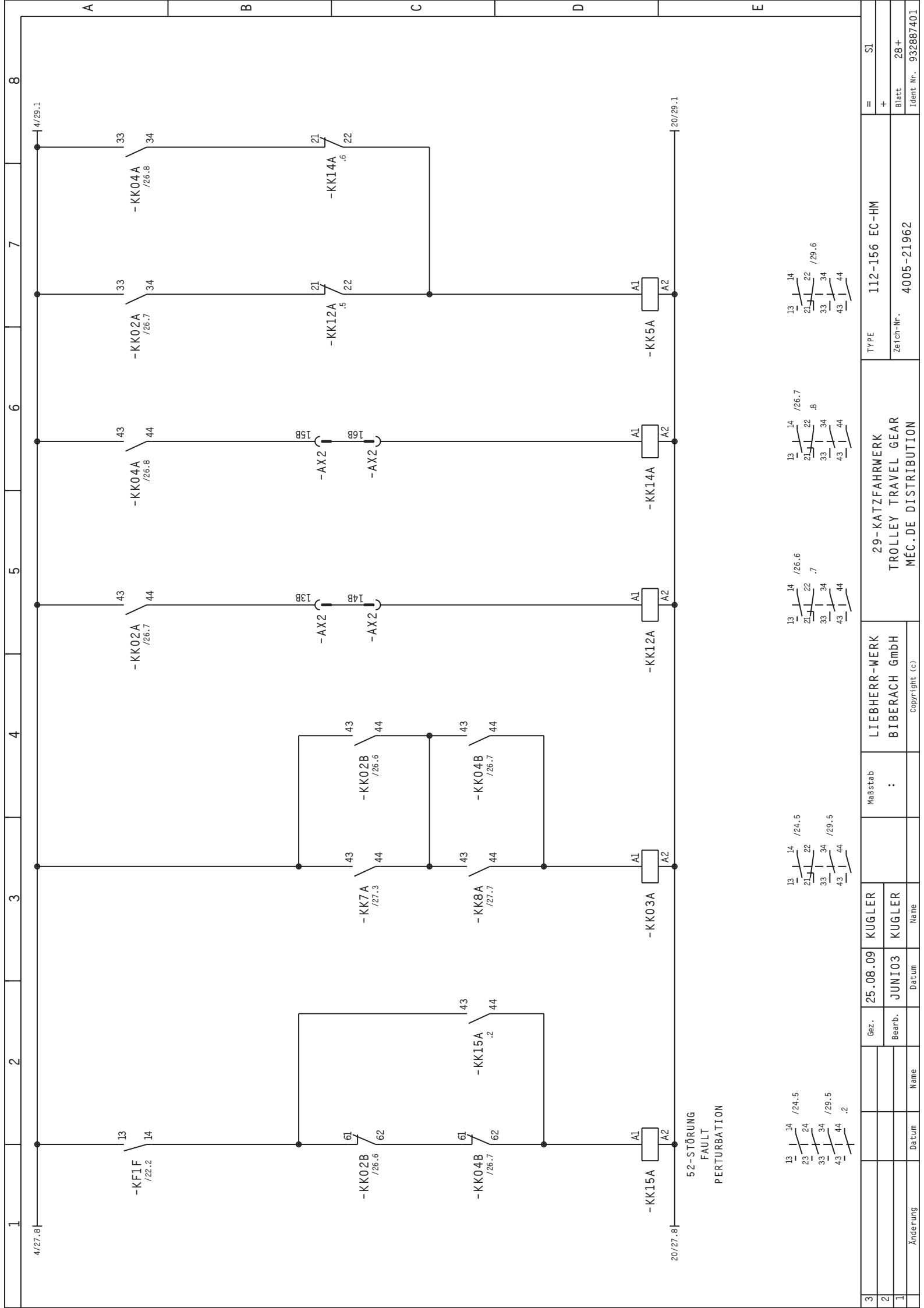

3	Änderung	Gez.	25.08.09	KUGLER	Maßstab	LIEBHERR-WERK BIBERACH GmbH	TYPE	112-156 EC-HM	=	SI
2		Bearb.	JUNIO3	KUGLER	:	29-KATZFAHRWERK TROLLEY TRAVEL GEAR MÉC.DE DISTRIBUTION			+	
1		Datum		Name			Zeich-Nr.	4005-21962	Blatt	28+
		Datum		Name					Ident. Nr.	932887401

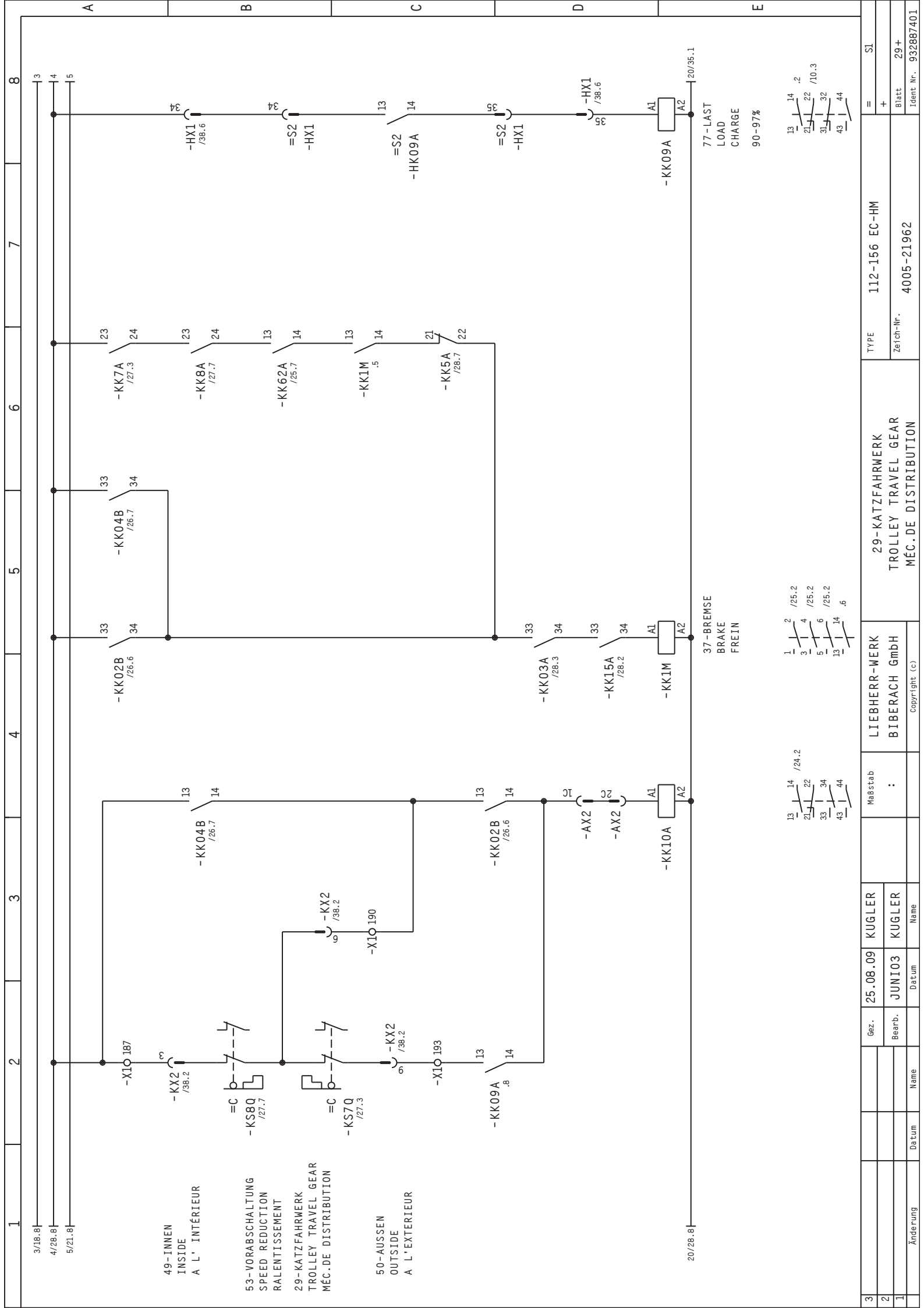

3/18.8]
4/28.8]
5/21.8]

49-INNEN
INSIDE
A L' INTÉRIEUR

53-VORABSCHALTUNG
SPEED REDUCTION
RALENTISSEMENT

29-KATZFAHRWERK
TROLLEY TRAVEL GEAR
MÉC.DE DISTRIBUTION

50-AUSSEN
OUTSIDE
A L' EXTERIEUR

37-BREMSE
BRAKE
FREIN

77-LAST
LOAD
CHARGE
90-97%

20/28.8]

37-BREMSE
BRAKE
FREIN

77-LAST
LOAD
CHARGE
90-97%

20/35.1

37-BREMSE
BRAKE
FREIN

77-LAST
LOAD
CHARGE
90-97%

20/35.1

37-BREMSE
BRAKE
FREIN

77-LAST
LOAD
CHARGE
90-97%

20/35.1

37-BREMSE
BRAKE
FREIN

77-LAST
LOAD
CHARGE
90-97%

20/35.1

37-BREMSE
BRAKE
FREIN

77-LAST
LOAD
CHARGE
90-97%

20/35.1

37-BREMSE
BRAKE
FREIN

77-LAST
LOAD
CHARGE
90-97%

20/35.1

37-BREMSE
BRAKE
FREIN

77-LAST
LOAD
CHARGE
90-97%

20/35.1

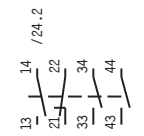
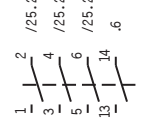

3	Gez.	25.08.09	KUGLER	Maßstab	LIEBHERR-WERK	TYPE	112-156 EC-HM
2	Bearb.	JUNIO3	KUGLER	:	BIBERACH GmbH	Zeich-Nr.	4005-21962
1	Name		Name		29-KATZFAHRWERK	Blatt	29+
	Datum		Datum		TROLLEY TRAVEL GEAR	Ident. Nr.	932887401
					MÉC.DE DISTRIBUTION		

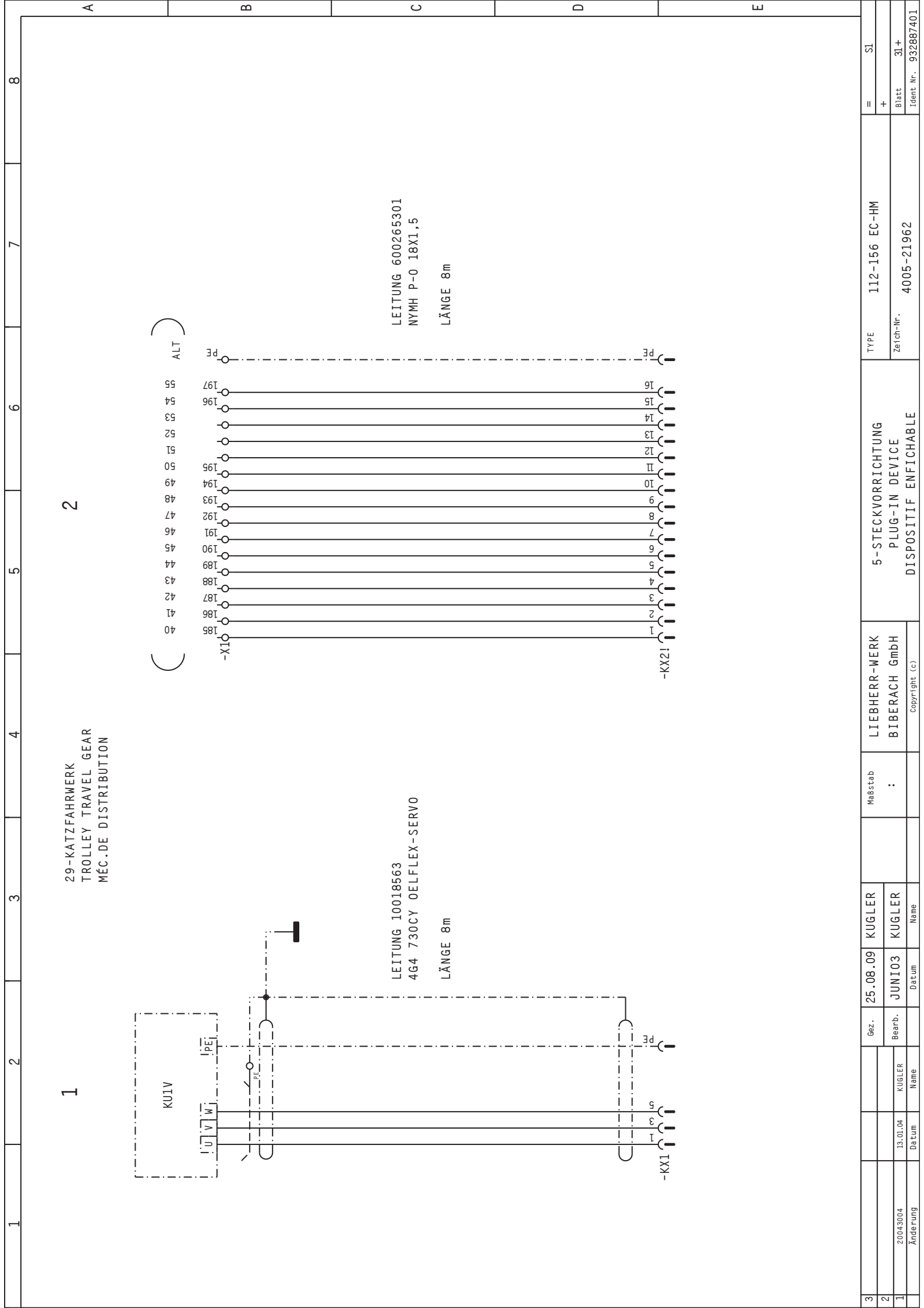

2

1

3	Gez.	25.08.09	KUGLER	Maßstab	LIEBHERR-WERK	TYPE	112-156 EC-HM	=	SI
2	Bearb.	JUNI03	KUGLER	:	BIBERACH GmbH	Zeich-Nr.	4005-21962	+	
1	Änderung	13.01.04	KUGLER			Blatt	31+		
			Name			Ident. Nr.	932887401		
			Datum			DISPOSITIF ENFICHABLE			
						Copyright (c)			

1 2 3 4 5 6 7 8

A

B

C

D

E

3			Gez.	25.08.09	KUGLER		Maßstab	LIEBHERR-WERK BIBERACH GmbH	5-STECKVORRICHTUNG PLUG-IN DEVICE DISPOSITIF ENFICHABLE	TYPE 112-156 EC-HM	= +	SI
2			Bearb.	JUN103	KUGLER		:			Zeich-Nr. 4005-21962	Blatt 32+	
1	Änderung	Datum	Name	Datum	Name							Ident. Nr. 932887401

Copyright (c)

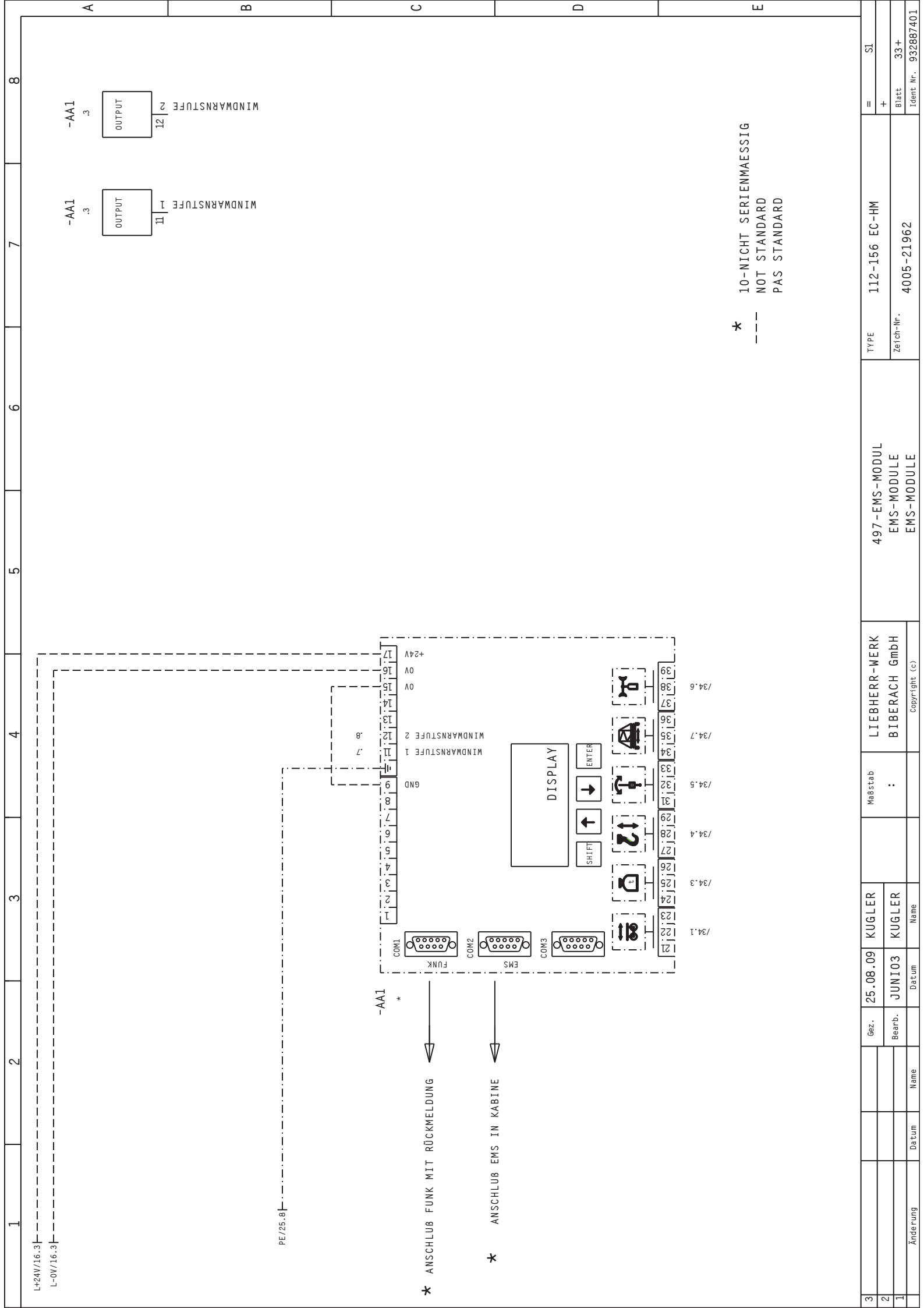

L+24V/16.3
L-0V/16.3

PE/25.8

-AA1 *

* ANSCHLUB FUNK MIT RÜCKMELDUNG

* ANSCHLUB EMS IN KABINE

* 10-NICHT SERIENMAESSIG
 --- NOT STANDARD
 PAS STANDARD

3			Gez.	25.08.09	KUGLER	Maßstab	LIEBHERR-WERK BIBERACH GmbH	497-EMS-MODUL EMS-MODULE EMS-MODULE	TYPE	112-156 EC-HM	=	SI
2			Bearb.	JUNIO3	KUGLER	:					+	
1	Änderung	Datum	Name	Datum	Name				Zeich-Nr.	4005-21962	Blatt	33+
									Ident. Nr.	932887401		

Copyright (c)

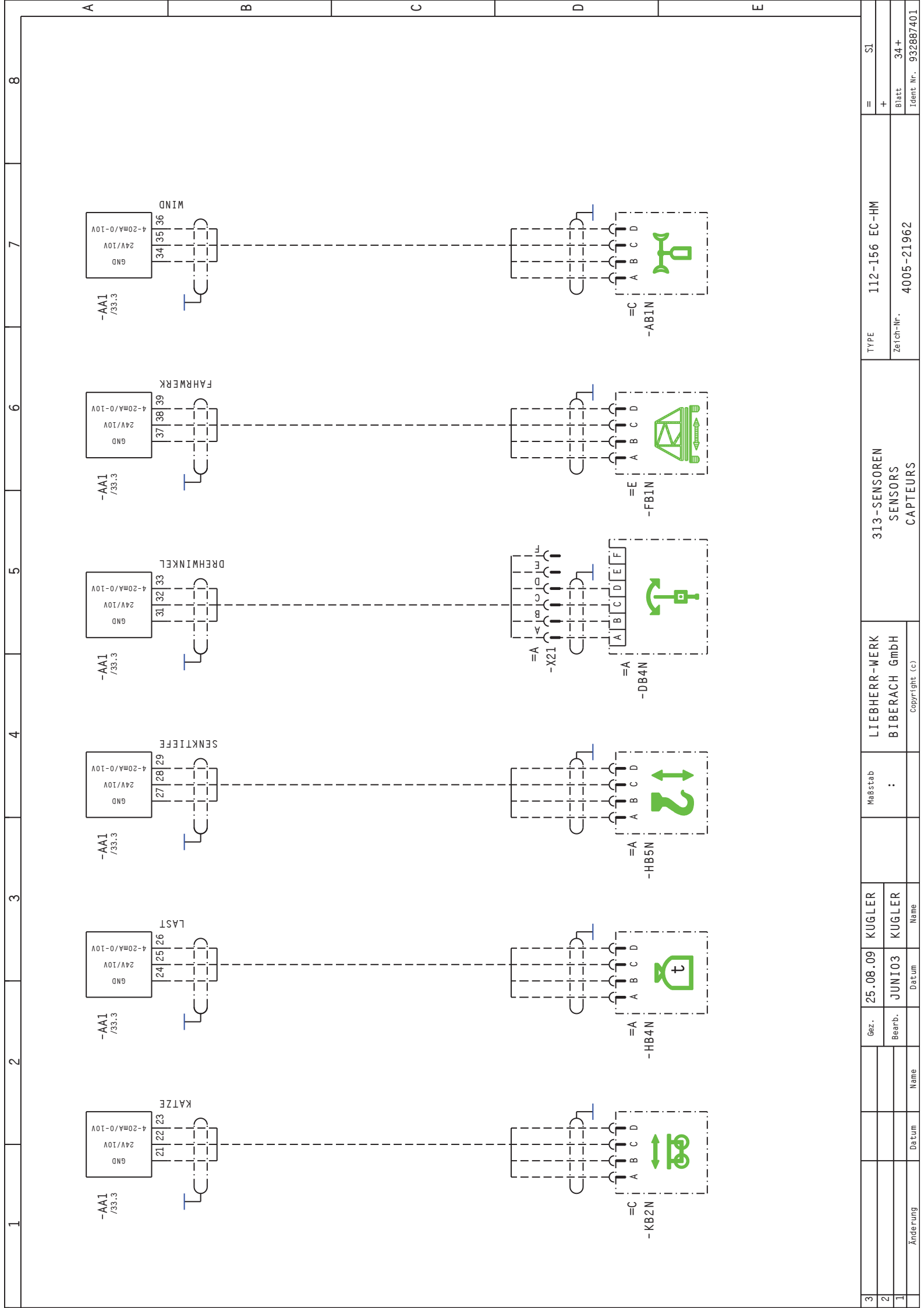

1 2 3 4 5 6 7 8

A

B

C

D

E

3		Gez.	25.08.09	KUGLER	Maßstab	LIEBHERR-WERK BIBERACH GmbH	313-SENSOREN SENSORS CAPTEURS	TYPE	112-156 EC-HM	=	SI
2		Bearb.	JUN103	KUGLER	:					+	
1								Zeich-Nr.	4005-21962	Blatt	34+
								Ident-Nr.	932887401		

Copyright (c)

3			Gez.		25.08.09	KUGLER	Maßstab :	LIEBHERR-WERK BIBERACH GmbH	5-STECKVORRICHTUNG PLUG-IN DEVICE DISPOSITIF ENFICHABLE		TYPE		112-156 EC-HM	=	SI
2			Bearb.		JUNIO3	KUGLER					Zeit-Nr. 4005-21962	Blaß			
1	Änderung		Datum					Copyright (c)			Ident. Nr.	932887401			

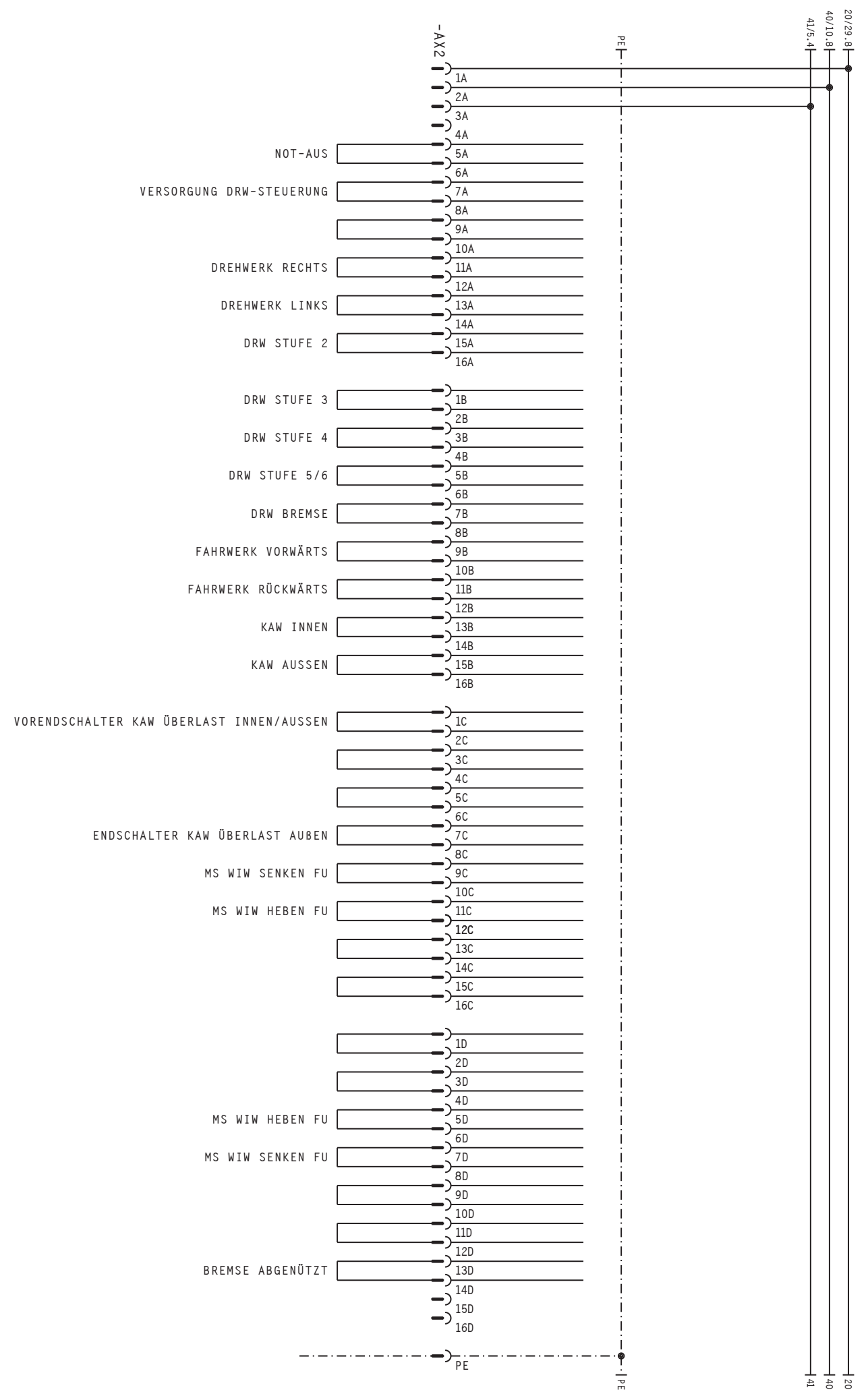

1	2	3	4	5	6	7	8					
A												
B												
C												
D												
E												
3		Gez.	25.08.09	KUGLER		Maßstab	LIEBHERR-WERK BIBERACH GmbH	5-STECKVORRICHTUNG PLUG-IN DEVICE DISPOSITIF ENFICHABLE	TYPE	112-156 EC-HM	=	SI
2		Bearb.	JUNI03	KUGLER		:					+	
1		Name	Datum	Name					Zeich-Nr.	4005-21962	Blatt	36+
		Name	Datum	Name					Ident. Nr.	932887401		

1	2	3	4	5	6	7	8																																								
1	2	3	4	5	6	7	8																																								
A																																															
<p>-FX1</p> <p>SCHLEIFRINGKÖRPER FAN+KLETTHERYDRAULIK</p>																																															
B																																															
<p>-FX2</p> <p>DATENSCHLEIFRINGE WINDFREISTELLUNG TURMFUß</p>																																															
C																																															
<p>-DX11</p> <p>BREMSE DREHWERK WFS DRW 1</p>																																															
D																																															
<p>-DX12</p> <p>FREMDLÜFTER DRW 1</p>																																															
E																																															
<p>-DX13</p> <p>DRW MOTOR 1</p>																																															
<p>-DX14</p> <p>MOTORVOLLSCHUTZ DRW 1</p>																																															
<table border="1"> <tr> <td>3</td> <td>Gez.</td> <td>25.08.09</td> <td>KUGLER</td> <td>Maßstab</td> <td>LIEBHERR-WERK</td> <td>TYPE</td> <td>112-156 EC-HM</td> <td>=</td> <td>SI</td> </tr> <tr> <td>2</td> <td>Bearb.</td> <td>JUNIO3</td> <td>KUGLER</td> <td>:</td> <td>BIBERACH GmbH</td> <td colspan="2">5-STECKVORRICHTUNG PLUG-IN DEVICE</td> <td>+</td> <td></td> </tr> <tr> <td>1</td> <td>Änderung</td> <td>Datum</td> <td>Name</td> <td></td> <td></td> <td colspan="2">DISPOSITIF ENFICHABLE</td> <td>Blatt</td> <td>37+</td> </tr> <tr> <td></td> <td></td> <td></td> <td></td> <td></td> <td></td> <td colspan="2"></td> <td>Ident. Nr.</td> <td>932887401</td> </tr> </table>								3	Gez.	25.08.09	KUGLER	Maßstab	LIEBHERR-WERK	TYPE	112-156 EC-HM	=	SI	2	Bearb.	JUNIO3	KUGLER	:	BIBERACH GmbH	5-STECKVORRICHTUNG PLUG-IN DEVICE		+		1	Änderung	Datum	Name			DISPOSITIF ENFICHABLE		Blatt	37+									Ident. Nr.	932887401
3	Gez.	25.08.09	KUGLER	Maßstab	LIEBHERR-WERK	TYPE	112-156 EC-HM	=	SI																																						
2	Bearb.	JUNIO3	KUGLER	:	BIBERACH GmbH	5-STECKVORRICHTUNG PLUG-IN DEVICE		+																																							
1	Änderung	Datum	Name			DISPOSITIF ENFICHABLE		Blatt	37+																																						
								Ident. Nr.	932887401																																						

1	2	3	4	5	6	7	8
A							
9							
-KX1							
10							
-KX2							
11							
-AX1							
12							
-HX1							
C							
KAW							
MOTOR							
FÜHLER+BREMSE							
D							
KAW							
MOTOR							
FÜHLER+BREMSE							
E							
STEUERSTAND P1							
5-STECKVORRICHTUNG PLUG-IN DEVICE DISPOSITIF ENFICHABLE							
LIEBHERR-WERK BIBERACH GmbH							
Maßstab :							
TYPE 112-156 EC-HM							
Zeich.-Nr. 4005-21962							
Blatt 38+							
Ident. Nr. 932887401							
Gez. 25.08.09 KUGLER							
Bearb. JUNI03 KUGLER							
Änderung Datum Name							
Datum Name							
Copyright (c)							
= SI							
+							

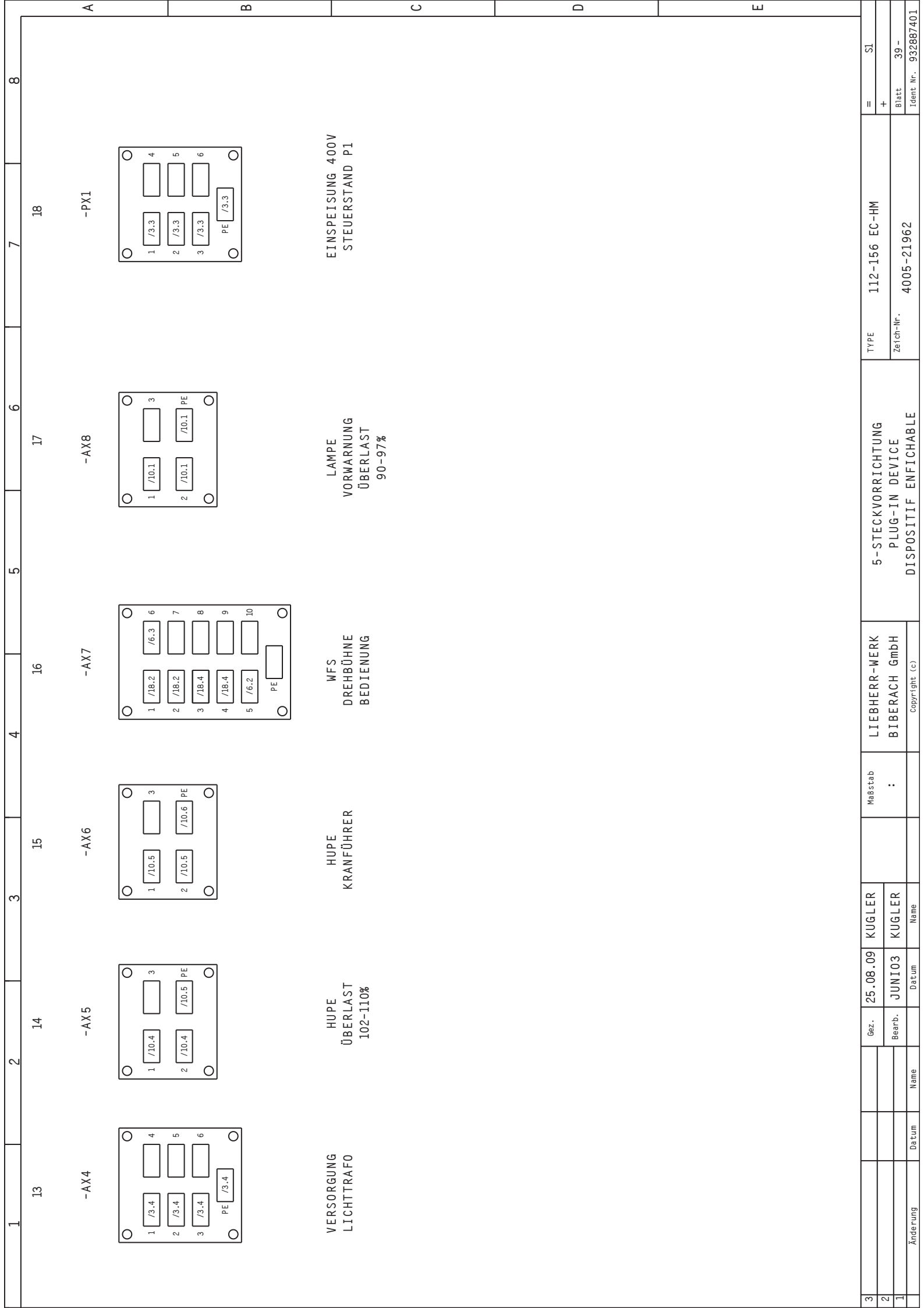

3		Gez.	25.08.09	KUGLER	KUGLER	Maßstab	LIEBHERR-WERK	TYPE	112-156 EC-HM	=	SI
2		Bearb.	JUNIO3	KUGLER	KUGLER	:	BIBERACH GmbH	5-STECKVORRICHTUNG PLUG-IN DEVICE		+	
1		Name	Datum	Name	Name			Zeich-Nr. 4005-21962		Blatt	39 -
	Änderung	Datum						DISPOSITIF ENFICHABLE		Ident. Nr.	932887401

Copyright (c)