

59-MOMENTEN  
MOMENT  
61-ÜBERLAST  
OVERLOAD

60-KONSTANTE  
CONSTANT  
61-ÜBERLAST  
OVERLOAD  
62-GANG 1  
GEAR

61-ÜBERLAST  
OVERLOAD

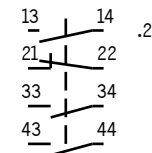
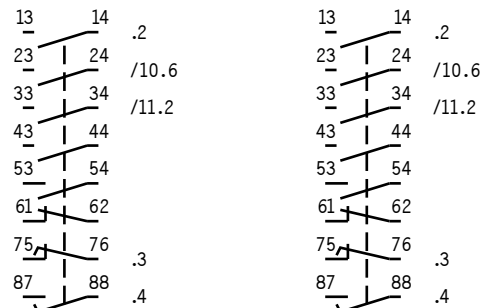

3			Gez.	31.08.09		Maßstab	LIEBHERR-WERK	61-ÜBERLAST OVERLOAD	TYPE	EC-H	=	S2	
2			Bearb.	17.03.93	ELLINGER	:	BIBERACH GmbH		Zeich-Nr.	4005-21534	+	Blatt	3+
1	Änderung	Datum	Name	Datum	Name		Copyright (c)					Ident Nr.	



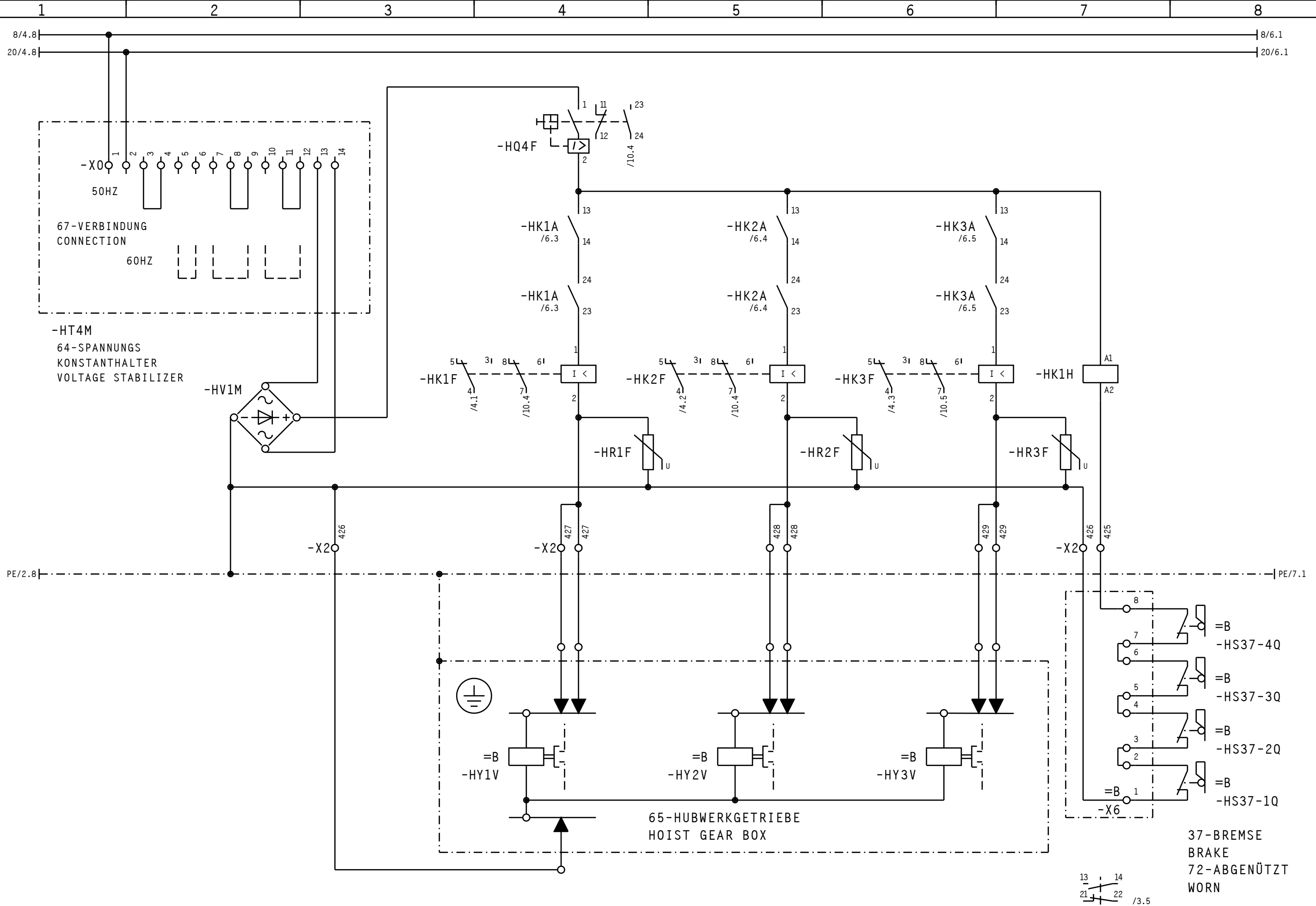

3			Gez.	31.08.09		Maßstab	LIEBHERR-WERK	65-HUBWERKGETRIEBE HOIST GEAR BOX	TYPE	EC-H	=	S2	
2			Bearb.	17.03.93	ELLINGER	:	BIBERACH GmbH		Zeich-Nr.	4005-21534	+	Blatt	5+
1	Änderung	Datum	Name	Datum	Name		Copyright (c)					Ident Nr.	











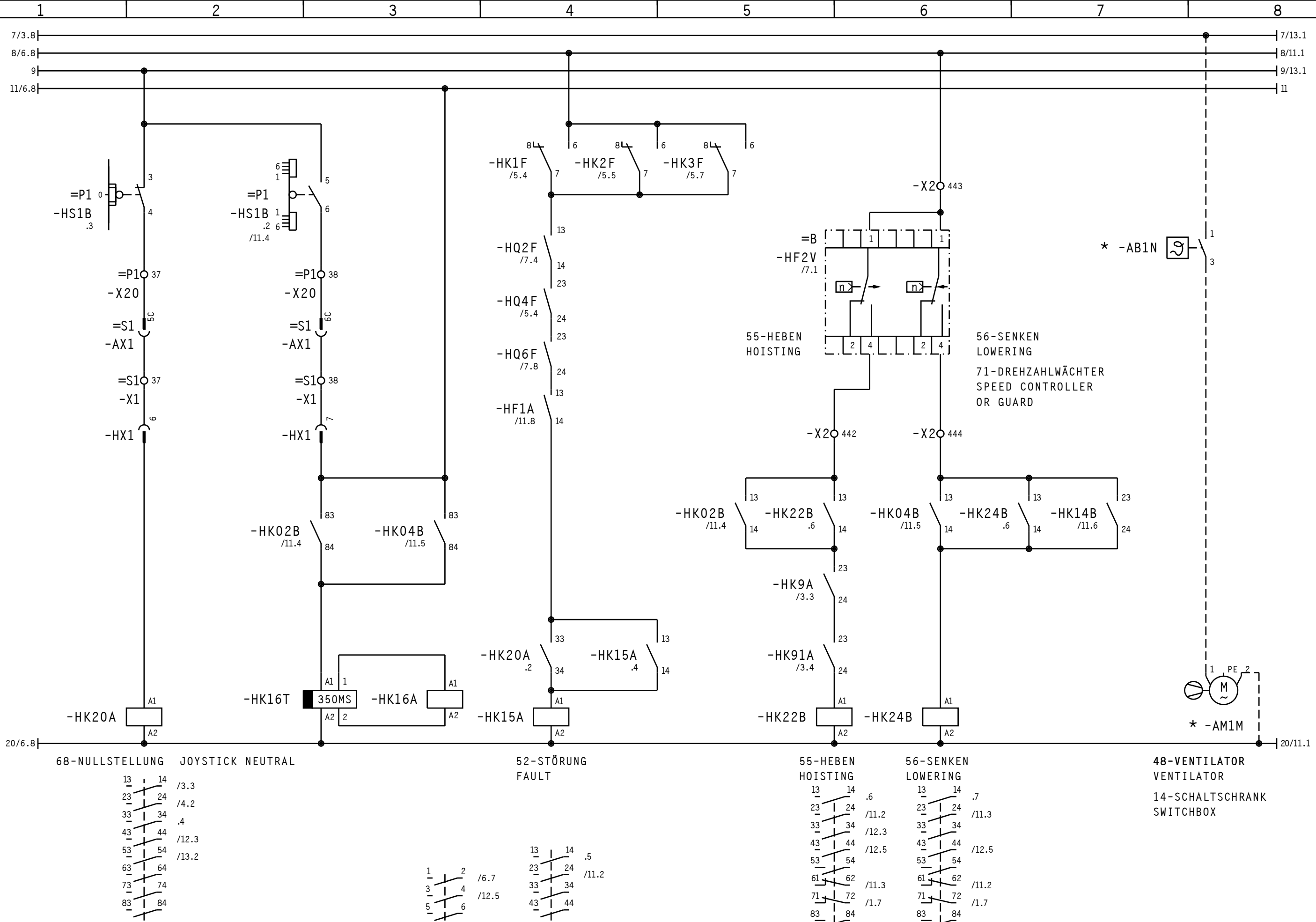

3			Gez.	31.08.09		Maßstab	LIEBHERR-WERK	30-HUBWERK HOIST GEAR	TYPE	EC-H	=	S2	
2			Bearb.	17.03.93	ELLINGER	:	BIBERACH GmbH		Zeich-Nr.	4005-21534	+	Blatt	10+
1	Änderung	Datum	Name	Datum	Name		Copyright (c)					Ident Nr.	

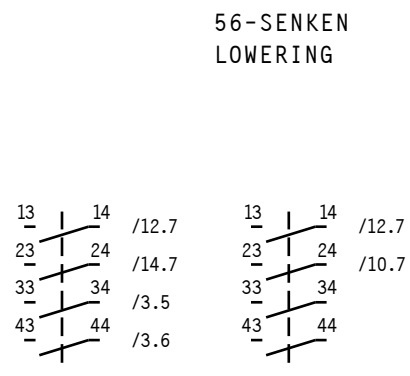
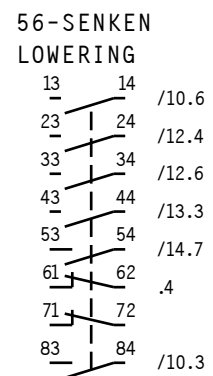
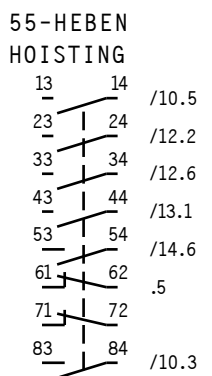
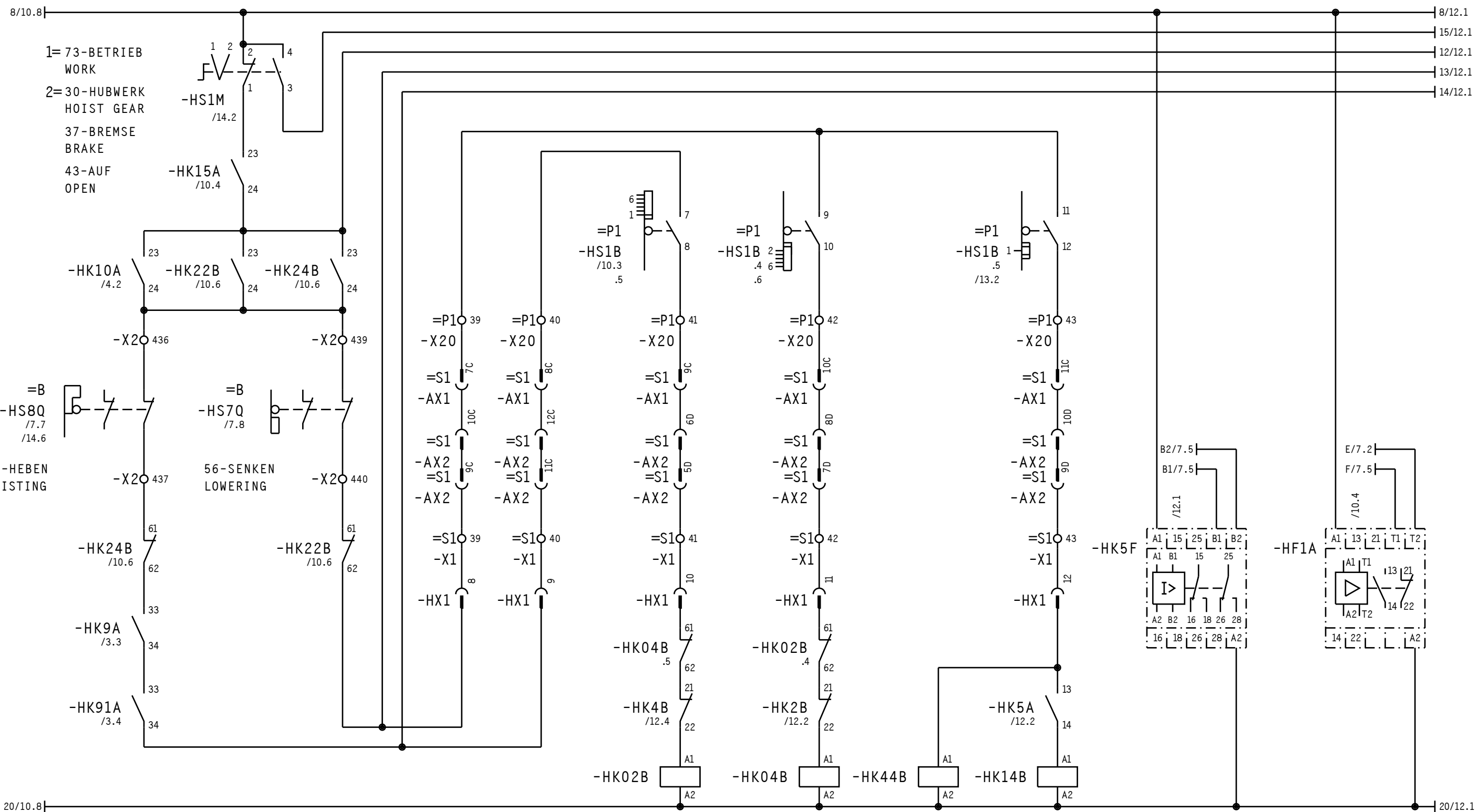

3			Gez.	31.08.09		Maßstab	LIEBHERR-WERK	30-HUBWERK HOIST GEAR	TYPE	EC-H	=	S2	
2			Bearb.	17.03.93	ELLINGER	:	BIBERACH GmbH		Zeich-Nr.	4005-21534	+	Blatt	11+
1	Änderung	Datum	Name	Datum	Name		Copyright (c)			4005-21534		Ident Nr.	

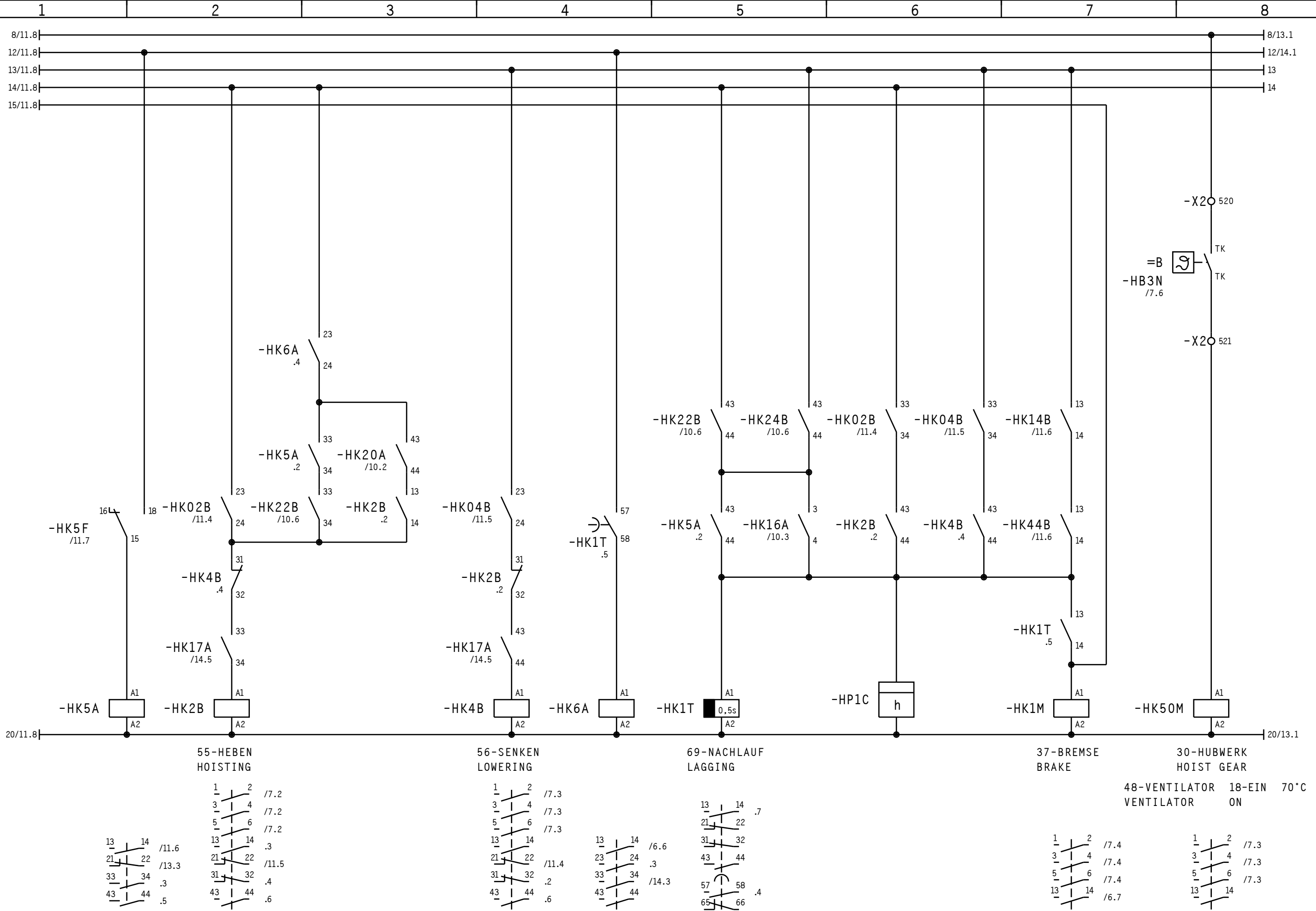

3			Gez.	31.08.09		Maßstab	LIEBHERR-WERK	30-HUBWERK HOIST GEAR	TYPE	EC-H	=	S2	
2			Bearb.	17.03.93	ELLINGER	:	BIBERACH GmbH		Zeich-Nr.	4005-21534	+	Blatt	12+
1	Änderung	Datum	Name	Datum	Name		Copyright (c)					Ident Nr.	

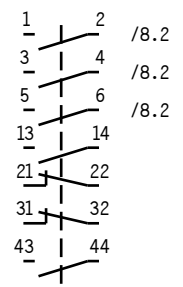
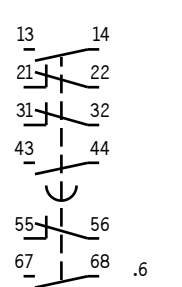
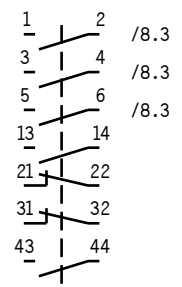
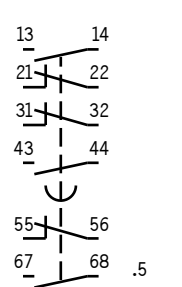
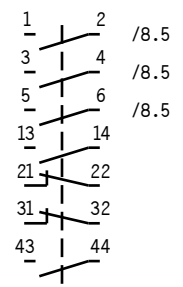
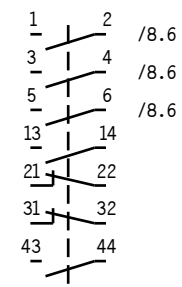
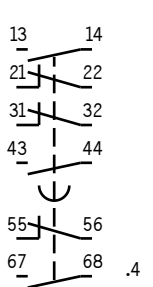
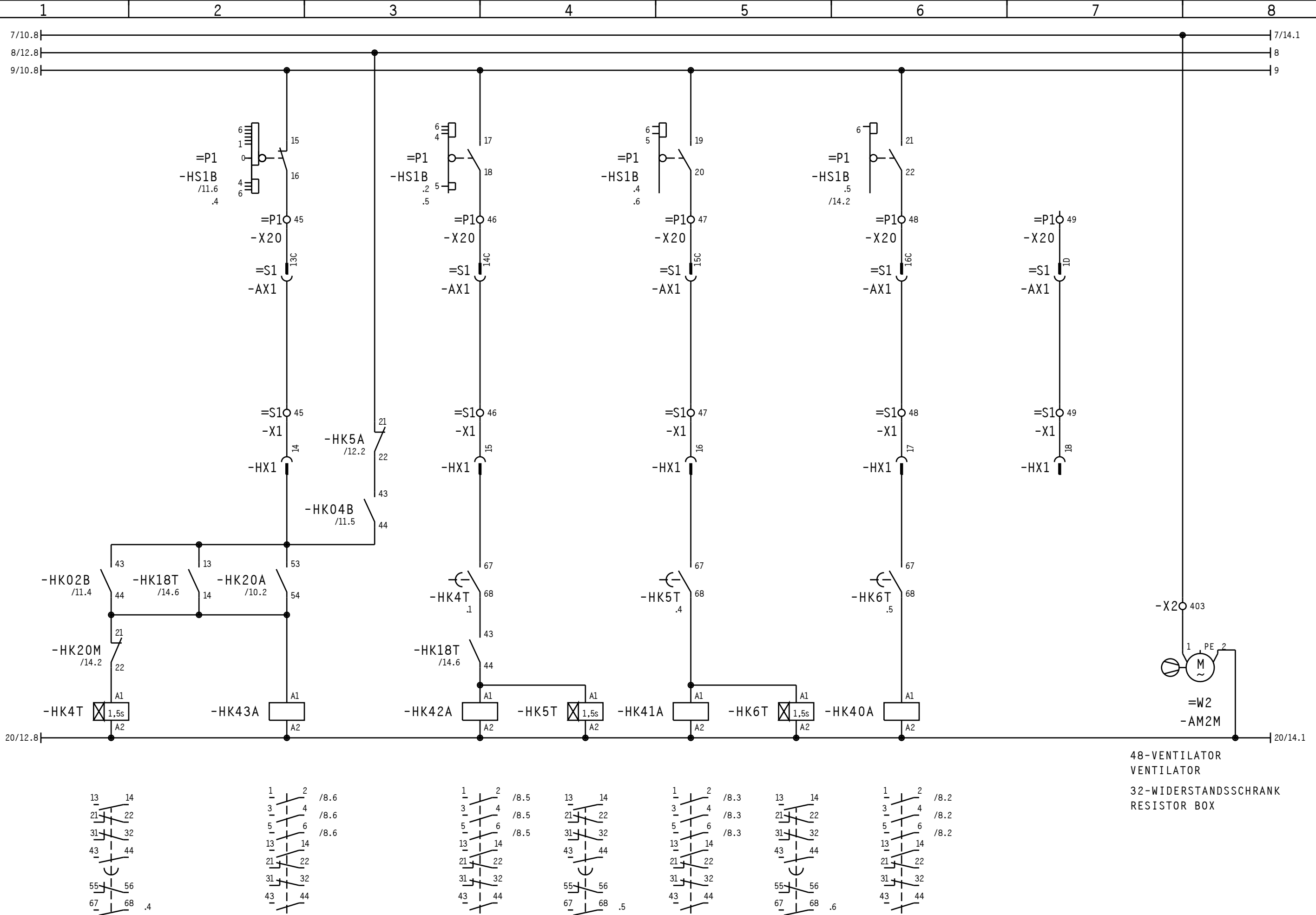

48-VENTILATOR  
VENTILATOR  
32-WIDERSTANDSSCHRANK  
RESISTOR BOX

3			Gez.	31.08.09		Maßstab	LIEBHERR-WERK	30-HUBWERK HOIST GEAR	TYPE	EC-H	=	S2	
2			Bearb.	17.03.93	ELLINGER	:	BIBERACH GmbH		Zeich-Nr.	4005-21534	+	Blatt	13+
1	Änderung	Datum	Name	Datum	Name		Copyright (c)					Ident Nr.	

