

SCHALTSCHRANK-TURMDREHKRAN F.35K
 ARMADIO DI COMANDO DELLA F.35K
 GRU GIREVOLE

SCHALTPLAN NR.	4005-21498	SCHEMA ELETTRICO N.
STÜCKLISTE NR.	4005-62050	DISTINTA PEZZI N.
GERÄTEPLAN NR.	4005-81592	SCHEMA SISTEMAZIONE ATTREZZI N.
SACH/INDENT NR.	611168501	N.INDENT (N.PEZZO)
BESCHRIFTUNG NR.	4005-9131	ISCRIZIONE N.

BLATT

JNHALTSVERZEICHNIS	1	INDICE
EINSPEISUNG	2+3	ALIMENTAZIONE
STEUERUNG	4	SISTEMA DI COMANDO
HORN	5	AVVISATORE ACUSTICO
DREHWERK	6-8	MECCANISMO DI ROTAZIONE
KATZ+DREHBEGRENZUNG	9	LIMITAZIONE CARRELLO+ROTAZIONE
FAHRWERK	10+11	MECCANISMO DI TRASLAZIONE
KATZFAHRWERK	12-15	MECCANISMO DI TRASLAZIONE CARRELLO
101-HILFSHUBWERK	12, 16+17	MECCANISMO DI SOLLEVAMENTO AUSILIARIO
ÜBERLAST	18+19	SOVRACCARICO
HUBWERK	20-24	MECCANISMO DI SOLLEVAMENTO
SICHERHEITSEINRICHTUNG	25	ATTREZZATURE DI SICUREZZA
STEUERPULT	26+27	BANCO DI COMANDO
STECKDOSE	28	CONNETTORE AD INNESTO

ÄNDERUNG:
 AUF BLATT 23 STROMPFAD 4/5
 LINIE VON KLEMME X1/412
 AUF KONTAKT JS1M KLEMME 22
 GEÄNDERT 30.06.92

SCHÜTZ KONTAKT JK21A KLEMME
 83/84 AUF BLATT 24 STROMPFAD
 8 EINGEZ. JULI 92

3			Gez.	31.08.09	HUBER		Maßstab	LIEBHERR-WERK	INHALTSVERZEICHNIS	TYPE	35K ITALIEN	=	S1
2						:	BIBERACH GmbH	INDICE				+	
1			Bearb.								Zeich-Nr.	4005-21498	Blatt
	Änderung	Datum	Name	Datum	Name		Copyright (c)					Ident Nr.	611168501

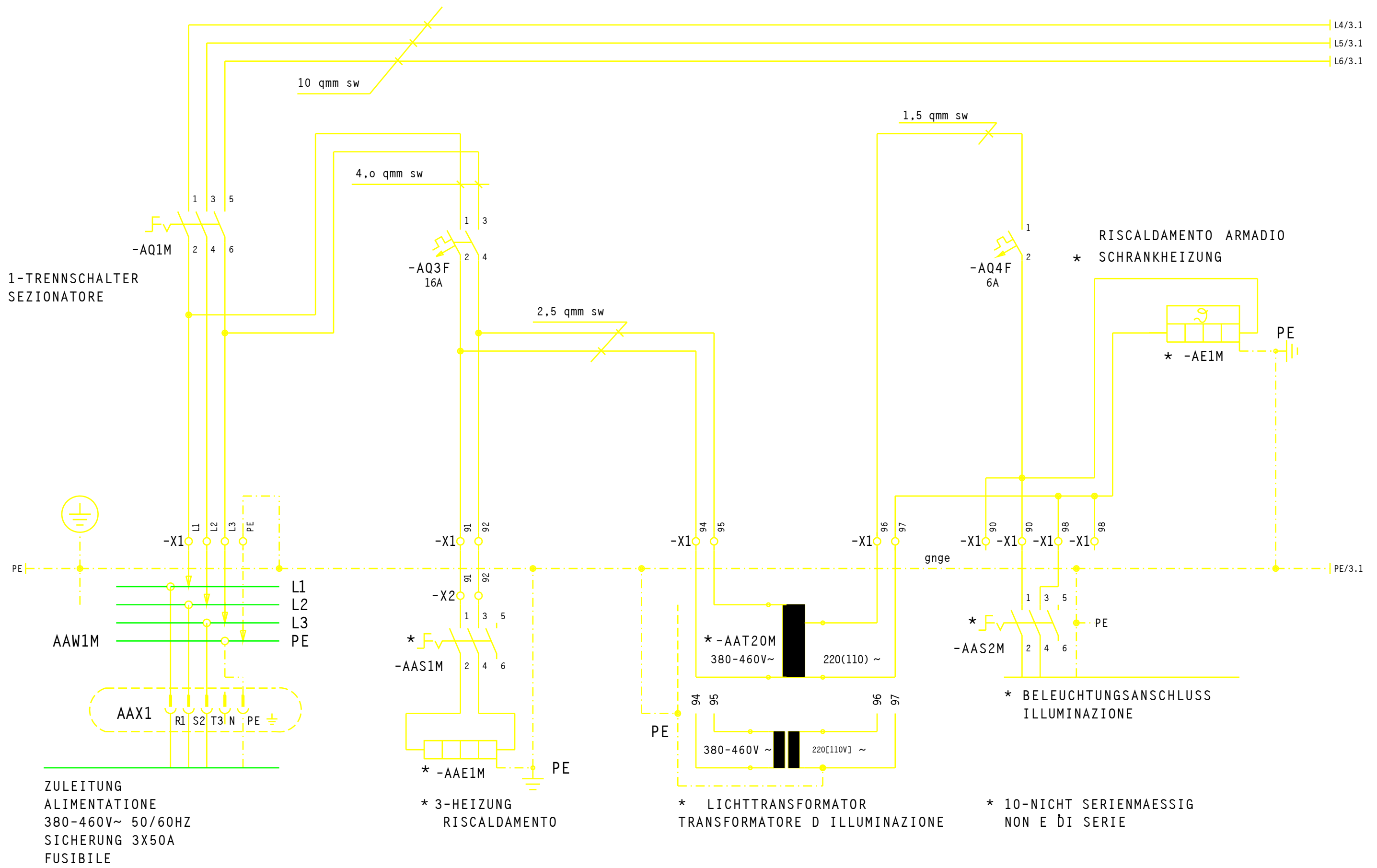

3			Gez.	31.08.09	HUBER		Maßstab	LIEBHERR-WERK BIBERACH GmbH	11-EINSPEISUNG ALIMENTAZIONE	TYPE	35K ITALIEN	=	S1
2			Bearb.				:			Zeich-Nr.	4005-21498	+	
1	Änderung	Datum	Name	Datum	Name			Copyright (c)				Blatt	2+
												Ident Nr.	611168501

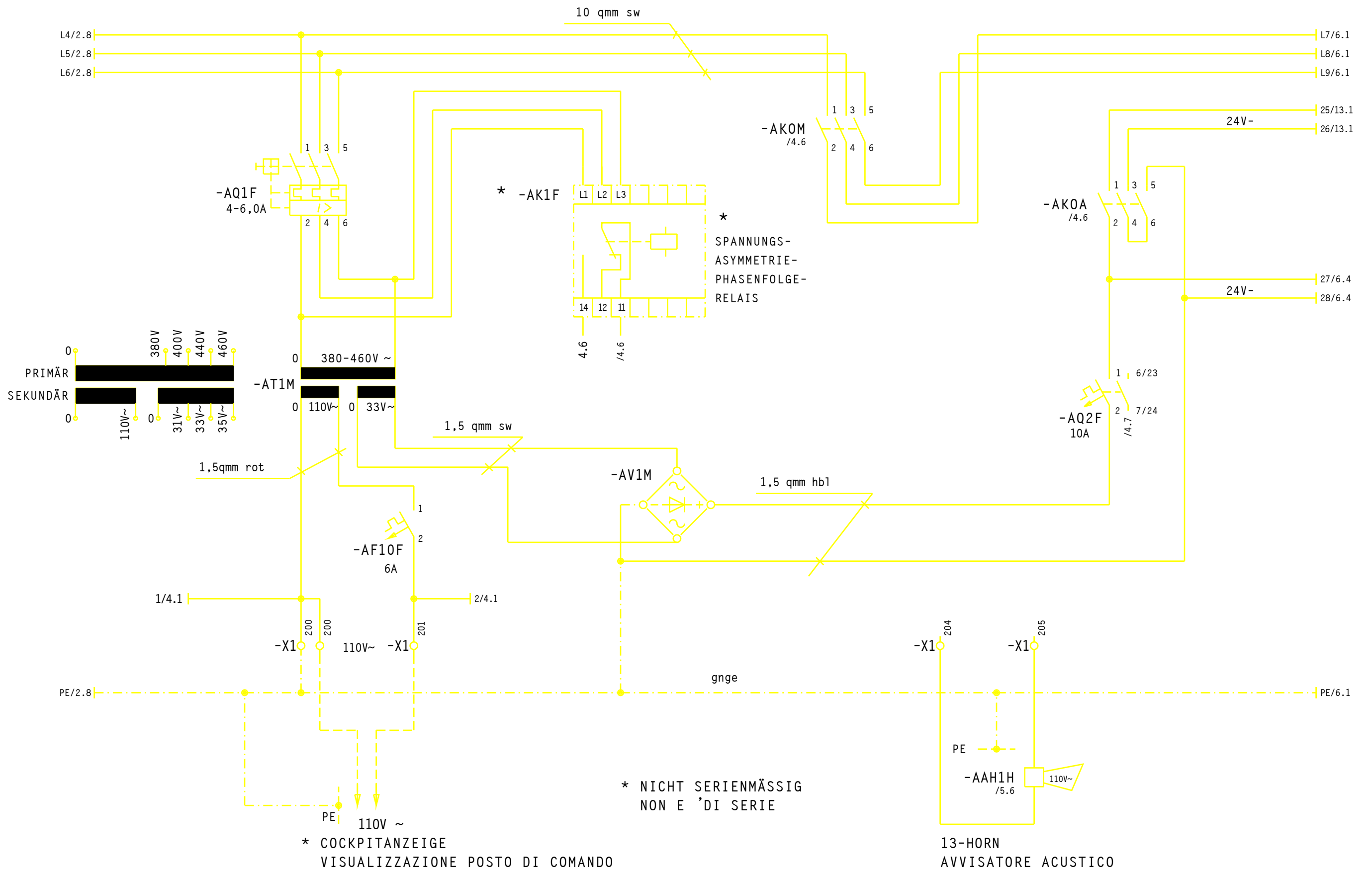

3			Gez.	31.08.09	HUBER		Maßstab	LIEBHERR-WERK BIBERACH GmbH	11-EINSPEISUNG ALIMENTAZIONE	TYPE	35K ITALIEN	=	S1
2			Bearb.				:			Zeich-Nr.	4005-21498	+	Blatt 3+
1	Änderung	Datum	Name	Datum	Name			Copyright (c)					Ident Nr. 611168501

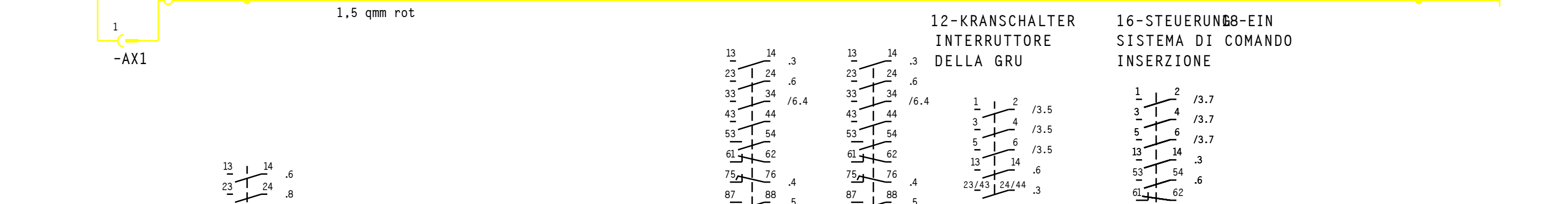
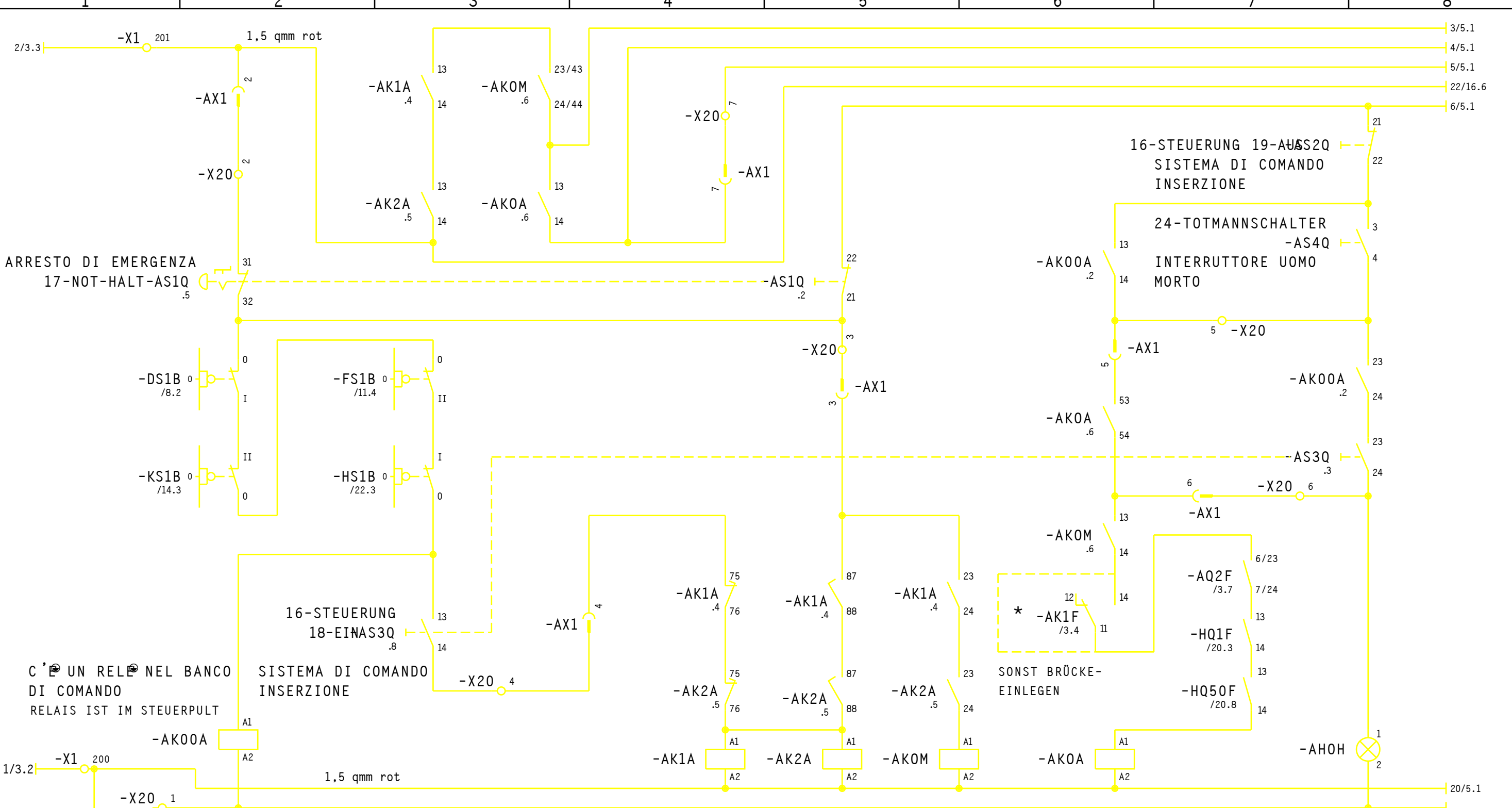

3			Gez.	31.08.09	HUBER		Maßstab	LIEBHERR-WERK BIBERACH GmbH	16-STEUERUNG SYSTEMA DI COMANDO	TYPE	35K ITALIEN	=	S1
2			Bearb.				:			Zeich-Nr.	4005-21498	+	
1	Änderung	Datum	Name	Datum	Name			Copyright (c)				Blatt	4+
												Ident Nr.	611168501

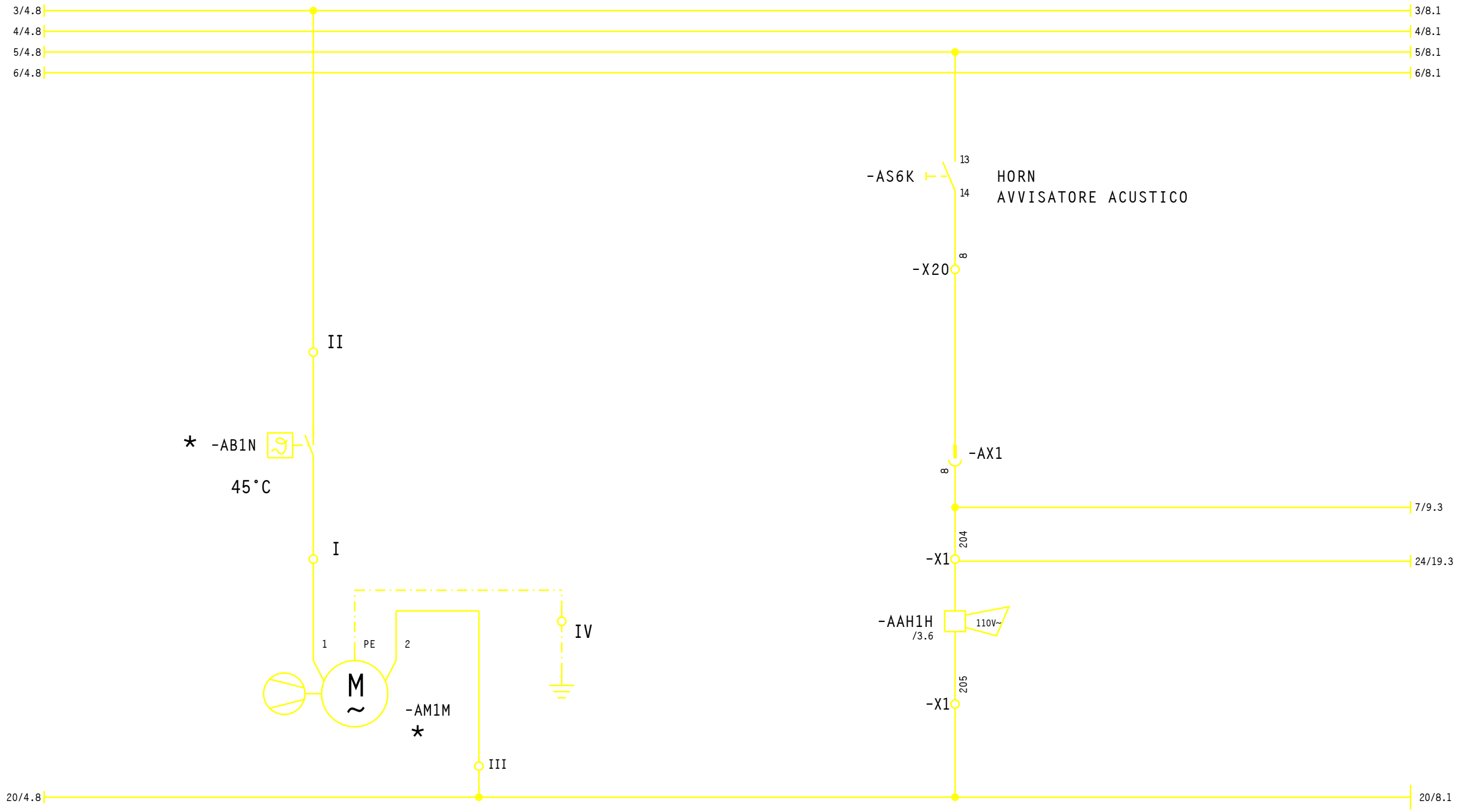

* VENTILATOR
VENTILATORE

* NICHT SERIENMÄBIG
NON E 'DI SERIE

HORN
AVVISATORE ACUSTICO

3			Gez.	31.08.09	HUBER		Maßstab	LIEBHERR-WERK	13-HORN	TYPE	35K ITALIEN	=	S1
2			Bearb.				:	BIBERACH GmbH	AVVISATORE ACUSTICO	Zeich-Nr.	4005-21498	+	
1	Änderung	Datum	Name	Datum	Name			Copyright (c)				Blatt	5+
												Ident Nr.	611168501

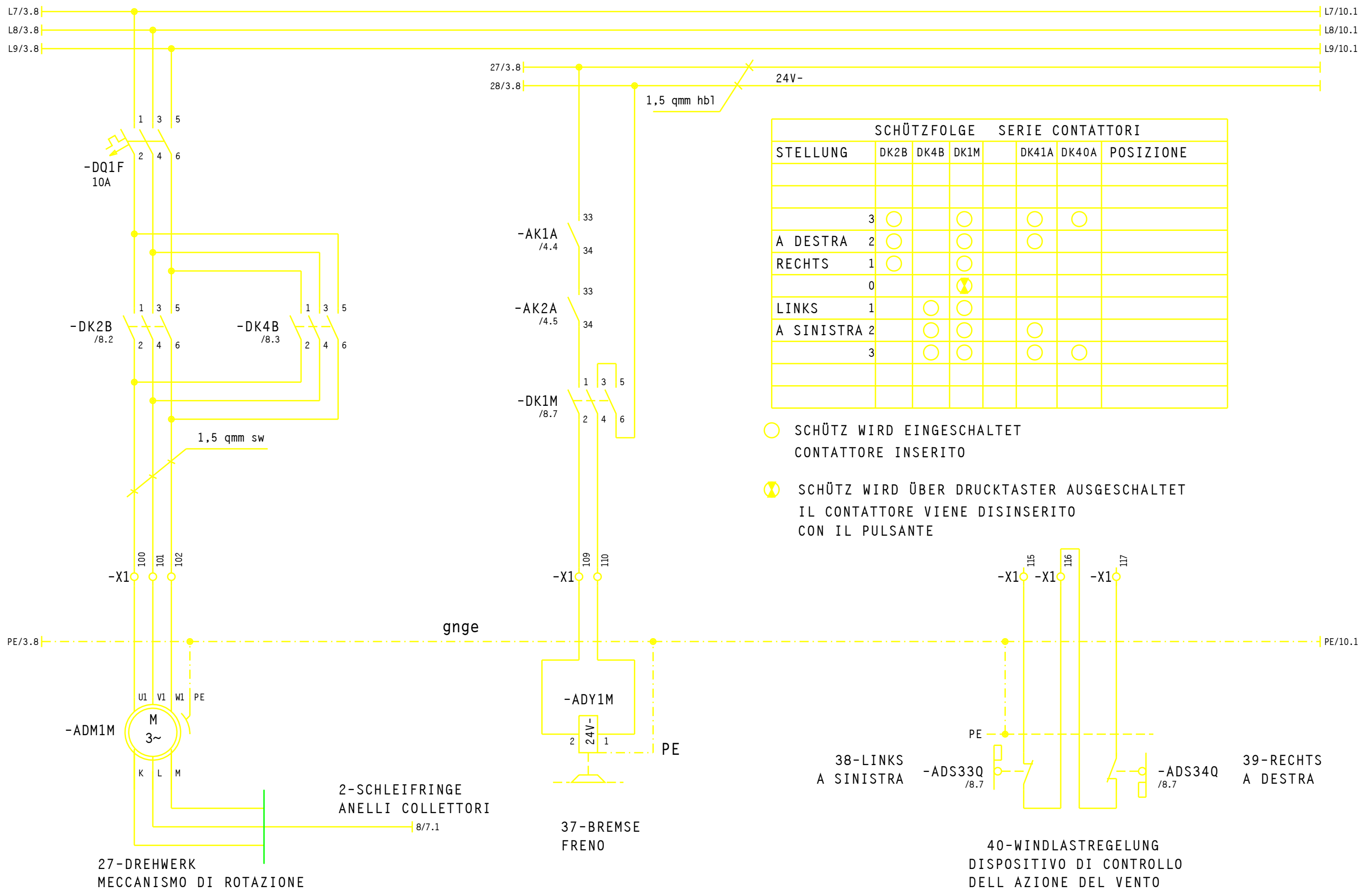

STELLUNG	SCHÜTZFOLGE					POSIZIONE
	DK2B	DK4B	DK1M	DK41A	DK40A	
	3					
A DESTRA	2					
RECHTS	1					
	0					
LINKS	1					
A SINISTRA	2					
	3					

- SCHÜTZ WIRD EINGESCHALTET
CONTATTORE INSERITO
- ⊗ SCHÜTZ WIRD ÜBER DRUCKTASTER AUSGESCHALTET
IL CONTATTORE VIENE DISINSERITO
CON IL PULSANTE

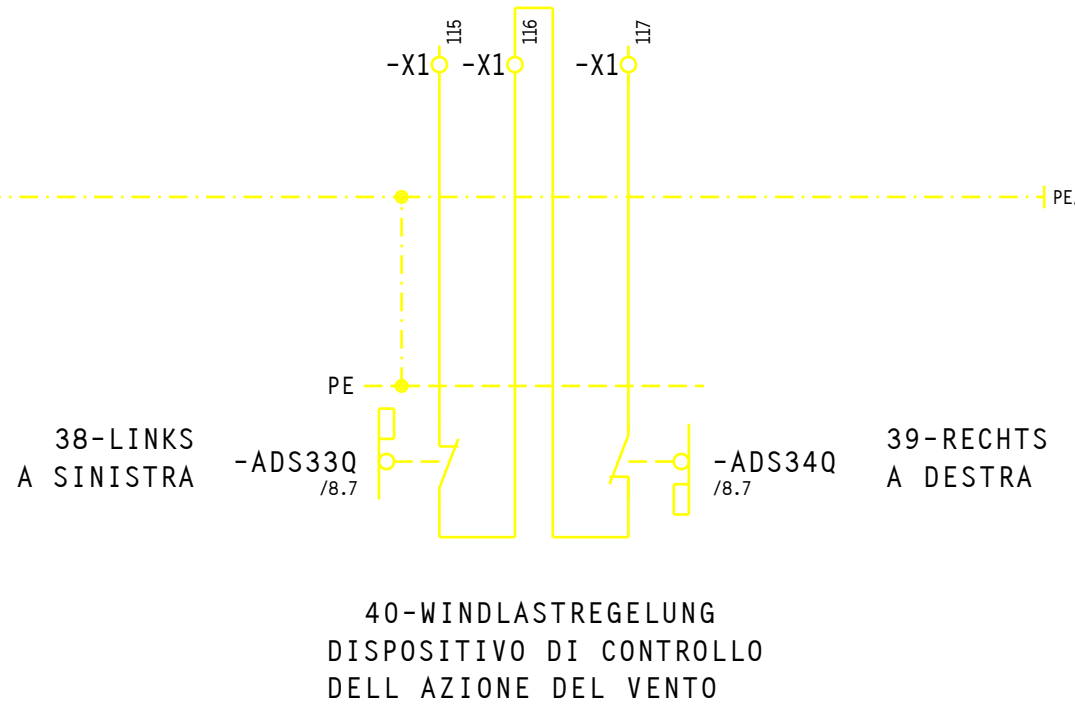

3			Gez.	31.08.09	HUBER		Maßstab	LIEBHERR-WERK BIBERACH GmbH	27-DREHWERK MECANISMO DI ROTAZIONE	TYPE	35K ITALIEN	=	S1
2			Bearb.				:			Zeich-Nr.	4005-21498	+	
1	Änderung	Datum	Name	Datum	Name			Copyright (c)				Blatt	6+
												Ident Nr.	611168501

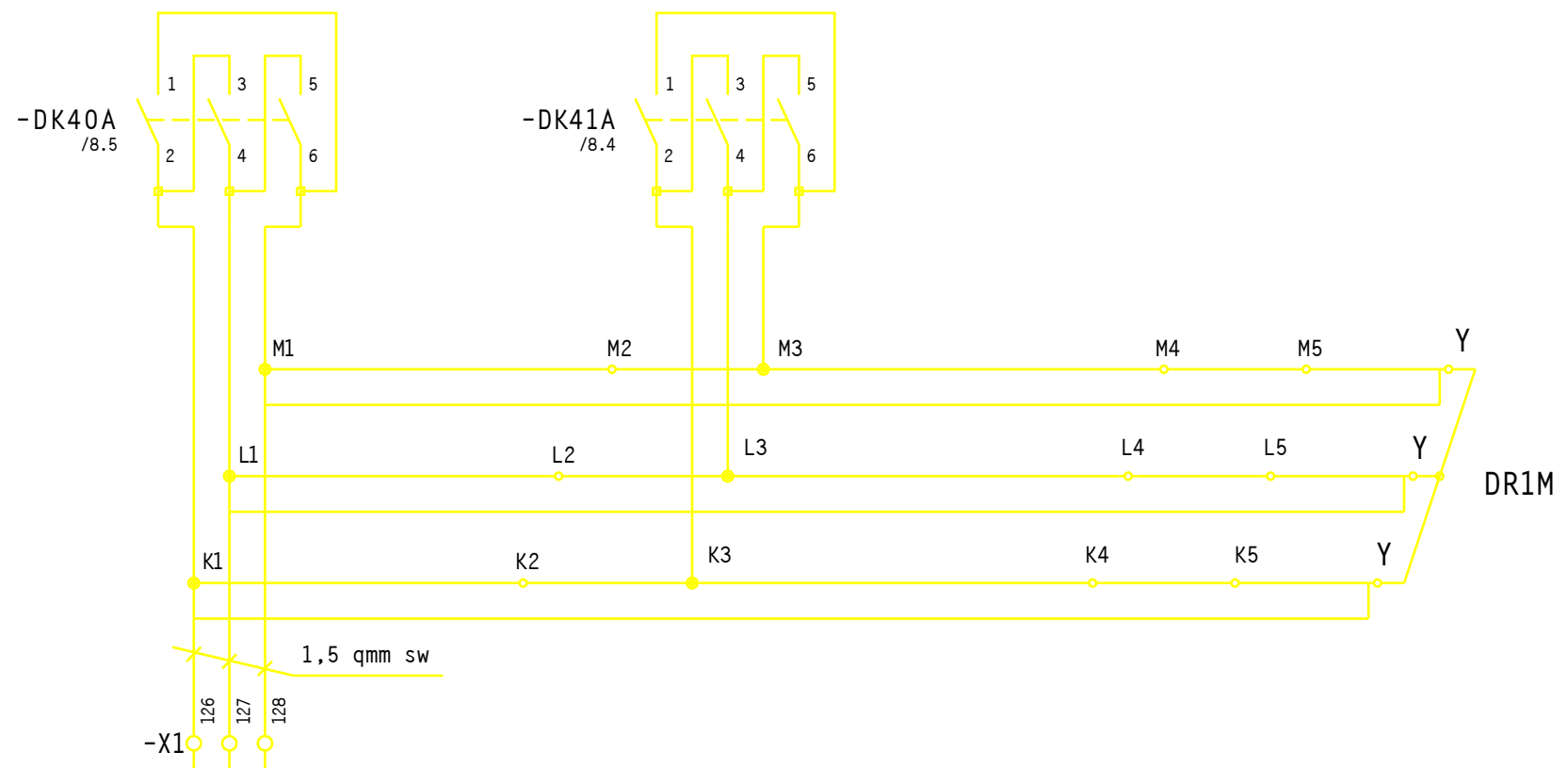

2-SCHLEIFRINGE
ANELLI COLLETTORI
8/6.3

WIDERSTANDSWERTE pro. PHASE

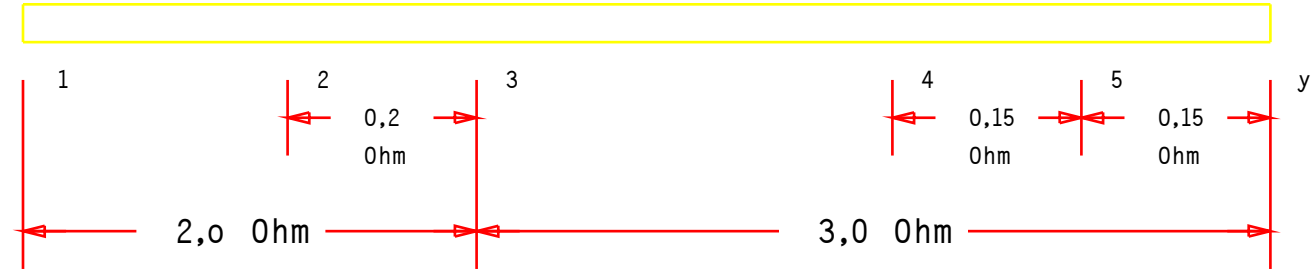

3			Gez.	31.08.09	HUBER		Maßstab	LIEBHERR-WERK	27-DREHWERK	TYPE	35K ITALIEN	=	S1
2			Bearb.				:	BIBERACH GmbH	MECCANISMO DI ROTAZIONE	Zeich-Nr.	4005-21498	+	
1	Änderung	Datum	Name	Datum	Name		Copyright (c)					Blatt	7+
												Ident Nr.	611168501

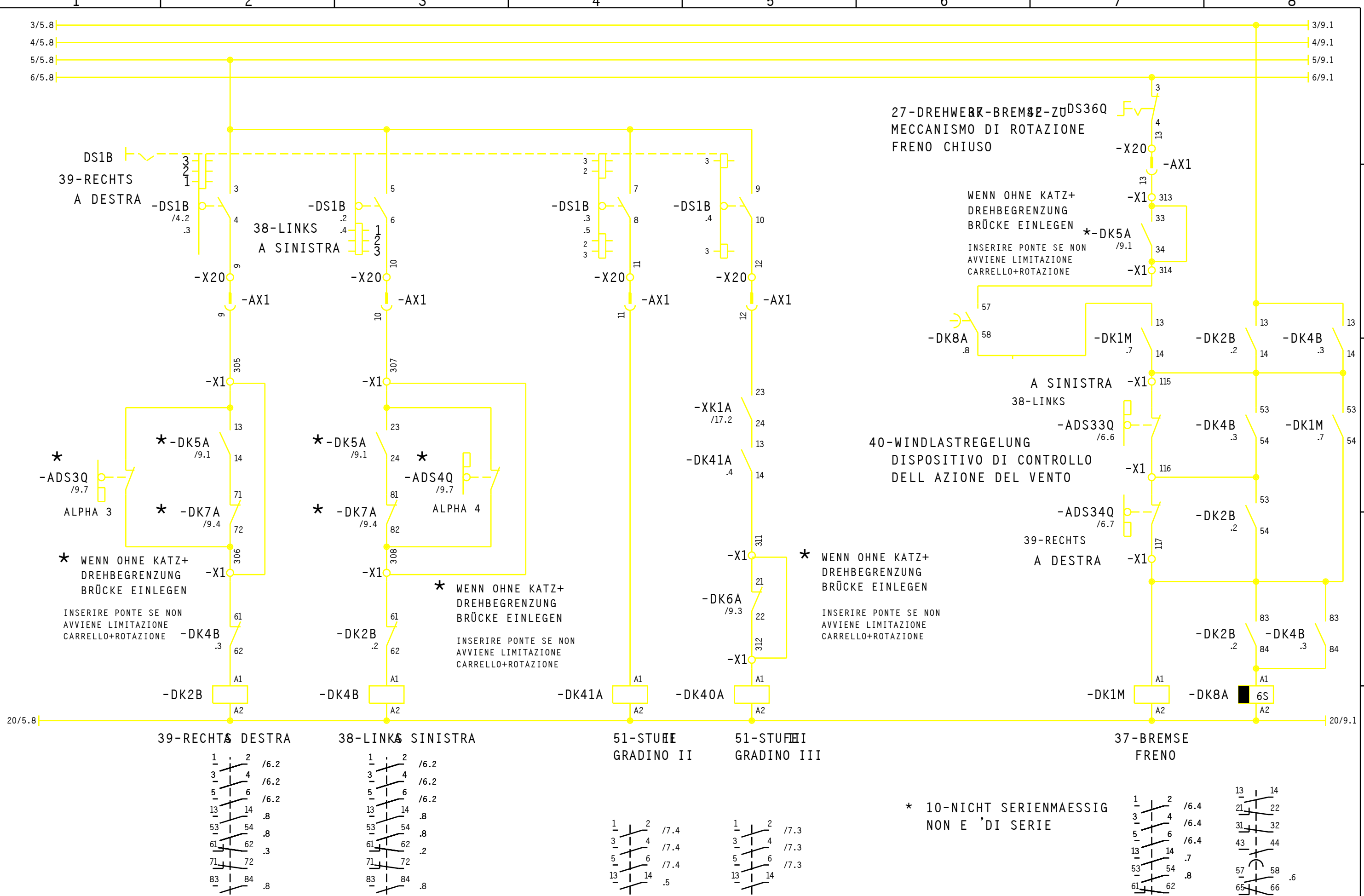

27-DREHWERK-BREMSE-ZU DS36Q
 MECCANISMO DI ROTAZIONE
 FRENO CHIUSO

WENN OHNE KATZ+
 DREHBEGRENZUNG
 BRÜCKE EINLEGEN
 * -DK5A /9.1
 INSERIRE PONTE SE NON
 AVVIENE LIMITAZIONE
 CARRELLO+ROTAZIONE

40-WINDLASTREGELUNG
 DISPOSITIVO DI CONTROLLO
 DELL AZIONE DEL VENTO

* WENN OHNE KATZ+
 DREHBEGRENZUNG
 BRÜCKE EINLEGEN
 INSERIRE PONTE SE NON
 AVVIENE LIMITAZIONE
 CARRELLO+ROTAZIONE

* WENN OHNE KATZ+
 DREHBEGRENZUNG
 BRÜCKE EINLEGEN
 INSERIRE PONTE SE NON
 AVVIENE LIMITAZIONE
 CARRELLO+ROTAZIONE

* 10-NICHT SERIENMAESSIG
 NON E 'DI SERIE

3			Gez.	31.08.09	HUBER		Maßstab	LIEBHERR-WERK	27-DREHWERK	TYPE	35K ITALIEN	=	S1
2			Bearb.				:	BIBERACH GmbH	MECCANISMO DI ROTAZIONE	Zeich-Nr.	4005-21498	+	
1	Änderung	Datum	Name	Datum	Name			Copyright (c)				Blatt	8+
												Ident Nr.	611168501

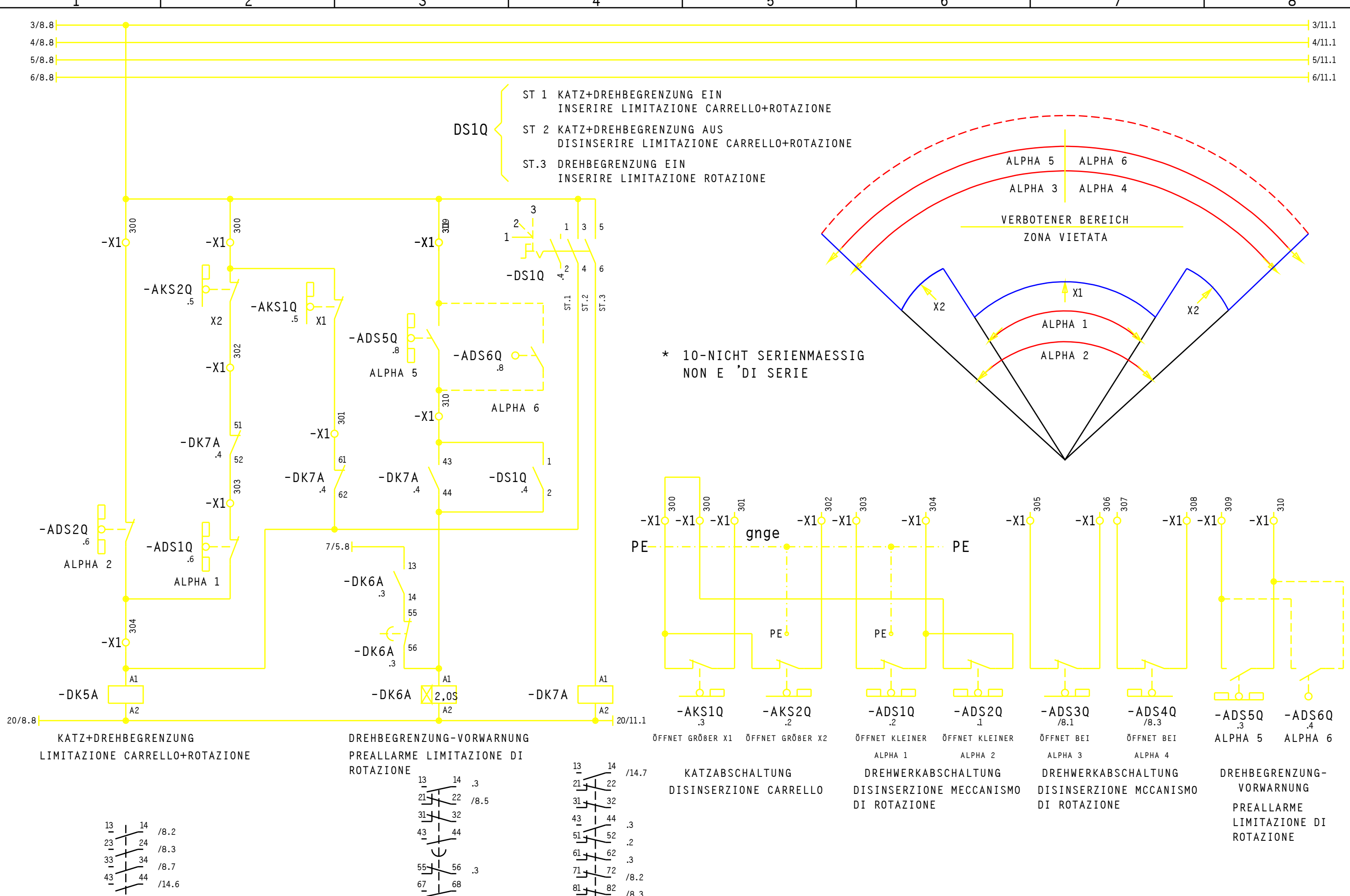

3				Gez.	31.08.09	HUBER		Maßstab	LIEBHERR-WERK	KATZ+DREHBEGRENZUNG * LIMITAZIONE CARRELLO+ROTAZIONE	TYPE	35K ITALIEN	=	S1	
2				Bearb.			:	BIBERACH GmbH	Zeich-Nr.		4005-21498	+		Blatt	9+
1	Änderung	Datum	Name	Datum	Name			Copyright (c)						Ident Nr.	611168501

13	14	/8.2
23	24	/8.3
33	34	/8.7
43	44	/14.6

13	14	.3
21	22	/8.5
31	32	
43	44	.3
51	52	.2
61	62	.3
71	72	/8.2
81	82	/8.3

13	14	/14.7
21	22	
31	32	
43	44	.3
51	52	.2
61	62	.3
71	72	/8.2
81	82	/8.3

13	14	.3
21	22	/8.5
31	32	
43	44	.3
51	52	.2
61	62	.3
71	72	/8.2
81	82	/8.3

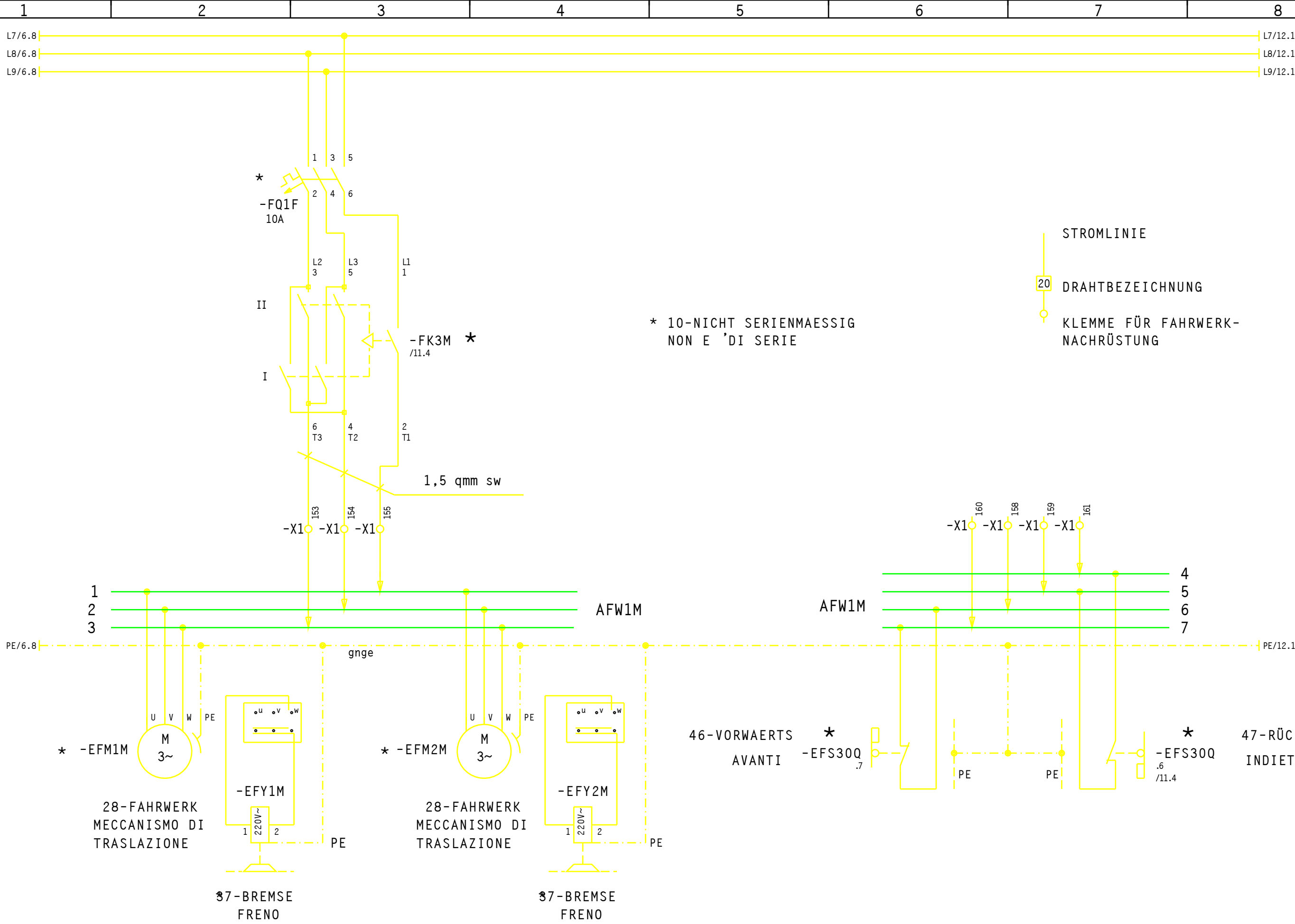

3			Gez.	31.08.09	HUBER		Maßstab	LIEBHERR-WERK BIBERACH GmbH	28-FAHRWERK *	TYPE	35K ITALIEN	=	S1
2			Bearb.				:		MECCANISMO DI TRASLAZIONE	Zeich-Nr.	4005-21498	+	
1	Änderung	Datum	Name	Datum	Name			Copyright (c)				Blatt	10+
												Ident Nr.	611168501

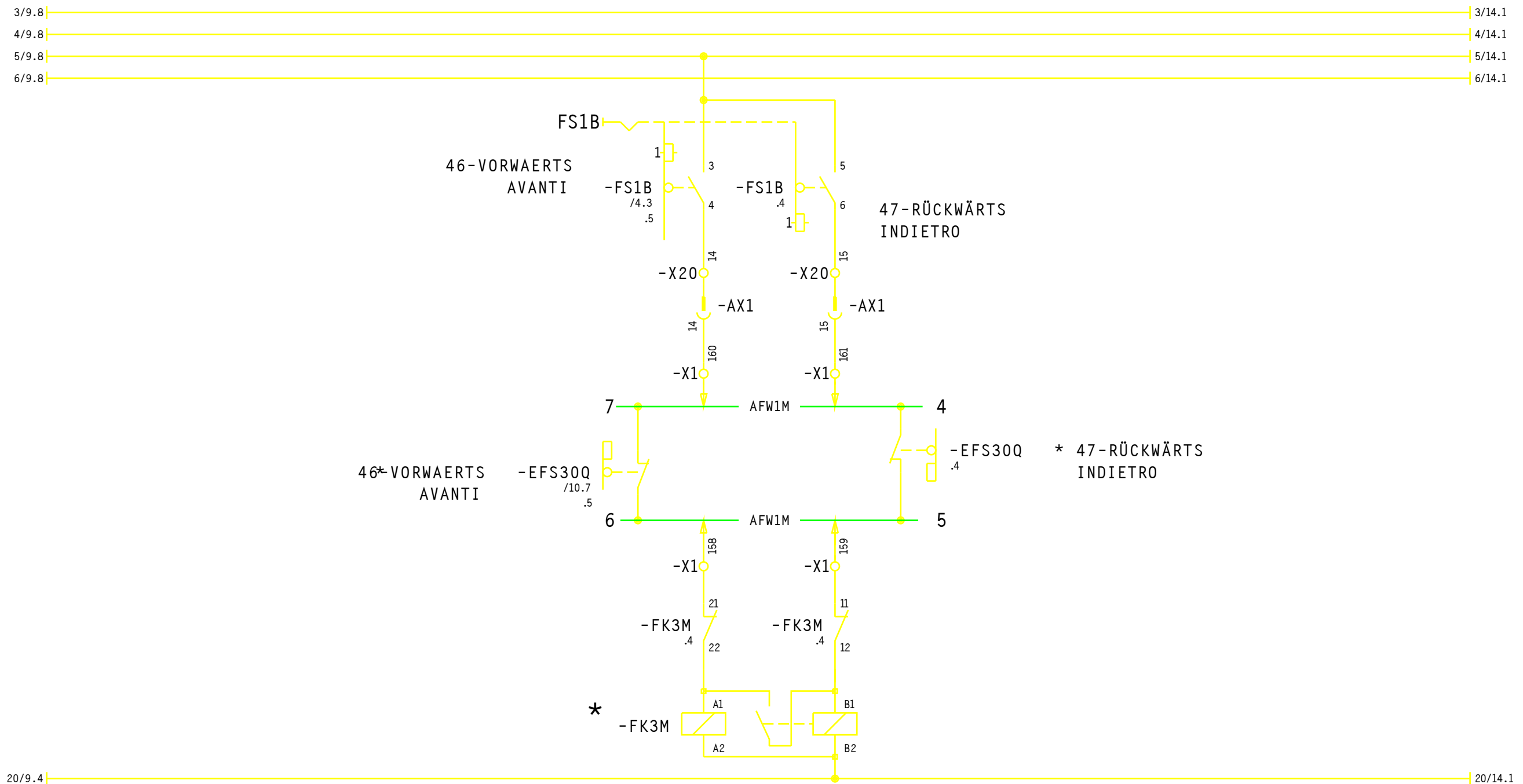

46-VORWAERTS AVANTI 47-RÜCKWÄRTS INDIETRO

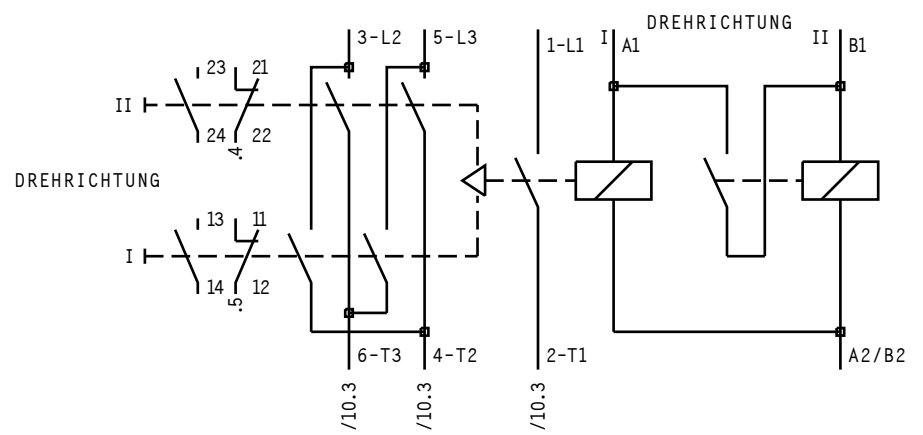

* 10-NICHT SERIENMAESSIG
NON E 'DI SERIE

3			Gez.	31.08.09	HUBER		Maßstab	LIEBHERR-WERK	28-FAHRWERK * MECCANISMO DI TRASLAZIONE	TYPE	35K ITALIEN	=	S1	
2			Bearb.			:	BIBERACH GmbH	Zeich-Nr.		4005-21498	Blatt	11+	+	
1	Änderung	Datum	Name	Datum	Name		Copyright (c)				Ident Nr.	611168501		

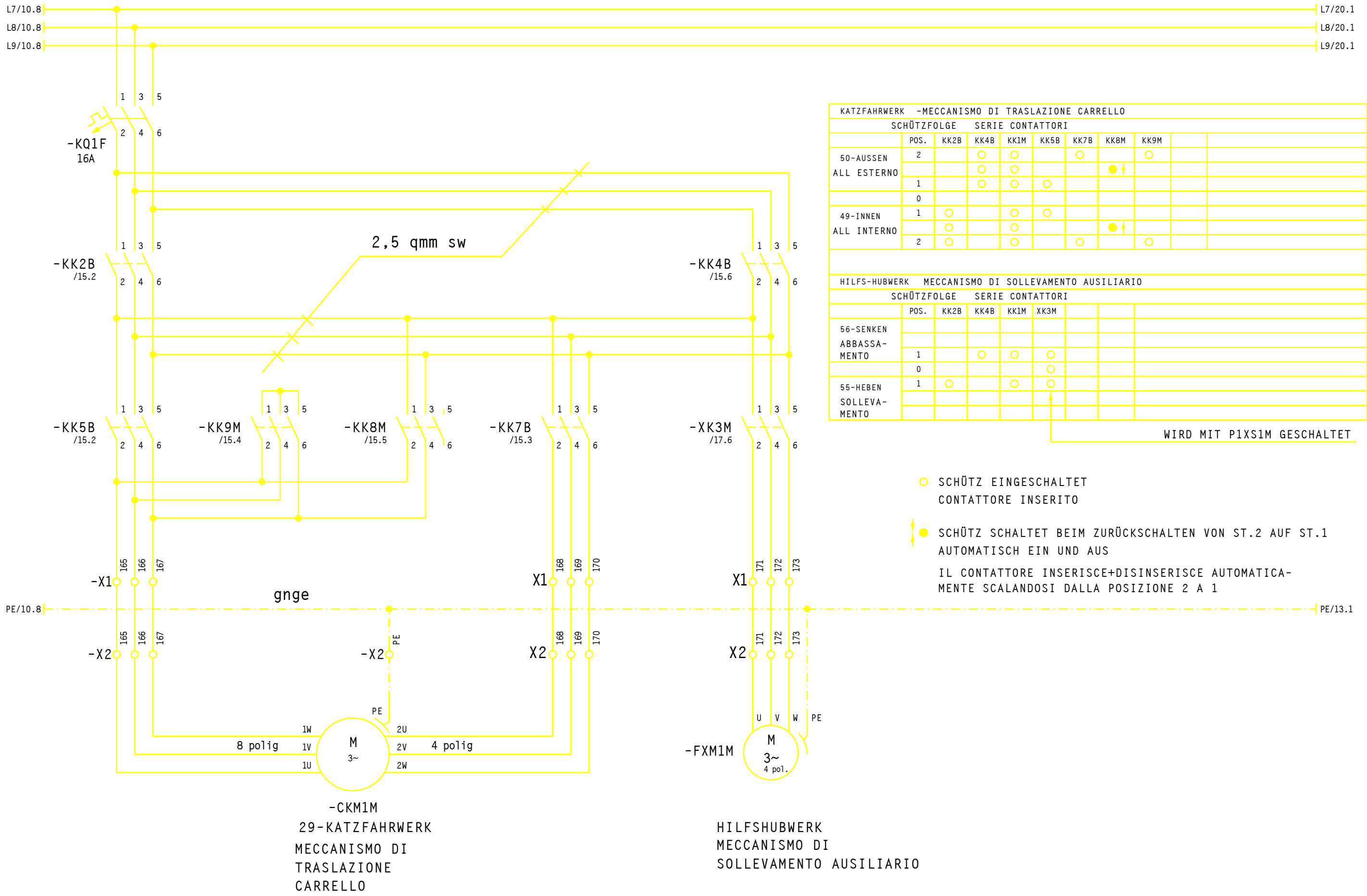

KATZFAHRWERK -MECCANISMO DI TRASLAZIONE CARRELLO								
SCHÜTZFOLGE		SERIE CONTATTORI						
	POS.	KK2B	KK4B	KK1M	KK5B	KK7B	KK8M	KK9M
50-AUSSEN ALL ESTERNO	2	○	○	○		○		○
	1		○	○	○		●	
	0							
49-INNEN ALL INTERNO	1	○		○	○			
	0	○		○			●	
	2	○		○		○		○

HILFS-HUBWERK MECCANISMO DI SOLLEVAMENTO AUSILIARIO					
SCHÜTZFOLGE		SERIE CONTATTORI			
	POS.	KK2B	KK4B	KK1M	XK3M
56-SENKEN ABBASSA- MENTO	1		○	○	○
	0				○
	1	○		○	○

○ SCHÜTZ EINGESCHALTET
CONTATTORE INSERITO

● SCHÜTZ SCHALTET BEIM ZURÜCKSCHALTEN VON ST.2 AUF ST.1
AUTOMATISCH EIN UND AUS

IL CONTATTORE INSERISCE+DISINSERISCE AUTOMATICAMENTE
SCALANDOSI DALLA POSIZIONE 2 A 1

WIRD MIT PIXSIM GESCHALTET

3			Gez.	31.08.09	HUBER	Maßstab	LIEBHERR-WERK	KATZFAHRWERK-MECCANISMO DI	TYPE	35K ITALIEN	=	S1
2			Bearb.			:	BIBERACH GmbH	TRASLAZIONE CARRELLO	Zeich-Nr.	4005-21498	+	
1	Änderung	Datum	Name	Datum	Name		Copyright (c)				Blatt	12+
											Ident Nr.	611168501

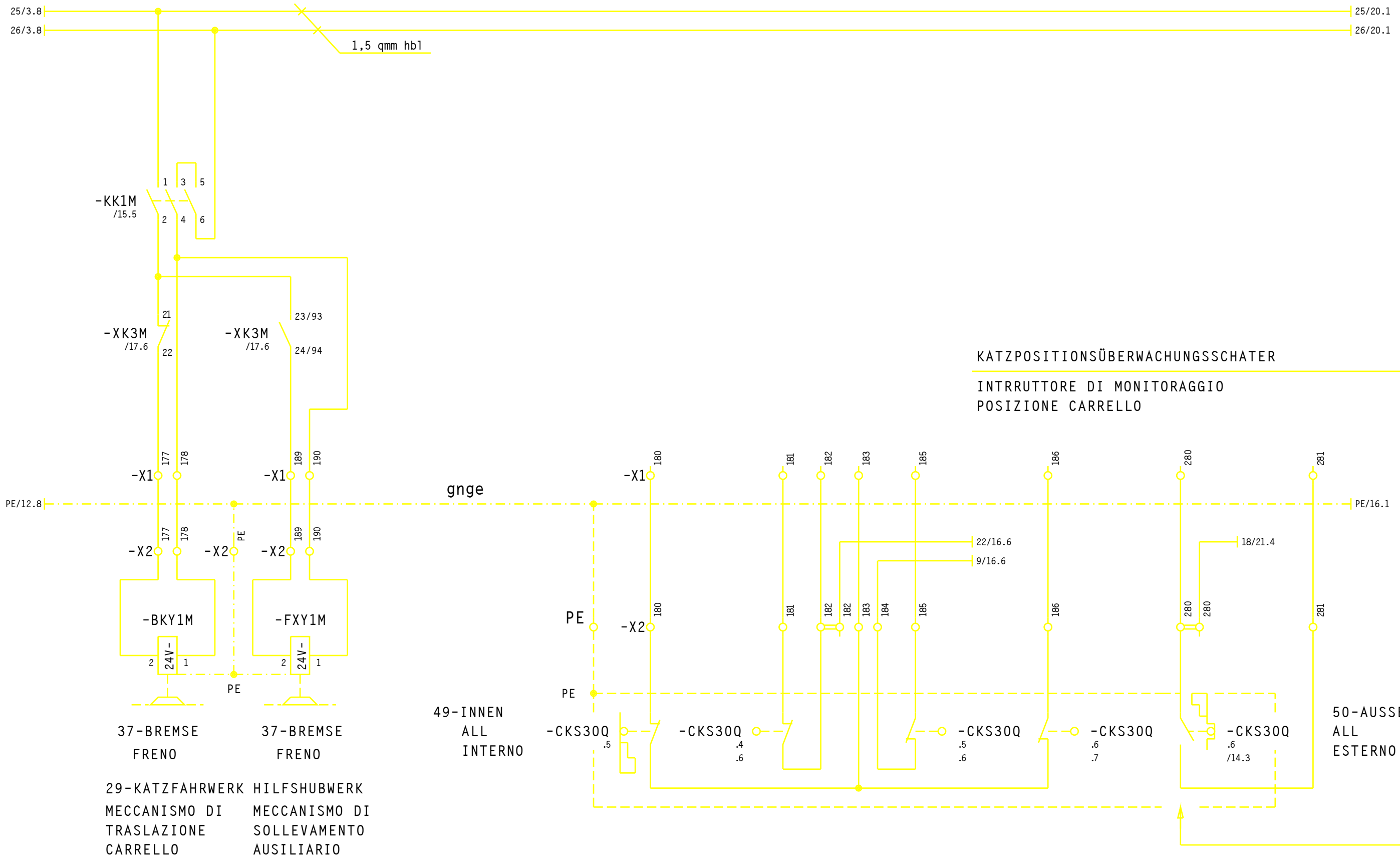

3			Gez.	31.08.09	HUBER		Maßstab	LIEBHERR-WERK BIBERACH GmbH	KATZFAHRWERK-HILFSHUBWERK	TYPE	35K ITALIEN	=	S1
2			Bearb.				:		MECCANISMO DI TRASLAZIONE CARR	Zeich-Nr.	4005-21498	+	
1	Änderung	Datum	Name	Datum	Name		Copyright (c)					Blatt	13+
												Ident Nr.	611168501

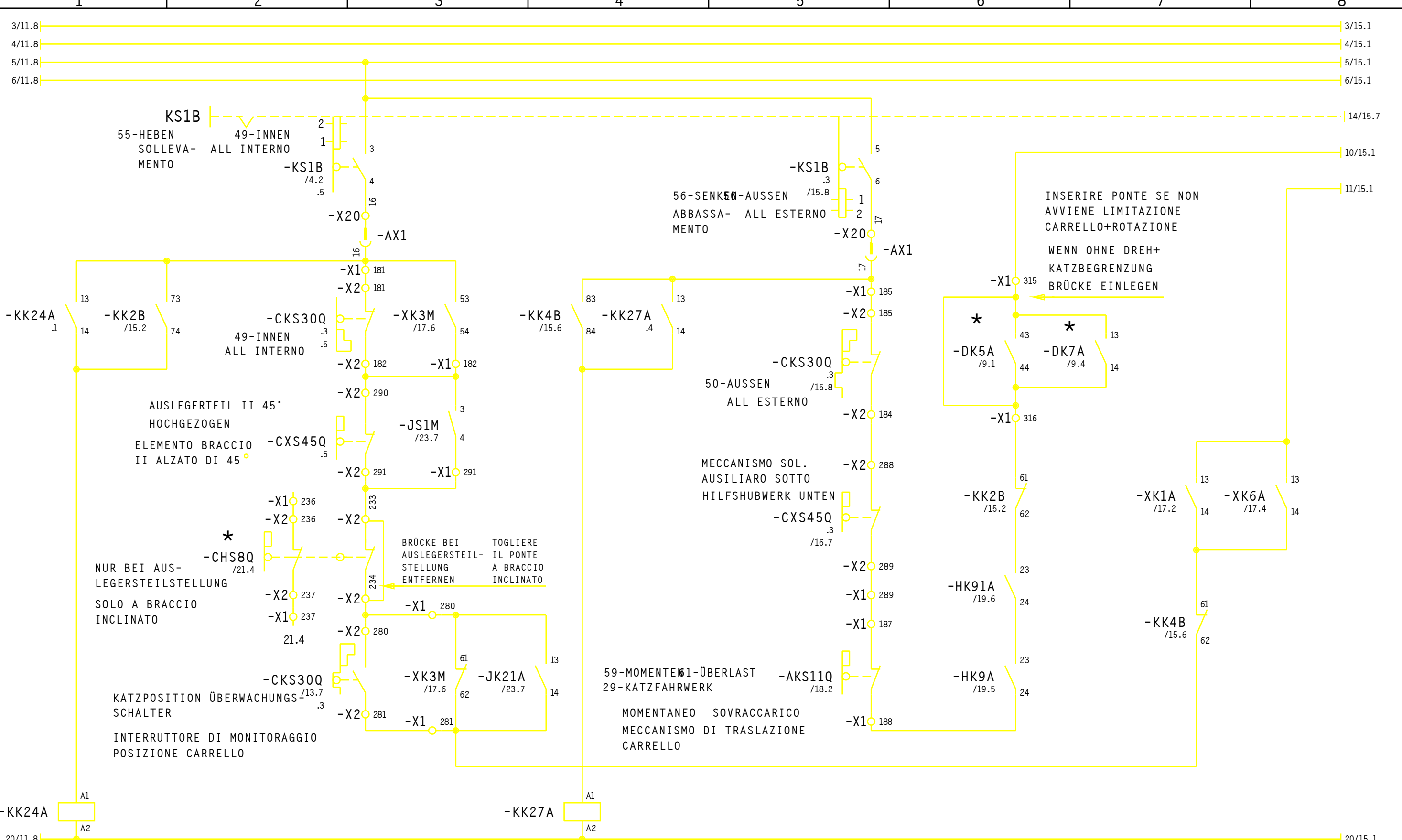

* 10-NICHT SERIENMAESSIG
NON E 'DI SERIE

3			Gez.	31.08.09	HUBER	Maßstab	LIEBHERR-WERK BIBERACH GmbH	KATZFAHRWERK-HILFSHUBWERK	TYPE	35K ITALIEN	=	S1
2			Bearb.			:		MECCANISMO DI TRASLAZIONE SARR	Zeich-Nr.	4005-21498	+	
1	Änderung	Datum	Name	Datum	Name		Copyright (c)				Blatt	14+
											Ident Nr.	611168501

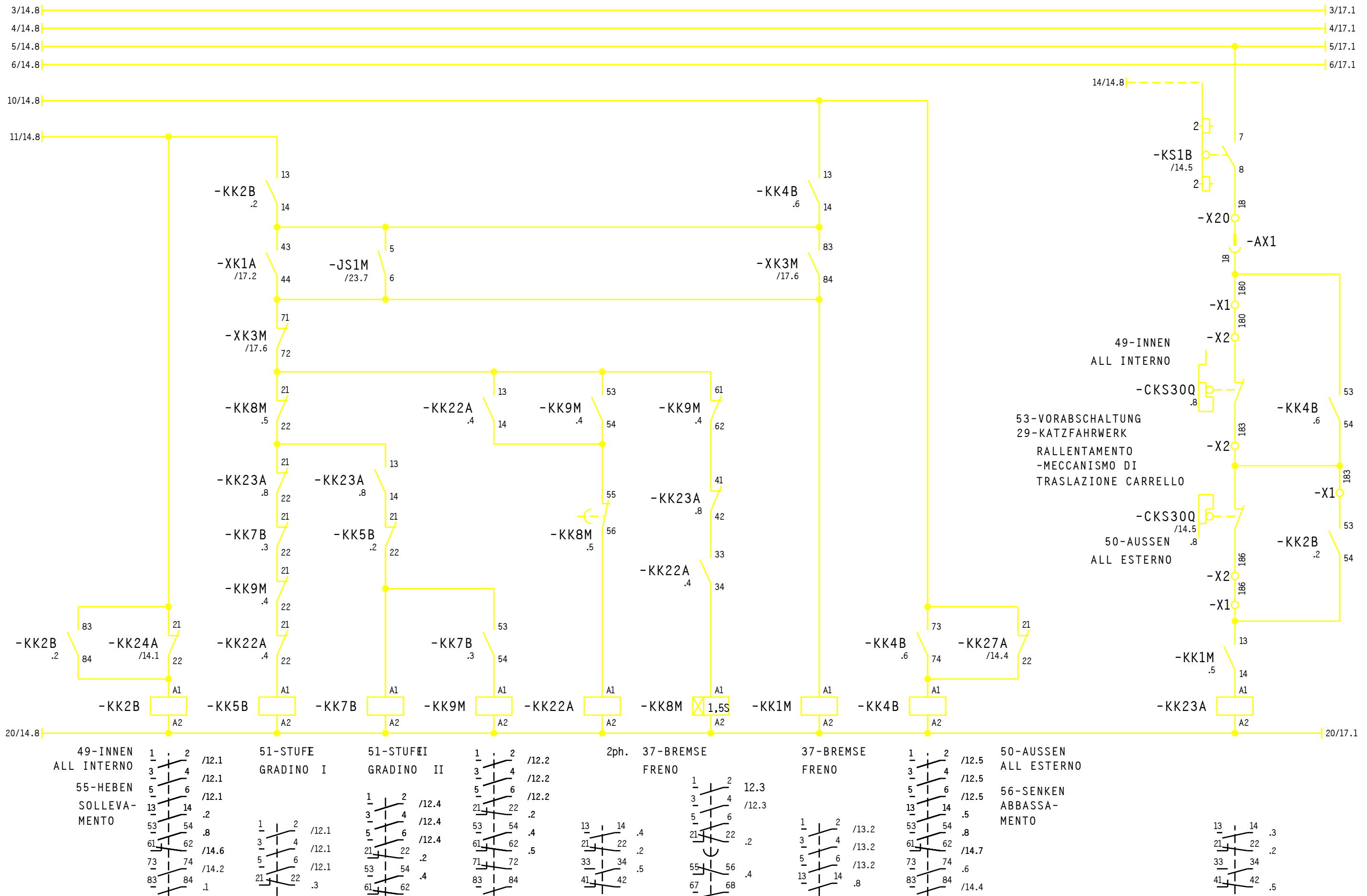

3			Gez.	31.08.09	HUBER		Maßstab	LIEBHERR-WERK BIBERACH GmbH	KATZFAHRWERK-HILFSHUBWERK	TYPE	35K ITALIEN	=	S1
2			Bearb.				:		MECCANISMO DI TRASLAZIONE CARR	Zeich-Nr.	4005-21498	+	
1	Änderung	Datum	Name	Datum	Name			Copyright (c)				Blatt	15+
												Ident Nr.	611168501

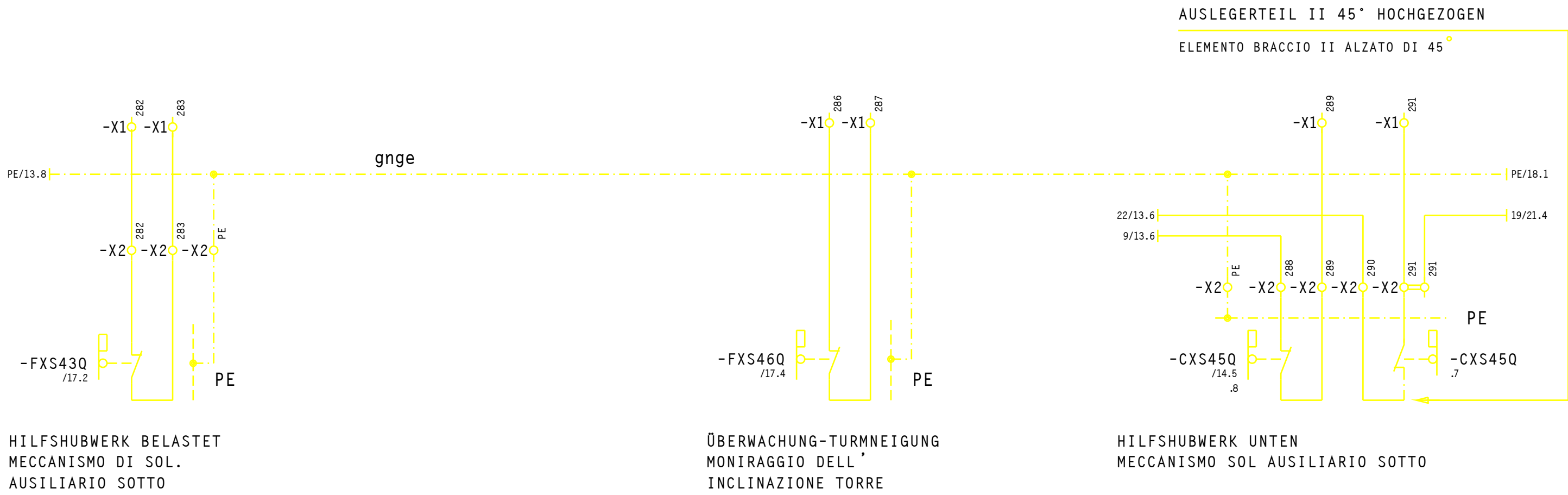

3			Gez.	31.08.09	HUBER		Maßstab	LIEBHERR-WERK	HILFSHUBWERK	TYPE	35K ITALIEN	=	S1
2			Bearb.				:	BIBERACH GmbH	MECCANISMO DI SOLLEVAMENTO AUS	Zeich-Nr.	4005-21498	+	
1	Änderung	Datum	Name	Datum	Name			Copyright (c)				Blatt	16+
												Ident Nr.	611168501

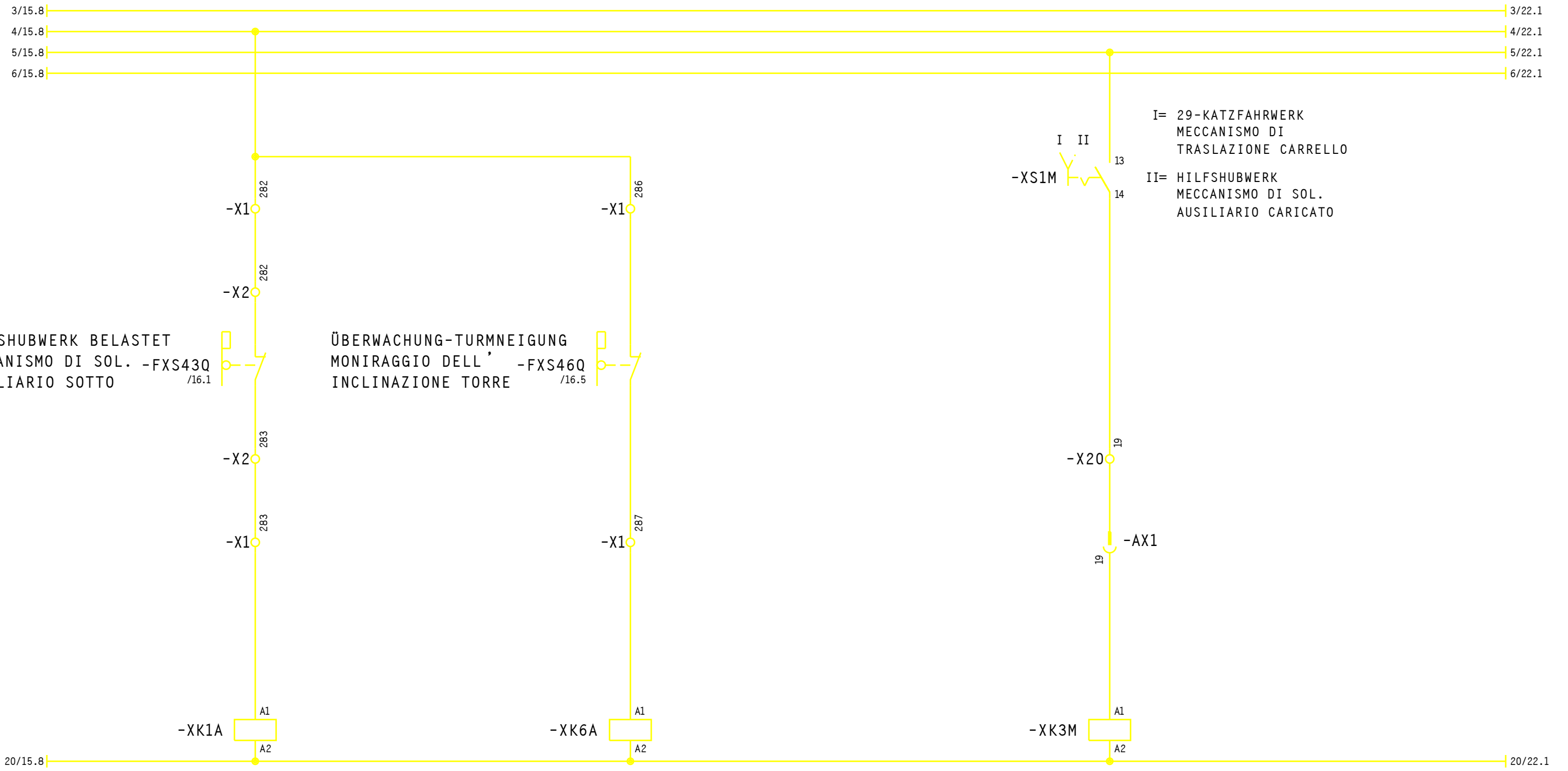

I= 29-KATZFAHRWERK
 MECCANISMO DI
 TRASLAZIONE CARRELLO
 II= HILFSHUBWERK
 MECCANISMO DI SOL.
 AUSILIARIO CARICATO

HILFSHUBWERK BELASTET
 MECCANISMO DI SOL. -FXS43Q
 AUSILIARIO SOTTO /16.1

ÜBERWACHUNG-TURMNEIGUNG
 MONIRAGGIO DELL' INCLINAZIONE TORRE
 -FXS46Q /16.5

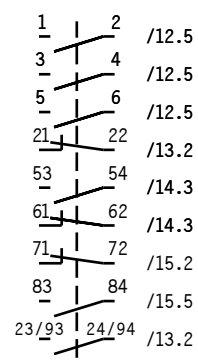
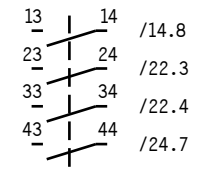
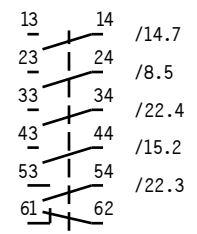

3			Gez.	31.08.09	HUBER		Maßstab	LIEBHERR-WERK	HILFSHUBWERK	TYPE	35K ITALIEN	=	S1
2			Bearb.				:	BIBERACH GmbH	MECCANISMO DI SOLLEVAMENTO AUS	Zeich-Nr.	4005-21498	+	
1	Änderung	Datum	Name	Datum	Name		Copyright (c)					Blatt	17+
												Ident Nr.	611168501

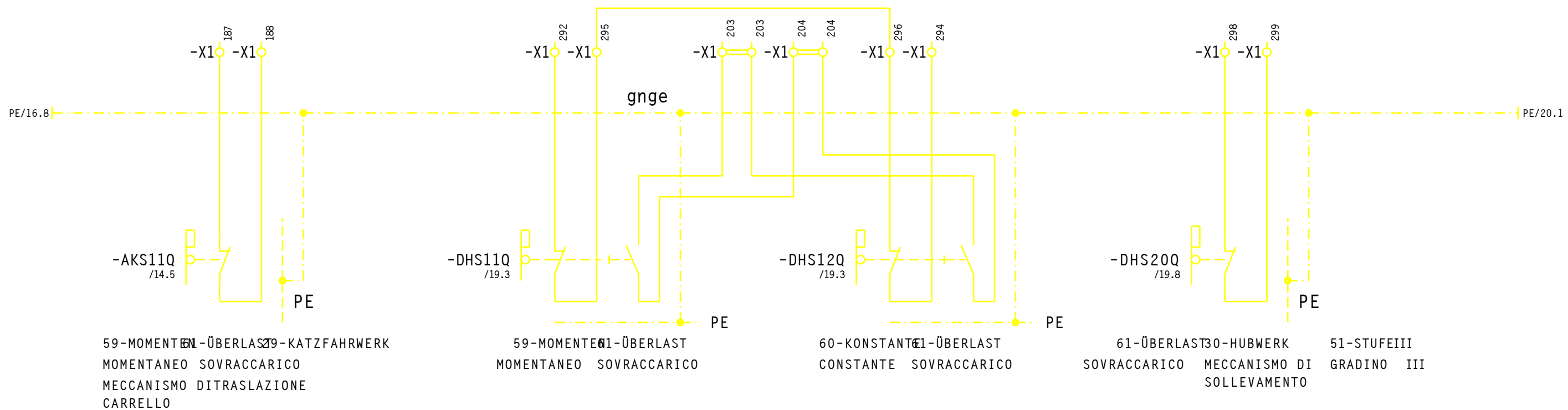

3			Gez.	31.08.09	HUBER		Maßstab	LIEBHERR-WERK	61-ÜBERLAST SOVRACCARICO	TYPE	35K ITALIEN	=	S1	
2			Bearb.			:	BIBERACH GmbH	Zeich-Nr.		4005-21498	+		Blatt	18+
1	Änderung	Datum	Name	Datum	Name		Copyright (c)				Ident Nr.	611168501		

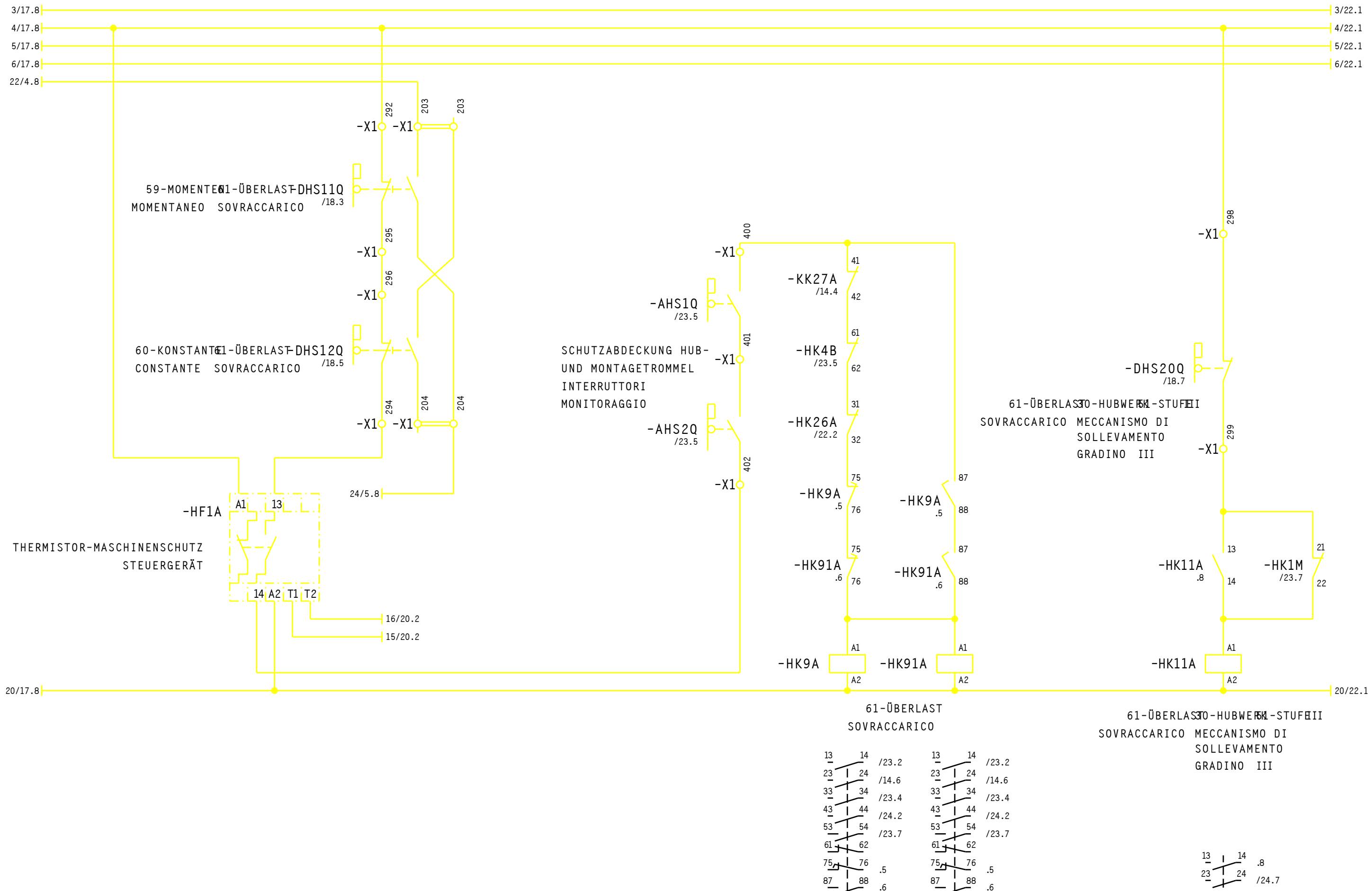

3			Gez.	31.08.09	HUBER		Maßstab	LIEBHERR-WERK BIBERACH GmbH	61-ÜBERLAST SOVRACCARICO	TYPE	35K ITALIEN	=	S1
2			Bearb.				:			Zeich-Nr.	4005-21498	+	
1	Änderung	Datum	Name	Datum	Name			Copyright (c)				Blatt	19+
												Ident Nr.	611168501

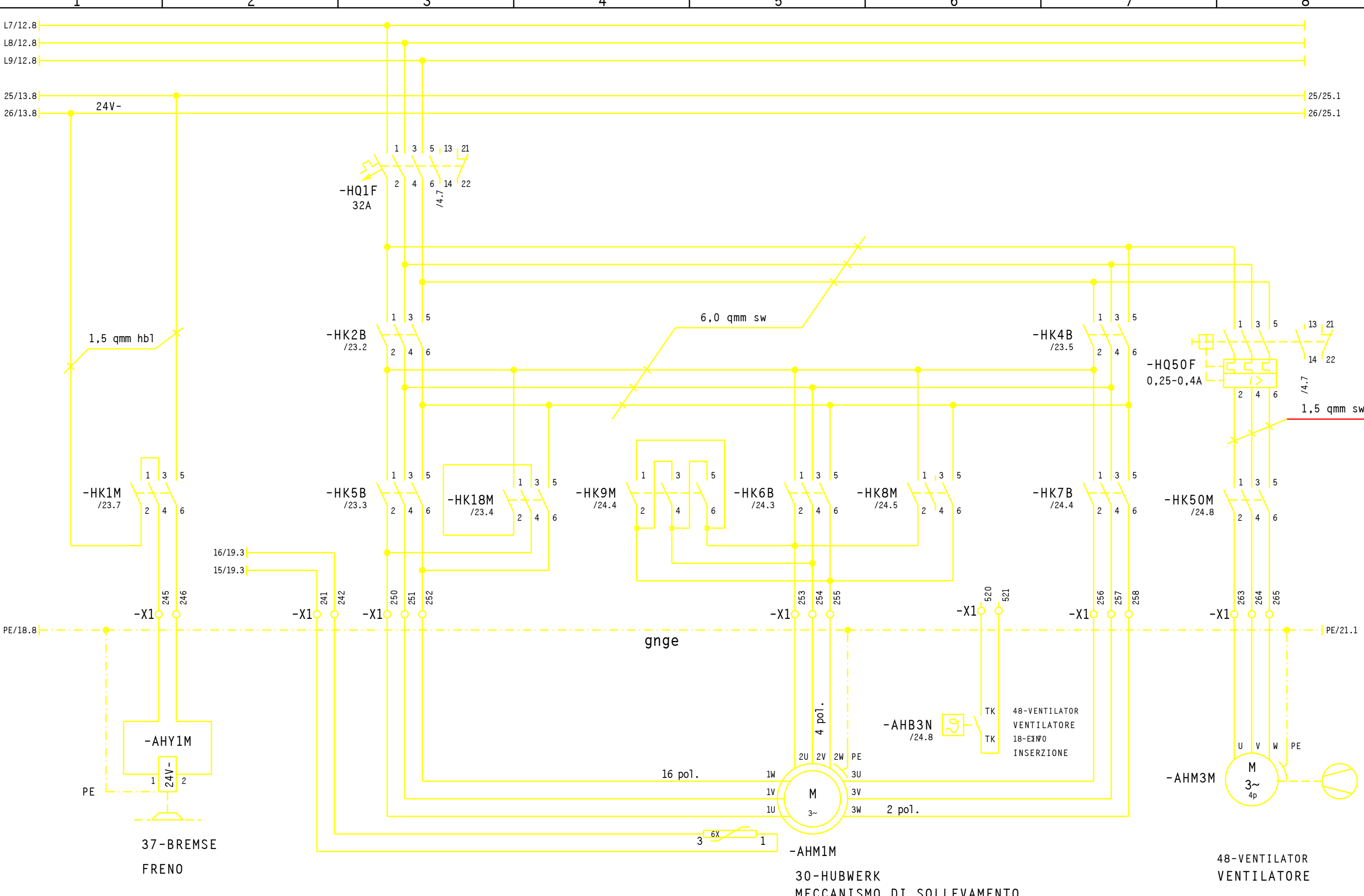

3			Gez.	31.08.09	HUBER		Maßstab	LIEBHERR-WERK	30-HUBWERK	TYPE	35K ITALIEN	=	S1
2			Bearb.				:	BIBERACH GmbH	MECCANISMO DI SOLLEVAMENTO	Zeich-Nr.	4005-21498	+	
1	Änderung	Datum	Name	Datum	Name			Copyright (c)				Blatt	20 +
												Ident Nr.	611168501

- CONTATTORE INSERITO
- ⊙ IL CONTATTORE INSERISCE CON RITARDO
- IL CONTATTORE INSERISE+DISINSERISCE AUTOMATICAMENTE SCALANDOSI DALLA POSIZIONE 3 A 2
- ⊗ IL CONTATTORE INSERISE+DISINSERISCE AUTOMATICAMENTE SCALANDOSI DALLA POSIZIONE 2 A 1

SCHÜTZFOLGE		SERIE CONTATTORI								
STELLUNG	POSIZIONE	HK2B	HK4B	HK1M	HK5B	HK18M	HK6B	HK8M	HK7B	HK9M
	3	○		○					⊙	⊙
		○		○				●		
	2	○		○			⊙			
SOLLEVAMENTO						⊗				
HEBEN	1	○		○	○					
	0									
SENKEN	1		○	○	○					
ABBASSAMENTO						⊗				
	2		○	○			⊙			
			○	○				●		
	3		○	○					⊙	⊙

30-HUBWERK
MECCANISMO DI
SOLLEVAMENTO

- SCHÜTZ EINGESCHALTET
- ⊙ SCHÜTZ SCHALTET VERZÖGERT EIN
- SCHÜTZ SCHALTET BEIM ZURÜCKSCHALTEN VON ST. 3 AUF ST. 2 AUTOM. EIN+AUS
- ⊗ SCHÜTZ SCHALTET BEIM ZURÜCKSCHALTEN VON ST. 2 AUF ST. 1 AUTOM. EIN+AUS

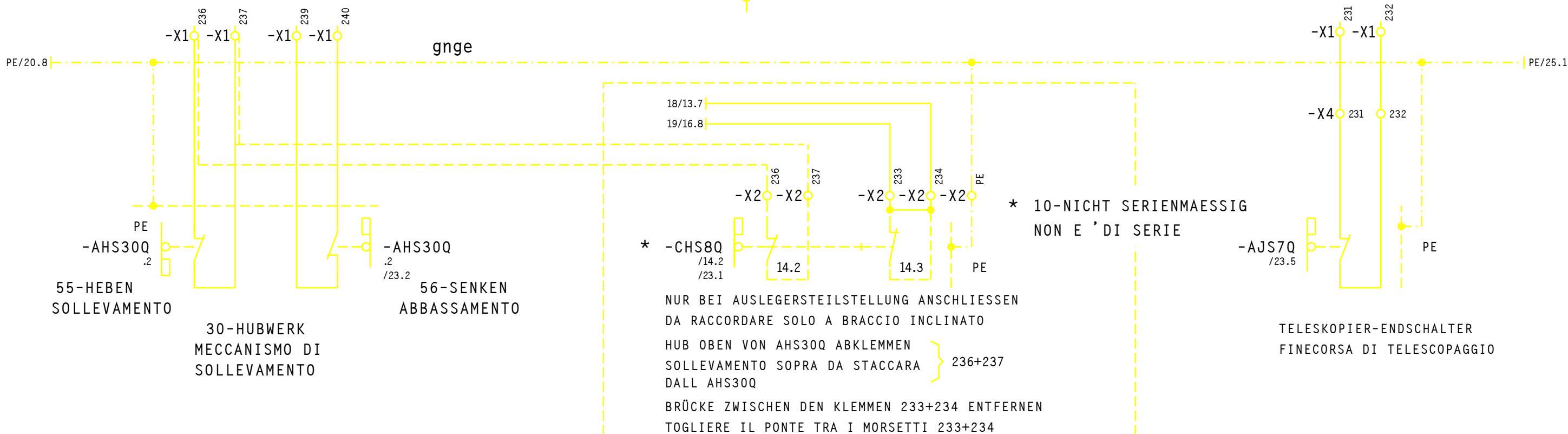

3			Gez.	31.08.09	HUBER		Maßstab	LIEBHERR-WERK	30-HUBWERK	TYPE	35K ITALIEN	=	S1
2			Bearb.				:	BIBERACH GmbH	MECCANISMO DI SOLLEVAMENTO	Zeich-Nr.	4005-21498	+	
1	Änderung	Datum	Name	Datum	Name			Copyright (c)				Blatt	21+
												Ident Nr.	611168501

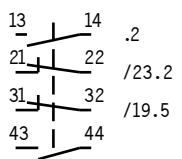
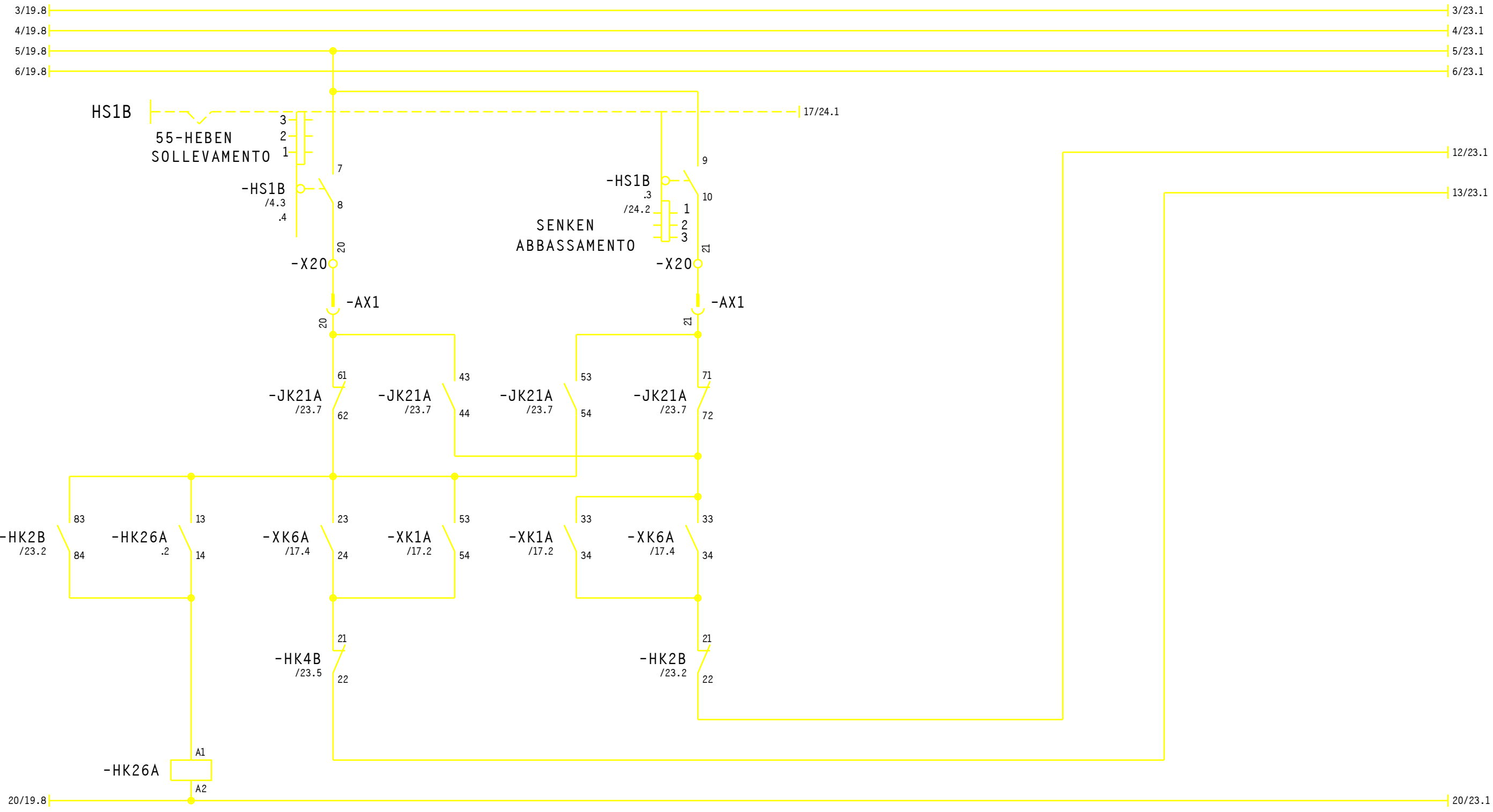

3			Gez.	31.08.09	HUBER		Maßstab	LIEBHERR-WERK	30-HUBWERK	TYPE 35K ITALIEN	=	S1
2			Bearb.			:	BIBERACH GmbH					+
1	Änderung	Datum	Name	Datum	Name		Copyright (c)	MECCANISMO DI SOLLEVAMENTO	Zeich-Nr.	4005-21498	Blatt	22+
											Ident Nr.	611168501

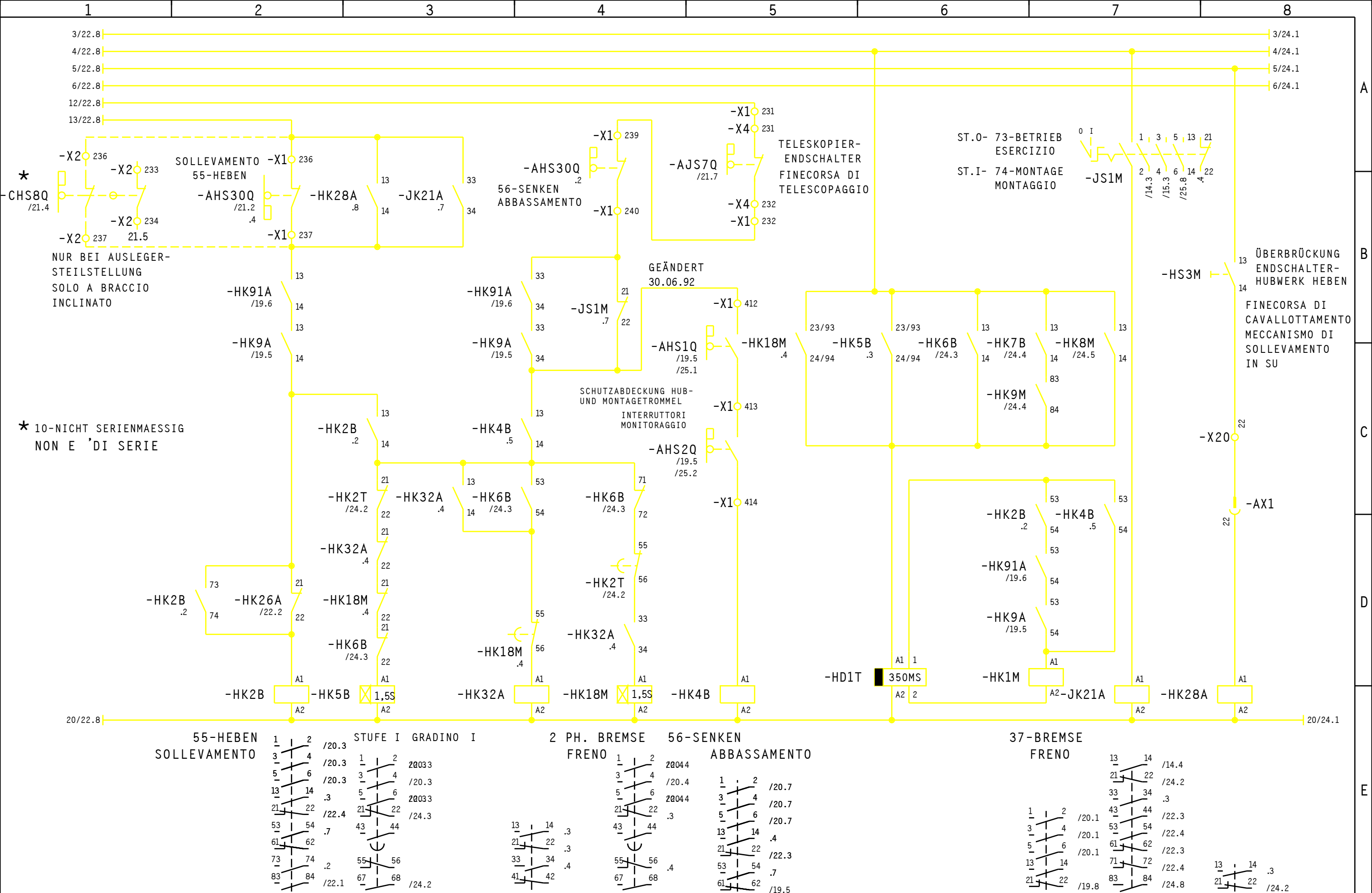

* 10-NICHT SERIENMAESSIG
NON E' DI SERIE

3			Gez.	31.08.09	HUBER		Maßstab	LIEBHERR-WERK	30-HUBWERK	TYPE	35K ITALIEN	=	S1
2			Bearb.				:	BIBERACH GmbH	MECCANISMO DI SOLLEVAMENTO	Zeich-Nr.	4005-21498	+	
1	Änderung	Datum	Name	Datum	Name		Copyright (c)					Blatt	23+
												Ident Nr.	611168501

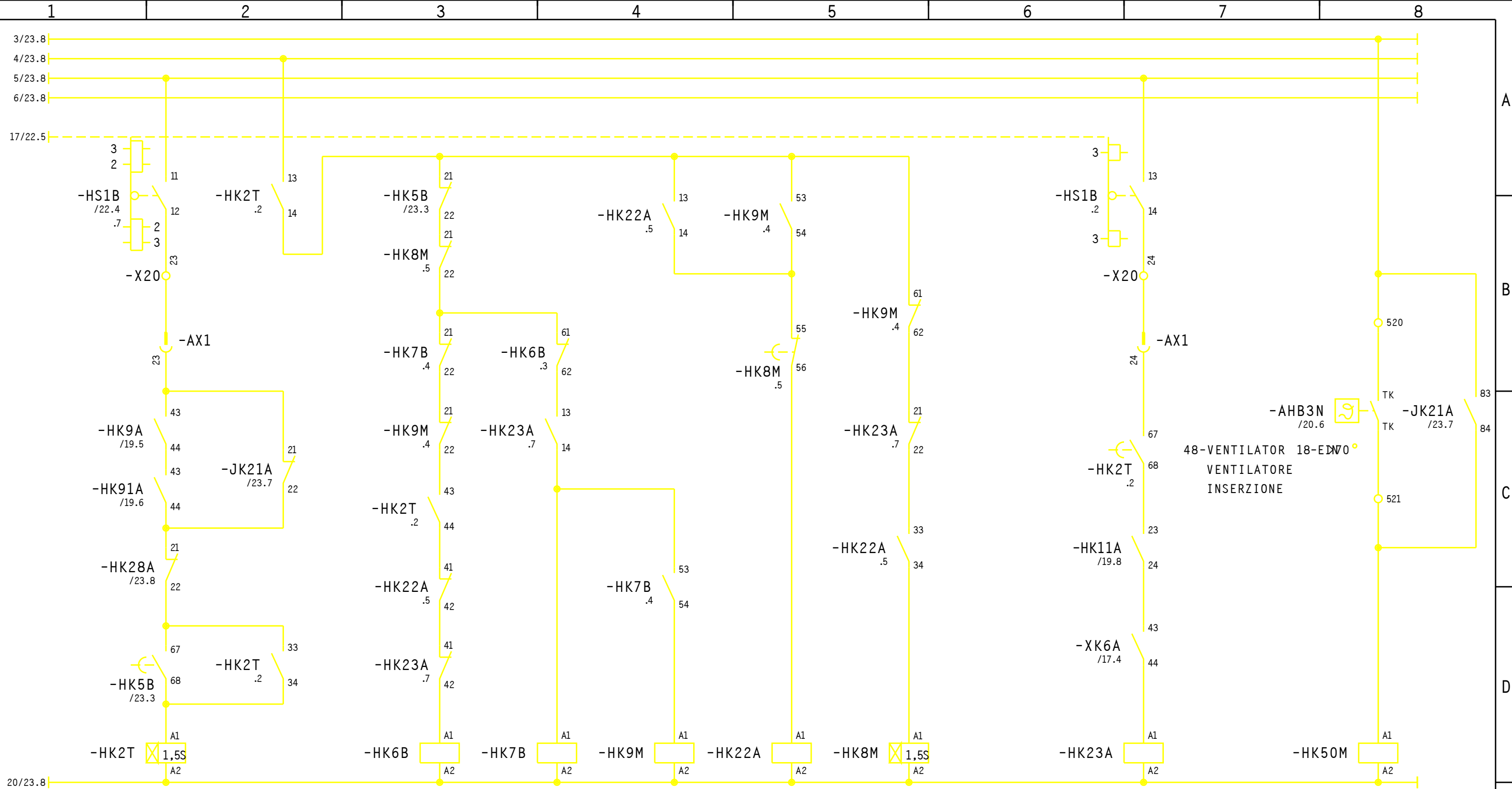

51-STUFEII GRADINO II 51-STUFEIII GRADINO III 51-STUFEIII GRADINO III 2 PH.BREMSE FRENO

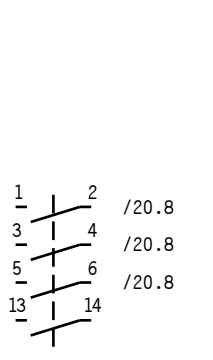
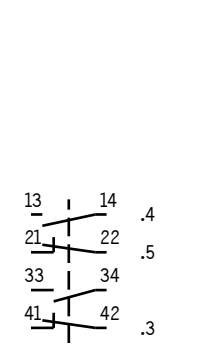
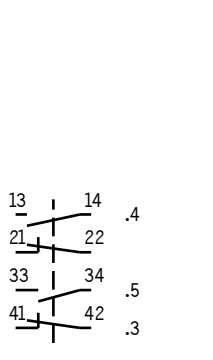
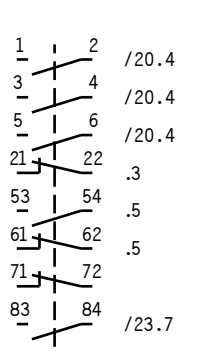
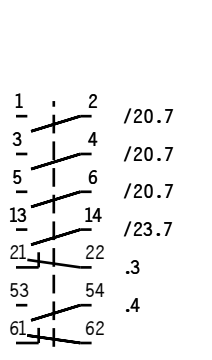
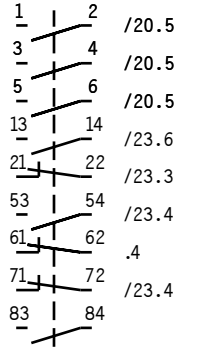
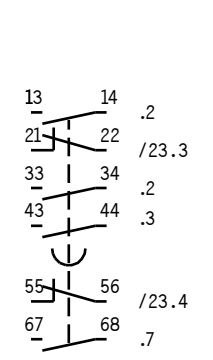

3			Gez.	31.08.09	HUBER		Maßstab	LIEBHERR-WERK	30-HUBWERK	TYPE	35K ITALIEN	=	S1
2			Bearb.				:	BIBERACH GmbH	MECCANISMO DI SOLLEVAMENTO	Zeich-Nr.	4005-21498	+	
1	Änderung	Datum	Name	Datum	Name		Copyright (c)					Blatt	24+
												Ident Nr.	611168501

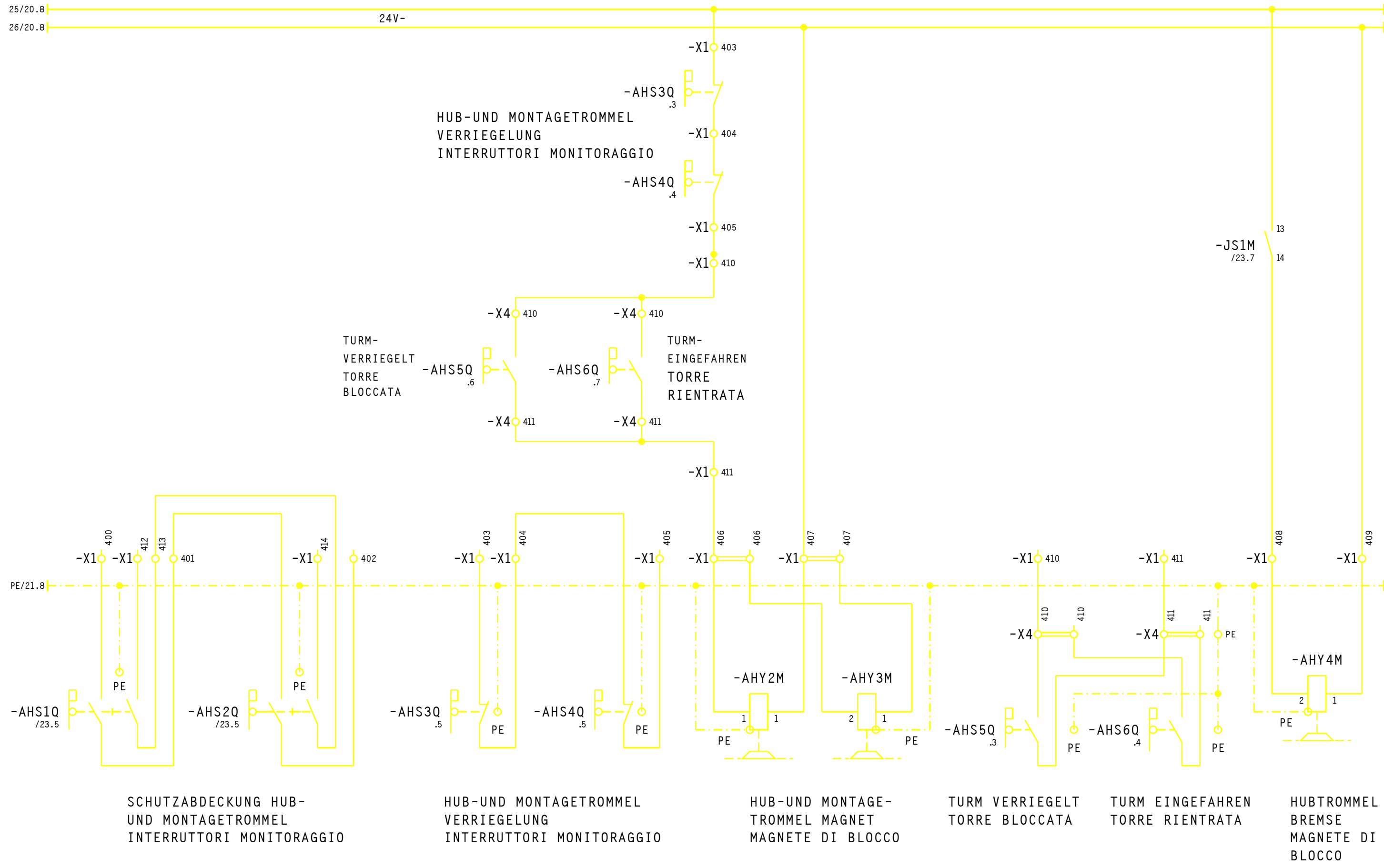

3			Gez.	31.08.09	HUBER		Maßstab	LIEBHERR-WERK	SICHERHEITSEINRICHTUNG ATTREZZATURA DI SICUREZZA	TYPE	35K ITALIEN	=	S1	
2			Bearb.			:	BIBERACH GmbH	Zeich-Nr.		4005-21498	+		Blatt	25 +
1	Änderung	Datum	Name	Datum	Name		Copyright (c)				Ident Nr.	611168501		

I= 29-KATZFAHRWERK
MECCANISMO DI
TRASLAZIONE CARRELLO
II= HILFSHUBWERK
MECCANISMO DI SOL.
AUSILIARIO CARICATO

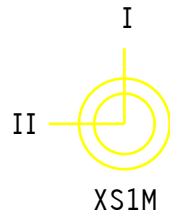

ÜBERBRÜCKUNG ENDSCHALTER-
HUBWERK HEBEN
FINECURSA DI CAVALLOTTAMENTO
MECCANISMO DI SOLLEVAMENTO
IN SU



13-HORN
AVVISATORE ACUSTICO

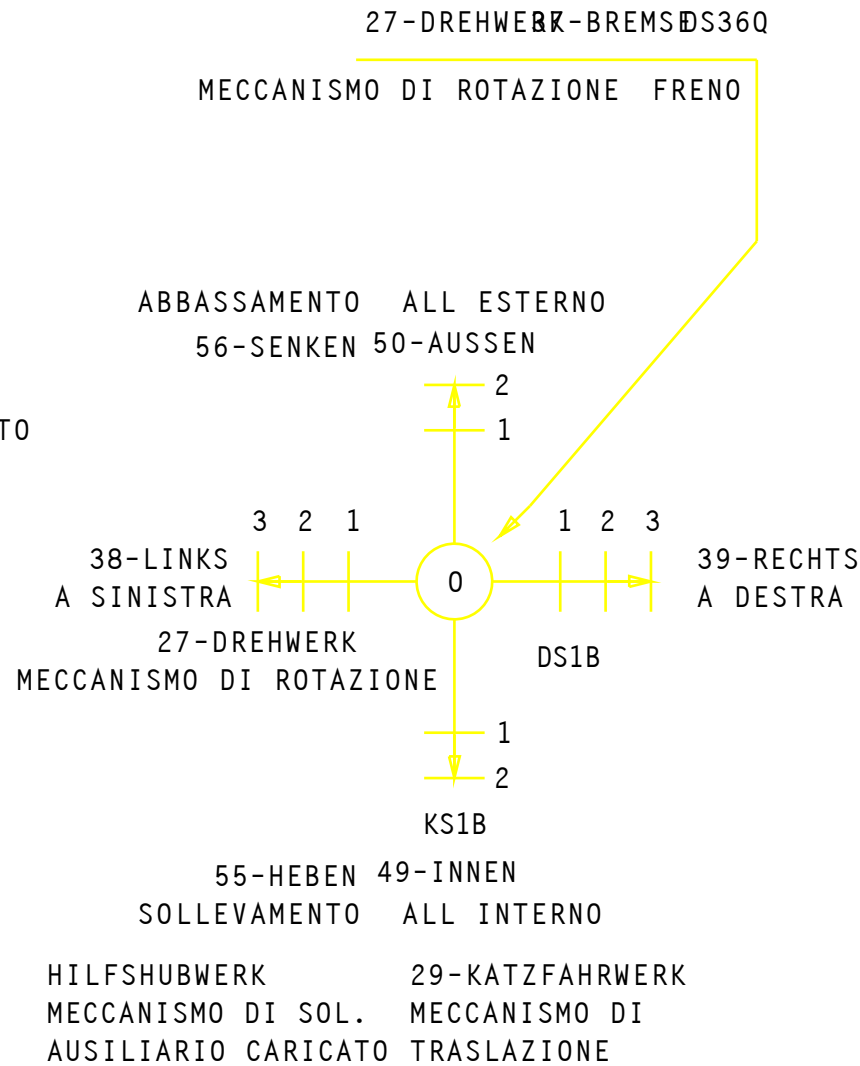

SISTEMA DI COMANDO INSERZIONE
16-STEUERUNG 18-EIN



SISTEMA DI COMANDO DISINSERZIONE
16-STEUERUNG 19-AUS



ARRESTO DI EMERGENZA
17-NOT-HALT

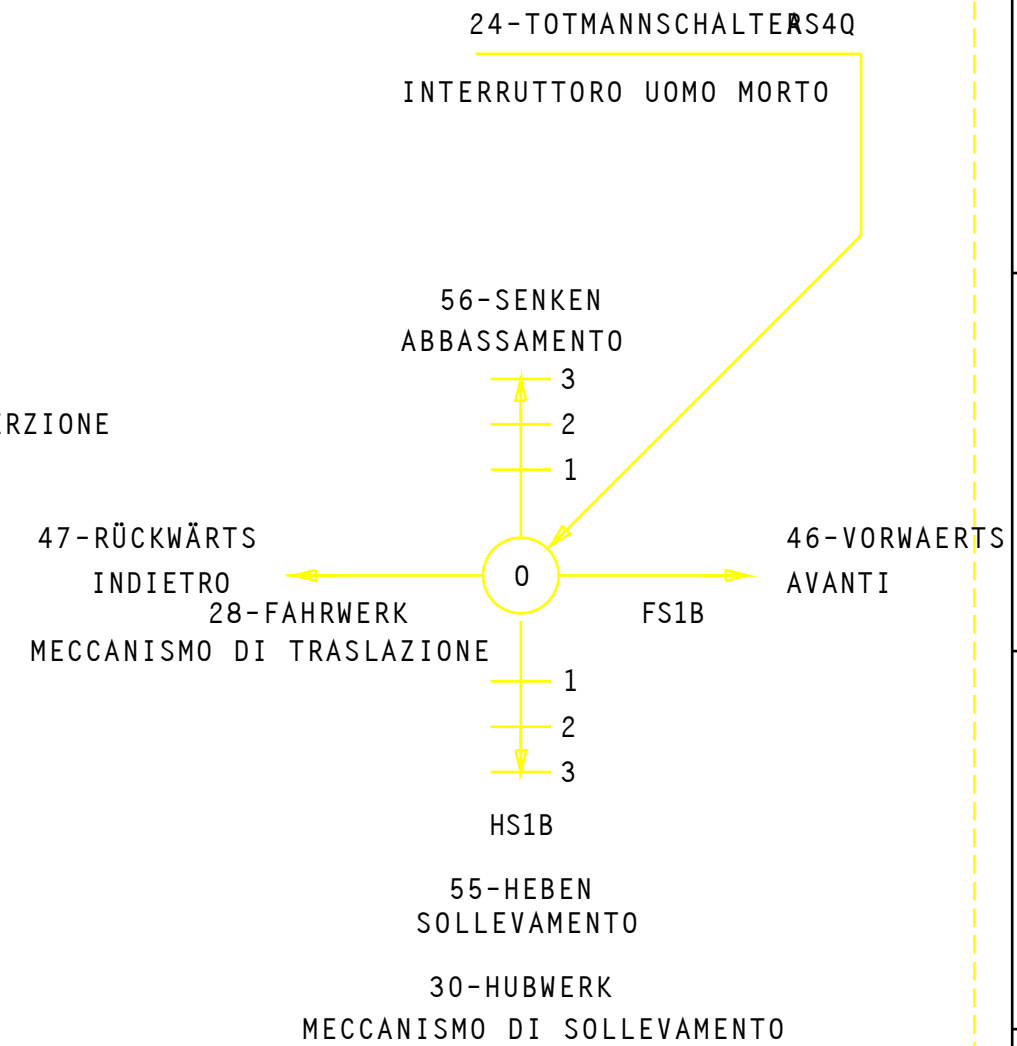

3			Gez.	31.08.09	HUBER		Maßstab	LIEBHERR-WERK	EINTEILIGES STEUERPUHT	TYPE	35K ITALIEN	=	S1
2			Bearb.				:	BIBERACH GmbH	BANCO DI COMANDO IN UN PEZZO	Zeich-Nr.	4005-21498	+	
1	Änderung	Datum	Name	Datum	Name			Copyright (c)				Blatt	26+
												Ident Nr.	611168501

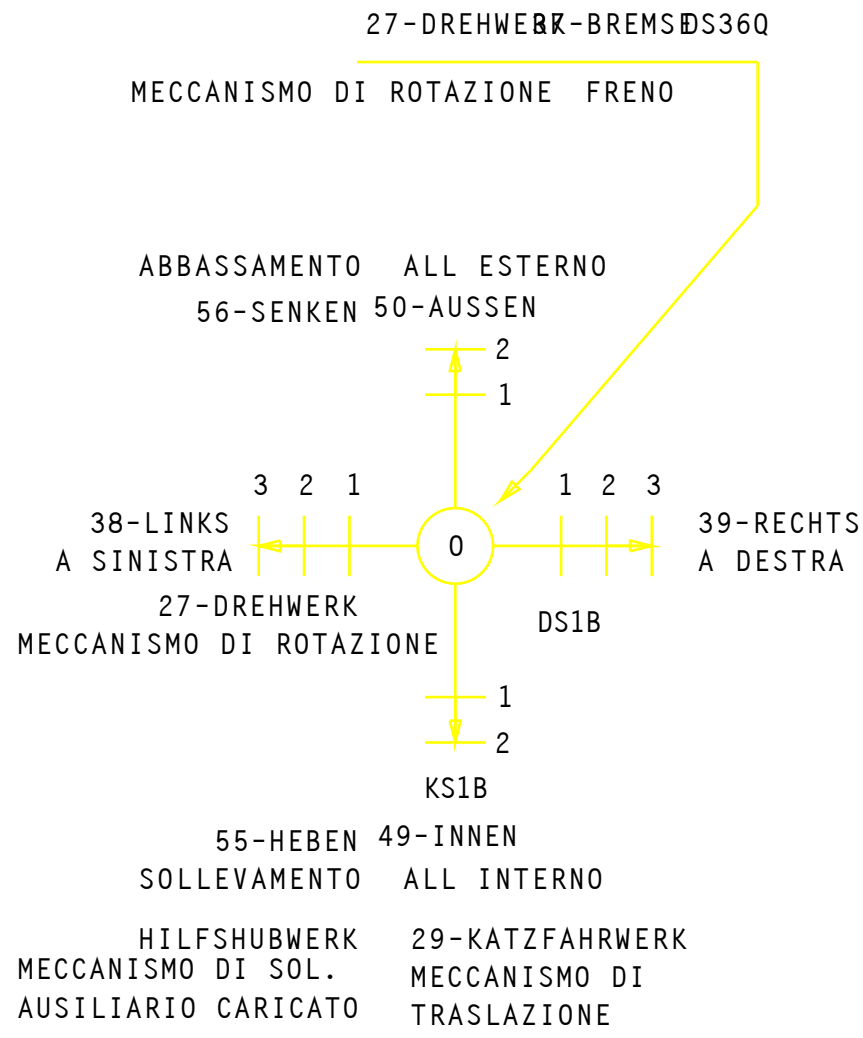

VERBINDUNGSKLEMMEN SIEHE SCHALTPLAN-SP.+ BURKHARDT ZEICHN.NR.CSO 347 (LBC 612531801)

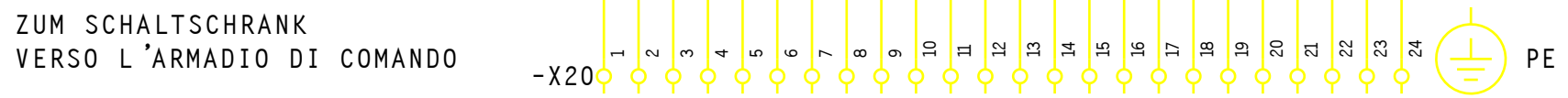
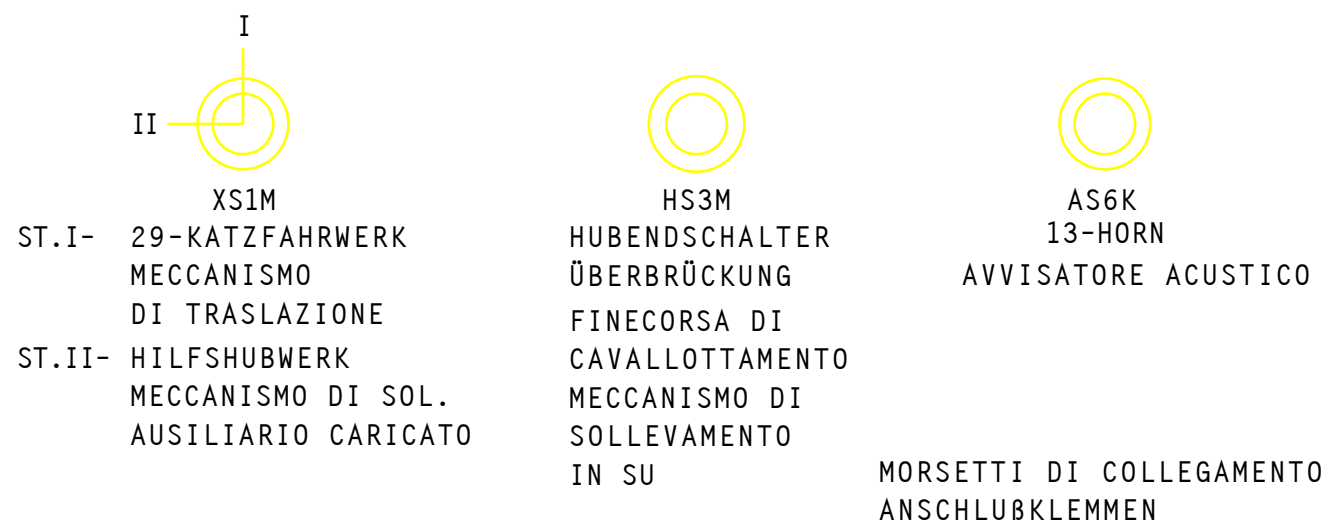
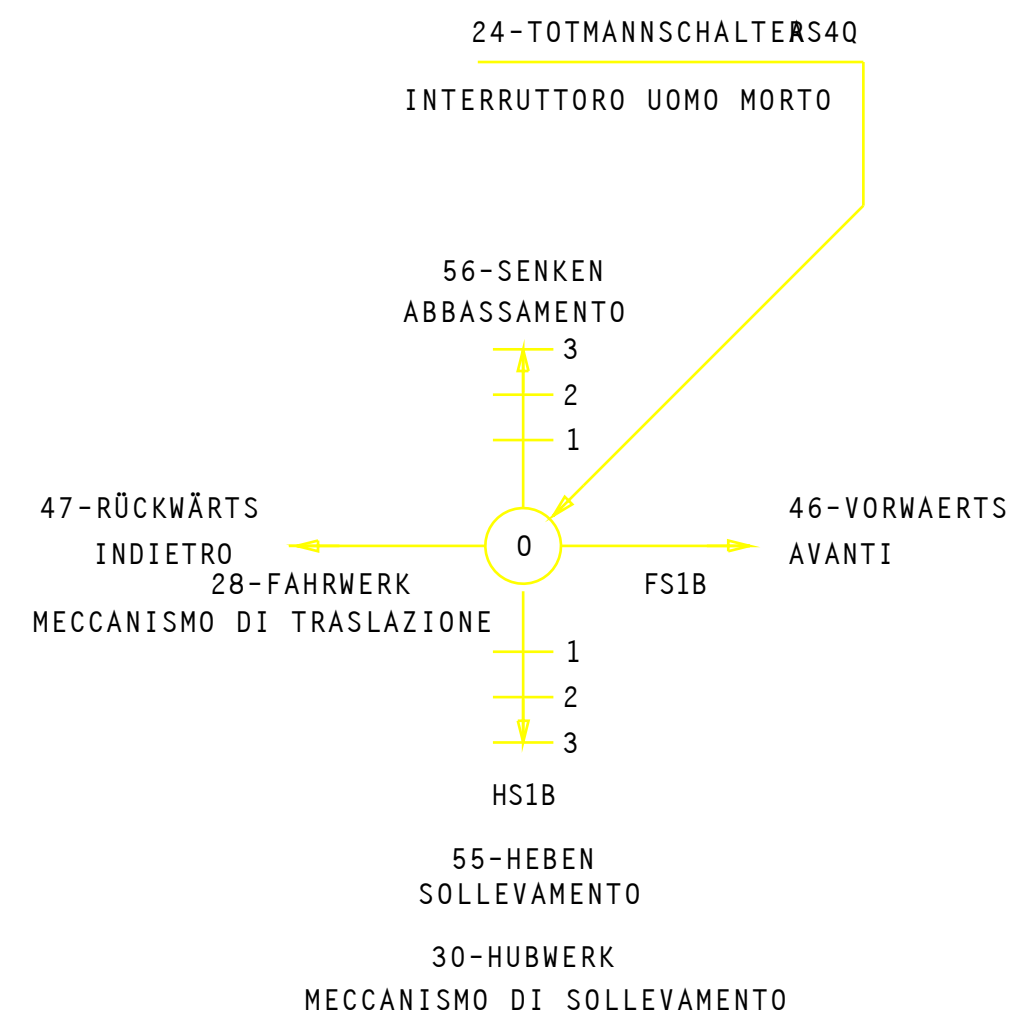

3			Gez.	31.08.09	HUBER		Maßstab	LIEBHERR-WERK	ZWEITEILIGES STEUERPU LT	TYPE	35K ITALIEN	=	S1
2			Bearb.				:	BIBERACH GmbH	BANCO DI COMANDO DIVISO	Zeich-Nr.	4005-21498	+	
1	Änderung	Datum	Name	Datum	Name			Copyright (c)				Blatt	27+
												Ident Nr.	611168501

5-STECKVORRICHTUNG
CONNETTORE A SPINE

14-SCHALTSCHRANK
VERSO I 'ARMADIO DI
COMANDO

VEDUTA DAL LATO CAVO
ANSICHT ANSCHLUBSEITE

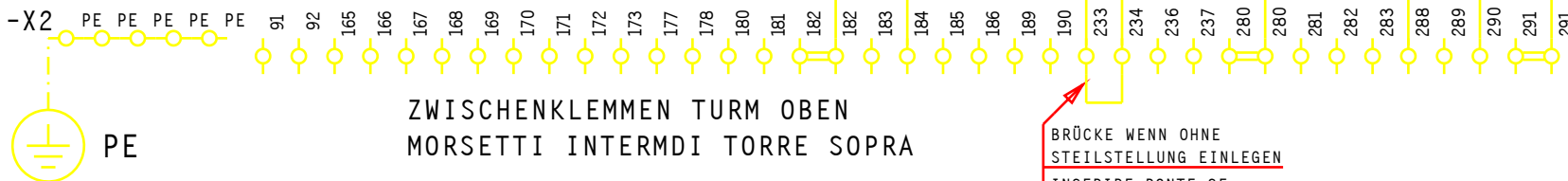

ZWISCHENKLEMMEN TURM OBEN
MORSETTI INTERMDI TORRE SOPRA

BRÜCKE WENN OHNE
STEILSTELLUNG EINLEGEN
INSERIRE PONTE SE
NON C'È POSIZIONE
INCLINATA

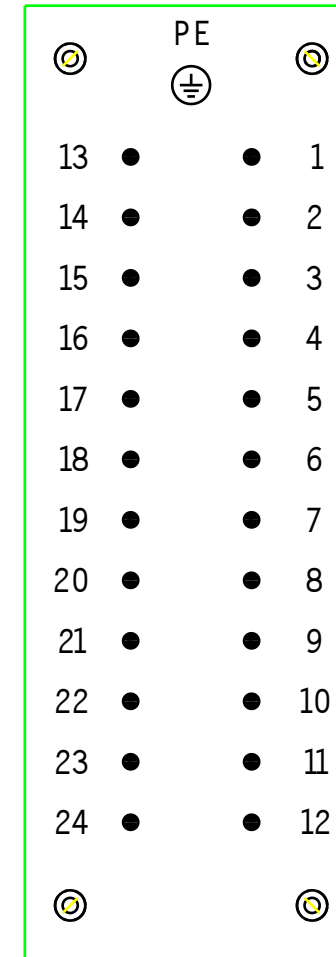

STIFTE
SPINE

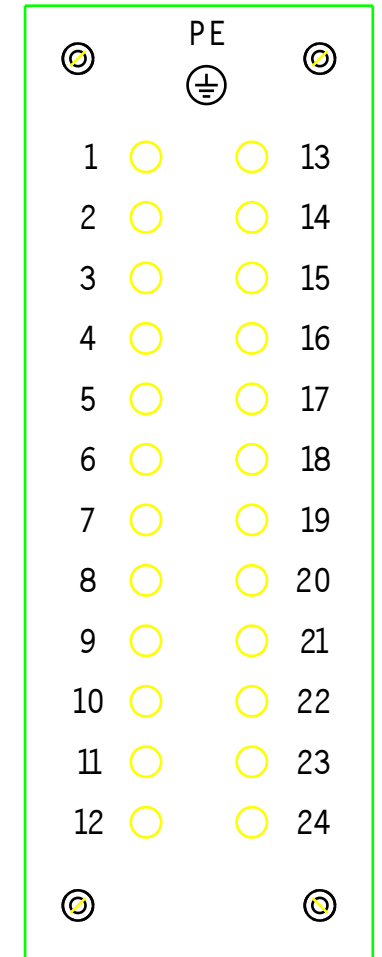

BUCHSEN
BUSSOLO

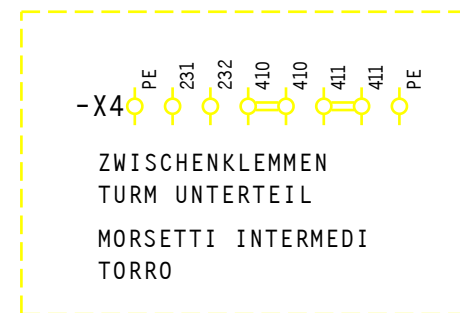

ZWISCHENKLEMMEN
TURM UNTERTEIL
MORSETTI INTERMEDI
TORRO

3			Gez.	31.08.09	HUBER		Maßstab	LIEBHERR-WERK	STECKDOSE FERNSTEUERKABEL	TYPE	35K ITALIEN	=	S1
2			Bearb.				:	BIBERACH GmbH	CONNETTORE AD INNESTO	Zeich-Nr.	4005-21498	+	
1	Änderung	Datum	Name	Datum	Name			Copyright (c)				Blatt	28 -
												Ident Nr.	611168501